

Astoria®
Think espresso

STORM

BARISTA ATTITUDE

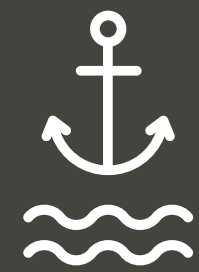



BARISTA
ATTITUDE

**“Mutable like a windy day,
scented with sea spray,
just like the burlap bags
in which coffee traveled
...”**

01

Sea

Everyday, for more than two centuries, coffee has been landing in the heart of Europe, in Trieste, a city suspended in time and space, a natural hub between East and West, a meeting point of intercontinental maritime routes and the Adriatic-Baltic and Mediterranean corridors. Trieste boasts a history of landings and trades permitted by its free port status awarded to it back in the eighteenth century. Trieste is coffee culture. Trieste is a multitude of daily rites and myths. Inspiration, style and love for anything good start here.



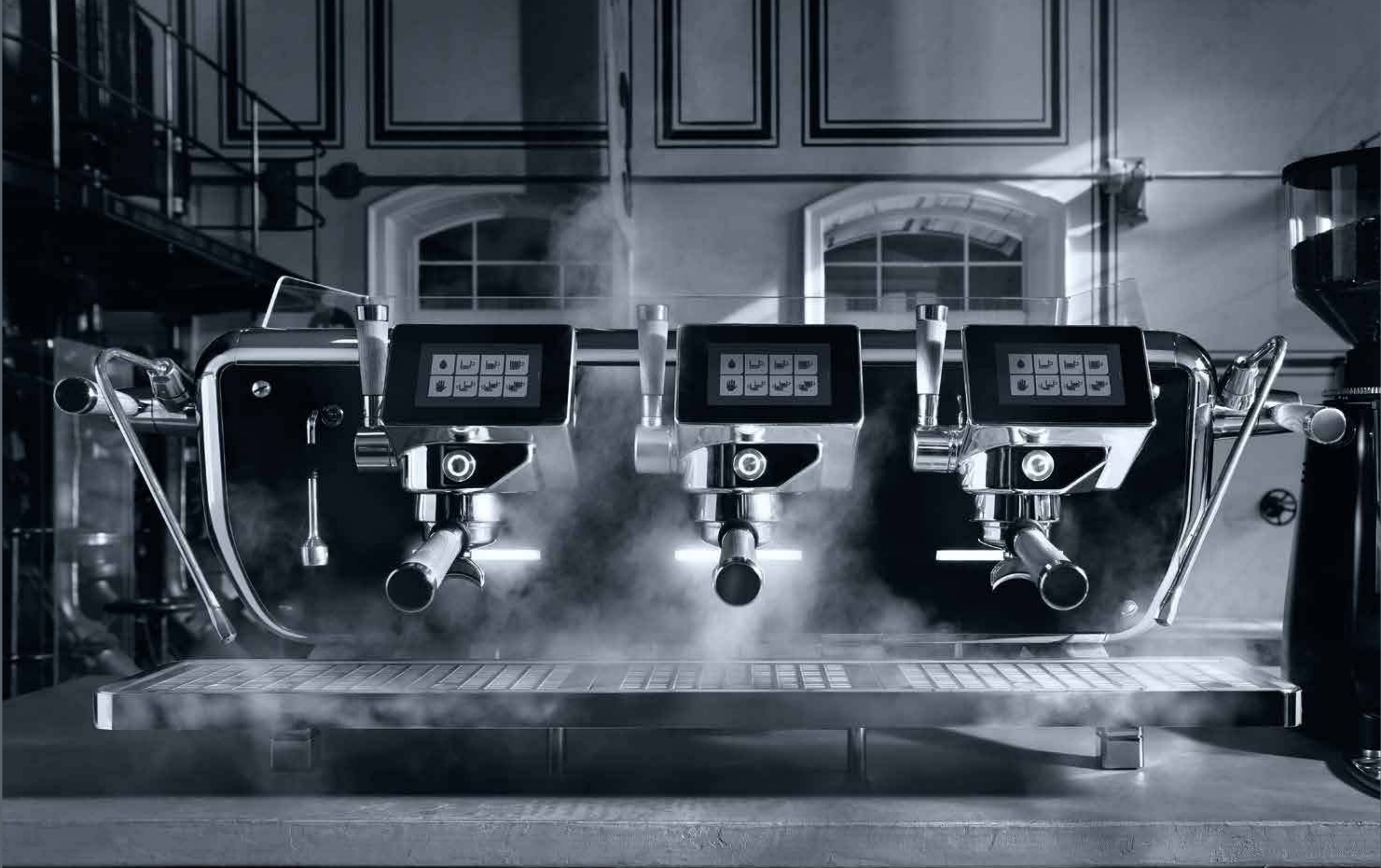

Sea

Storm



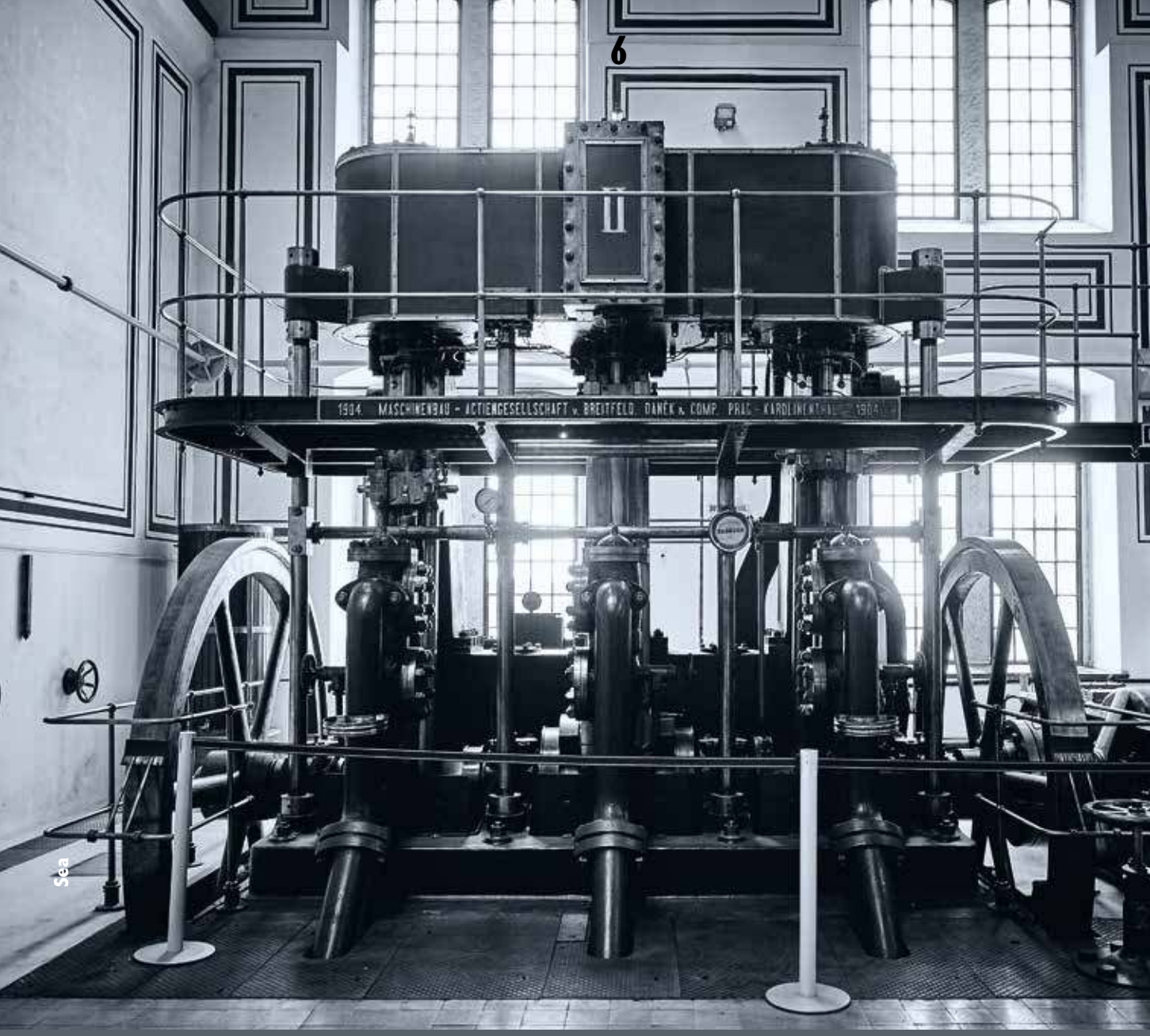

The Old Port of Trieste, built in the second half of the nineteenth century is a splendid specimen of industrial and commerce archeology. It bears witness to a city indebted to its Habsburg past, yet culturally projected towards the future, and endows the major shipping companies with oceanic routes to and from China, India and the rest of the Far East.





02

Style

High quality coffees, special coffees and traceable coffees whose history is known up to the last detail. And all of them are enhanced by total monitoring during the brewing process.

“
When coffee starts crackling and smoking, the roaster must be shaken, and beans removed as soon as they turn chestnut-brown, just prior to begin releasing oil
 ”

” Pellegrino Artusi

It is layered knowledge over time that transforms into energy and aroma the red drupes yielded by the bare Ethiopian plateau. Each berry encapsulates the multiform and elusive soul of regions where plants grow: Brazil, Vietnam, Colombia, Indonesia, Mexico, Guatemala, Honduras, Nicaragua, El Salvador, India, Ecuador ... Errant beans that man knows how to conquer, capturing its identity, grace and strength, in a game that swings between chemistry and art, between aesthetics and creative genius and between culture and lifestyle.



The Storm coffee machine is search of values that were believed to have been lost to passing time, but were brought back to life thanks to a new cultural and craftsmanship approach that, in a short while, has propagated across the world.

Delivered coffee is at the center of every concern. The baristas' gestures are the protagonist of the scene and have highly symbolic value. The relationship between who operates the coffee machine and who enjoys a cup of coffee is revolutionized: the barista who, with almost maniacal dedication, has chosen the grains, as well as the roasting and brewing steps can offer rituals of preparation and narration. Indeed, the Storm model is an easy to recognize machine with strong personality, raised on its feet but among the lowest in the category and to be placed on the counter to engender a front-line bartender-client relationship.



“The most challenging aspect of Latte Art is to create a precise model that is the fruit of imagination. I love to design, and, therefore, being able to shape my creativity thanks to Storm’s performance is great! Being able to leverage the quality of its dry steam is fundamental for great results!”

Aussie Caleb Cha, nicknamed Tiger, won the 2015 Latte Art World Championships in Gothenburg, Sweden, supported by Melbourne’s Cafenatics, his place of employment. Caleb impressed the judges with his intricate colorful butterfly design, followed by two models, the Flirting Peacock and the Caffeinated Zebra, completely new shapes compared to the usual swans, tulips and roses.

“I continue to train intensely, replicating the designs I have in mind hundreds of times, checking the time it takes for each step, as well as cup size and milk foam....”

Caleb Cha
Australia



The Storm features Super Dry, innovative technology that keeps steam “dry” by means of two heating spouts. The advanced system guarantees performance stability, even for prolonged periods of time, without any yield loss.





“The Storm coffee machine allows customizing the brewing process optimally, thanks to the pre-infusion control, pressure and temperature ... the most that can be asked of a machine!”



16



Michalis Dimitrakopoulos is a barista at “The Underdog” in Athens, a facility owned by Tasos Delichristos, the 2008 Coffee In Good Spirits Champion, who introduced Michalis to the world of Specialty Coffee. In 2016, Michalis became before the Greek Champion of Coffee In Good Spirits, and then the World Champion at the Shanghai Hotelex.

“When I feel the scent of coffee for me is the beginning of a game: every time, it is as if I have to discover the real feelings it sends me, so that I can convey them to customers... Every coffee can get better if it is paired with the right kind of spirit. My work is a continuous experiment to find the right balance among all ingredients.”



The Storm coffee machine allows maximum temperature control and water thrust force during coffee making. The barista can set parameters manually or use the digital functions.

Michalis Dimitrakopoulos
Greece

Arnon Thitiprasert
Thailand

Arnon Thitiprasert began working as a barista in Sydney in 2007, after leaving his hometown in southern Thailand. In 2017, he was crowned the World Champion of the Latte Art World Championships held in Budapest. He is the founder of Ristr8to, Ristr8to Lab and Doppio Ristr8to in Chiang Mai, Thailand.

“Since I started working as a barista, I have been committed to finding new designs, each single day. This is the fun part! I’ve traveled to more than thirty countries to explore coffee culture in the world: a barista should be familiar with the entire coffee production process. A very low machine allows getting in touch - immediately - with whoever is tasting my coffee!”

“My ideal machine must ensure maximum ergonomics: the Storm model allows me to move smoothly, have the right spaces and have direct visual contact with my guests”



Regardless of the counter space, the Storm machine allows using the 180° rotating steam wand. By adjusting the basin, baristas can keep the cup at the most appropriate level.





Enhanced by wood accents which can be personalized with different wood types and stains, the Storm coffee machine arouses emotions and was built in tune with the most technologically accurate studies. It is a competition machine that guarantees total control of the manual dispensing of mono-origin coffee and, at the same time, is suitable for use according to memorized brewing curves, which can enhance perfume and aromatic notes constantly.

Storm



“

**Coffee is a trip
into erudition**

”

A top quality coffee is not just a coffee without defects; it is a cup of coffee that brings out its inherent distinctive personality. It is the ability to choose the plantation and the particular botanical variety in a specific place in the world. It is utmost attention dedicated to the harvesting and processing of each grain. It is the challenge of fresh and expert roasting that can develop the coffee's full aromatic potential. It is the ability, on the bartender's part, to decide on the right coffee/water ratio, grain size, ideal water, temperature and contact time... It is a coffee that has to be told because it is always a result of an immersive experience.





**“For baristas,
the machine ergonomics
are never
just a detail.”**

03

Design

The Storm coffee machine is a mix of craftsmanship and cutting-edge technology. With it, a barista is free to express himself/herself and his/her own experimentation skills through simple and comfortable actions. Storm has taken into account the barista's movement requirements and his/her need to operate the levers to adjust coffee according to targeted taste and conception. The analog functions that enhance the customized brewing curves are also accompanied by digital storage functions of settings. Storm's refined design is the result of a cooperation that Astoria has

maintained for years with Adriano Design, a Turin based studio, which is one of the most important and renowned design studios in Italy, honored with the most prestigious national and international prizes such as the Compasso d'Oro international award.

The fully innovative suspended basin features a formal tray which supports the cup during brewing. Indeed, the cup is no longer hidden from the machine, but rests on a plate, as if it were a prima donna on stage. This design also produces practical effects because the basin, with its rounded lines, is easy to clean.







A The side/rear panel is mechanically connected by screws embedded in the frame; the removal of side panels is simplified, which makes access to the Storm's internal parts easier. The electronic control unit can be accessed by removing the left panel. The tilting compartment allows accessing the electrical and electronic components of the power supply system directly from the heater cover front panel, without any need to remove parts from the rear.



B The Barista Attitude anti-scald and cantilevered steam wand offers great safety and easy return movement to the basin, in case of inactivity. Super Dry is the innovative system that keeps the steam dry and with minimum initial condensation, guaranteed by a solenoid valve placed in the discharge. A reduced quantity of humid steam is discharged at 110°C in order to guarantee the presence of dry steam ready for use. The new Super Dry system guarantees continuous steam use without decreasing performance, even when two steam wands are used simultaneously.



C The Storm's filter holders are made of treated oak wood. Ergonomics and balance make it the perfect companion of every barista.

D In Storm, the basin adjustment lets the barista keep the cup at the best level for the beverage being made. Routine cleaning operations are also more fluid and uniform thanks to the rounded shape, whereas washing is facilitated by the vertical extraction of the basin.

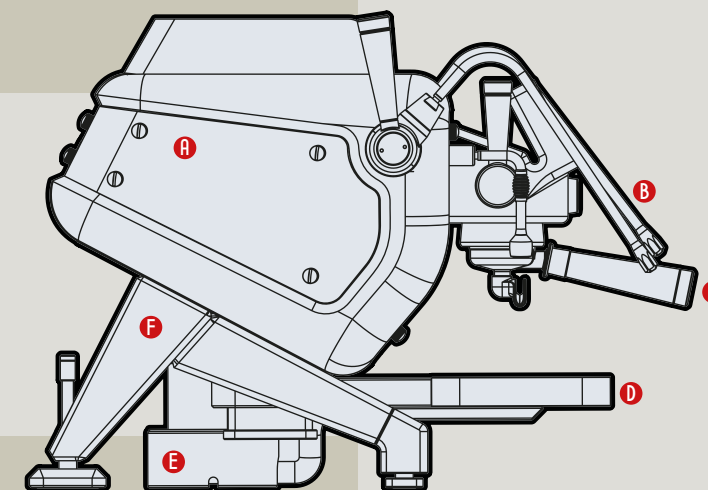

E The loading and unloading hoses and feed inputs are connected within a cylindrical structure that makes the visible part of the machine more elegant and neat. As a result, cables and hoses are directly connected to the hole on the counter, avoiding the exposure of cables typical of raised machines. The structure also includes two lateral holes for the passage and insertion of the grinders' power feed.

F Storm rests on treated oak wood supports that ensure durability and cleanliness. The feet are made of polished stainless steel, and fitted with single (10mm) front and rear adjustment to ensure that Storm perfectly rests on the counter.



G In the FRC version, the brewing curve is handled through a manual drive paddle placed next to the group, controlled by the barista.

All brewing peculiarities are at the barista's discretion; Storm allows customizing each cup according to his/her needs.

It is possible to set the display curve by relying on five parameters; changing one or more parameters can change the organoleptic features of the coffee being prepared. The brewing curve can be independently programmed, both between groups and with each cup.

1. Quantity of water in pre-infusion: by entering a value from 1 to 6, a different amount of water will be released during pre-infusion.

2. Pre-infusion time: the pre-infusion time can be set from 0 to 20 seconds, thereby also defining the extraction speed.

3. Value that changes the brewing curve: the higher the value, the higher the delivery rate.

4. Amounts in milliliters with which the pressure can be changed during coffee making, reaching the minimum value to ensure a perfect cup of coffee.

5. The extraction rate changes during brewing until reaching the minimum value to ensure a perfect cup of coffee; the higher the value, the quicker the drop.

Green Line: low environmental impact, reduces consumption up to 47.6%* compared to traditional coffee machines. Thanks to innovative software that manages the standby automatic system during breaks, night-time energy-saving function and intelligent temperature regulation, Storm distributes power only where and when needed. In addition, Storm automatically puts one or more groups into standby mode when the workload decreases, reverting to full-time mode as warranted by circumstances.

* Datum certified by Intertek - ETL SEMKO, an independent body dealing with safety testing and product certification.



H The group cover houses a 5" display and an electromechanical competition key that, once positioned exactly above the filter holder, allows its coupling and manual start-up in a single movement.

By acting on the hidden screw, it is easy to remove the crankcase for maintenance work on it and on the display.

J To make Storm usable under any light condition and ensure that coffee is optimally viewed inside the cup, the work counter features LED lights, whose intensity can be adjusted from the display directly by the user.

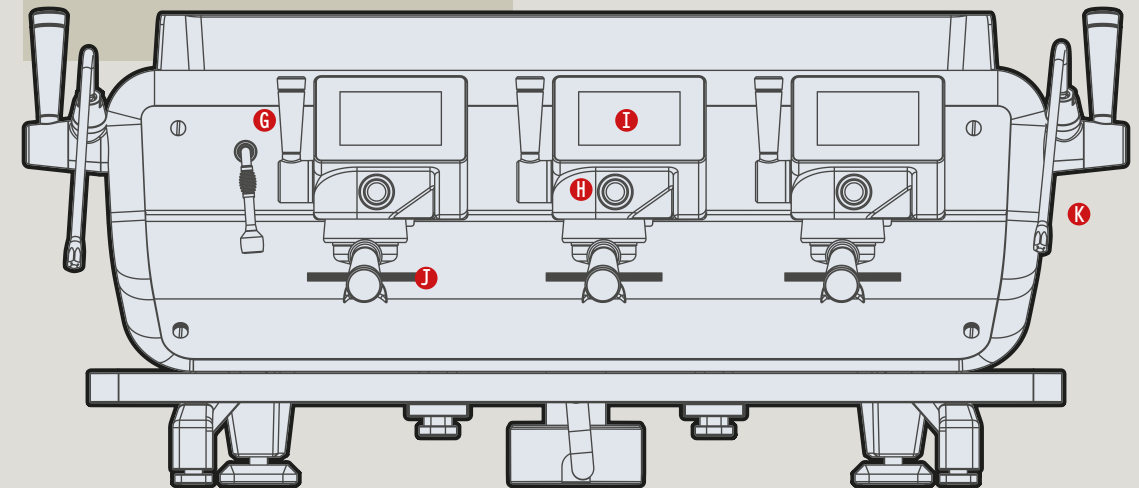

I Storm is equipped with a capacitive 5" display per group, with which it is possible to:

- Program the brewing curves for each group
- Set the dispensing temperature for each group
- Display the graph of the last coffees prepared
- Set the power saving mode
- Program doses
- Display counters
- Wash group
- Change hot water temperature
- Connect to the Cloud Server

K Storm is equipped with the SB (Steam Boost) option, which can be activated by the technician during installation or is available in the Extreme Steam Boost version, which can maximize the efficiency of steam production, as needed.

SB increases steam production by activating the heating units even during high-volume espresso making (alternating power between service and coffee heating units).

In the ESB version, however, steam production is maximum, all heating units on Storm can be activated at the same time, minimizing the recovery time of the machine (maximum absorbed power for 2GR 5800/6315 W/h and 3GR 7333/7985 W/h).

Technical product sheet

		2 gr	3gr
Voltage	V	230/240-400/415	230/240-400/415
Maximum absorbed power	W	4800/5230	6400/6970
Maximum absorbed power (ESB version)	W	5800/6315	7333/7985
Power per group	W	150x2/165x2	150x3/165x3
Coffee water tank resistor power per group	W	1000x2/1090x2	1000x3/1090x3
Steam heating unit power	W	3000/3270	4000/4360
Steam heating unit load capacity	Lt/ UK gal	8.5/1.87	8.5/1.87
Coffee water tank load capacity	Lt/ UK gal	(1.2/0.26)x2	(1.2/0.26)x3
Weight	Kg/lb	85/187	105/ 231
Width	mm/in	1035/40.7	1175/46.2
Depth	mm/in	618/24.3	618/24.3
Height	mm/in	500/19.7	500/19.7



Serial features

- Electronic cup warmer
- LED-lit work counter
- LED backlight with light-intensity change
- Energy Saver: automatic On/Off and Standby
- Mode of use: comfort (machine always active), weekly programming (programming of time slots for standby), Eco (self-learning based on machine operation)
- Views: time, brewing temperature, brewing chart, brewing pressure (on FRC version, for each group)
- Machine parameters export
- Counts: number of coffee and hot water delivered, liters of water consumed, warning regeneration filters, grinder wear and tear, number of washings performed
- Digital boiler pressure display and control
- Digital delivery pressure display
- USB port
- User interface: a display for each group; choice of skin type.
- Maintenance: servicing for scheduled maintenance
- Languages (Italian, English, German, French, Spanish, Portuguese, Chinese and Russian)
- Customizable screensaver
- Dose programming
- Coffee recipes: possibility of parameter settings for different types of coffee
- Basin and feet height adjustable
- Barista Attitude: anti-scalding steam wand
- Super Dry: dry steam dispensing system
- Steam Boost (SB): activated by the technician, depending on the operating needs of the machine
- FRC version: brewing curve and customization
- Bluetooth
- Configuration of brewing curves for each key
- Hydraulic circuit efficiency control system

Optional

- Auto-steamer
- WiFi for telemetry
- ESB (Extreme Steam Boost)

Colors

-  Matt Black/Chrome
-  White/Chrome
-  Red/Chrome
-  Matt Black/Matt Black
-  Copper/Matt Black

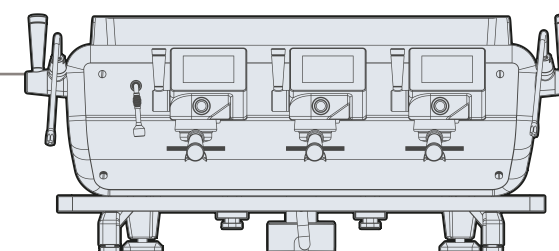

Storm FRC

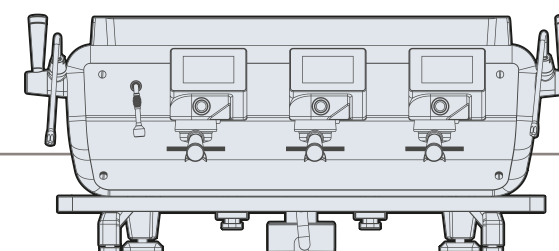

Storm MULTIBOILER



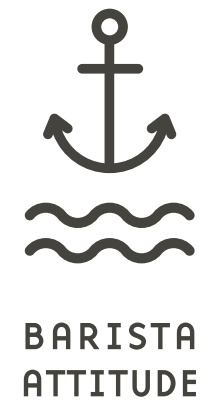



www.astoria.com



www.astoria.com