







FIANCHI ESTETICI:

Colori disponibili standard

SIDE PANELS:

Available standard colours

			
Grigio E_Z065	Blu Cielo RAL 5005	Bianco Segnale RAL 9003	Orange RAL 2001
			
Beige Perlato RAL 1035	Rosso RAL 3020	Lemon RAL 1032	Alluminio Brillante RAL 9006

VETRINA GELATO PROFESSIONALE A REFRIGERAZIONE VENTILATA

Vetrina gelato professionale canalizzabile a refrigerazione ventilata con doppio flusso d'aria per una perfetta equalizzazione della temperatura. Esposizione inferiore a refrigerazione ventilata con l'innovativo sistema di mandata dell'aria longitudinale che massimizza la capacità espositiva e la visibilità del prodotto. Sia l'esposizione superiore che quella inferiore sono dotate di set temperature $-20/+2$ °C, che permette di esporre a seconda dell'esigenza, pasticceria, semifreddi, torte gelato o gelato in vaschetta (solo per esposizione superiore). Struttura portante e basamento in acciaio al carbonio verniciato a polvere epossidica, con piedini regolabili. Scocca monolitica coibentata in poliuretano ecologico (HCFC & HFC free) espanso a CO2 con spessore mm 60. Piani espositivi, interno vasca, pannello lato operatore e piano di servizio in acciaio inox finitura lucida. Sovrastruttura con scimitarre frontali monolitiche in acciaio inox finitura lucida, spessore 10 mm. L'intero castello vetri è realizzato con doppi cristalli riscaldati. Profili in acciaio inox finitura lucida. Illuminazione elettronica a led. Per l'esposizione superiore apertura del vetro frontale verso l'alto servoassistita; per esposizione inferiore apertura verso il basso con sistema di bloccaggio di sicurezza. Chiusura lato operatore a scorrevoli rimovibili per l'esposizione superiore. Accessibilità al vano inferiore tramite cassetti con sistema di scorrimento telescopico. Ogni settore è dotato di un proprio quadro comandi e centralina elettronica posizionate su lato operatore. Entrambe le vasche sono dotate di sistema di sbrinamento automatico ad inversione di ciclo.

PROFESSIONAL GELATO CABINETS AT VENTILATED REFRIGERATION

Double display Gelato cabinet with Fan Ventilated refrigeration and double air flow for a better distribution of temperature. Lower display area with fan ventilated refrigeration with a new central air flow system for bigger display capacity and product visibility. Either the upper display area and the lower one can be set to temperature $-20/+2$ °C, which permits to display according to the needs, pastry, semifreddi, ice cream cakes, or ice cream in containers (only for upper display area). Main structure and basement in carbon steel epoxy powder painted with adjustable feet. Unique body with ecological polyurethane insulation (HCFC & HFC free), foamed with CO2- 60 mm thick. Display area, internal tank, rear panel, service top in bright stainless steel. Upper structure with monolithic stainless steel bright 10 mm thick structure positioned on the customer side. The whole glass structure in tempered heated double crystal glass. Profiles in bright stainless steel. Electronic lighting with led. Lift-up front glass with pistons for the upper display area. Tilting up front glass with security lock for the lower display area. Operator side closure with removable sliding lids for the upper display area. Telescopic sliding drawers for the lower display area. Each sections has its own control board and electronic board positioned on the operator side. Both tanks have intelligent defrosting system by reverse cycle.

ESCLUSO: - KIT VASCHETTE GELATO - VASSOI

NOT INCLUSIVE OF: - ICE-CREAM CONTAINERS KIT - TRAYS

INCLUSO: - FIANCHI LATERALI - ILLUMINAZIONE ELETTRONICA A LED - IMBALLO

INCLUSIVE OF: - SIDE PANELS - ELECTRONIC LIGHTING WITH LED - PACKAGING

H117

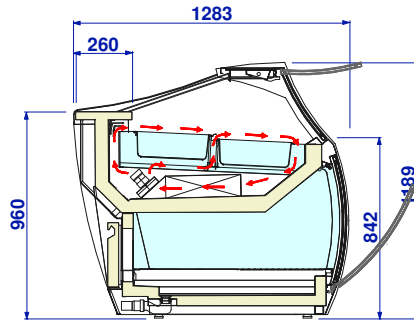

MODELLO MODEL	CODICE CODE
120	PGA0012000
170	PGA0017000
220	PGA0022000
AE 30	PGA00AE300
AI 30	PGA00AI300L
COM BI	
170	PGA0012500
220	PGA0017500

H135

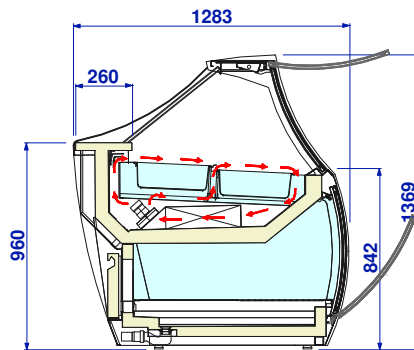

MODELLO MODEL	CODICE CODE
120	PGA0012000
170	PGA0017000
220	PGA0022000
AE 30	PGA00AE300
AI 30	PGA00AI300L
COM BI	
170	PGA0012500
220	PGA0017500

H150

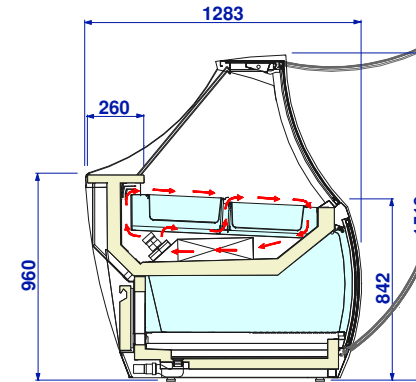

MODELLO MODEL	CODICE CODE
120	PGA0012000L
170	PGA0017000L
220	PGA0022000L
AE 30	PGA00AE300L
AI 30	PGA00AI300L
COM BI	
170	PGA0012500L
220	PGA0017500L

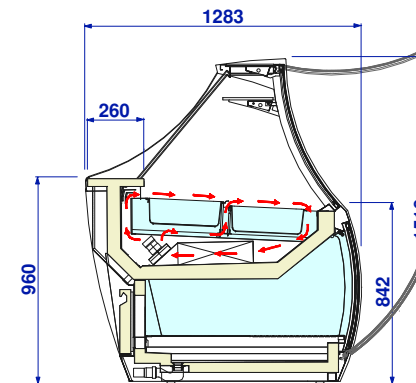

1M	
120	PGA0012000L
170	PGA0017000L
220	PGA0022000L
AE 30	PGA00AE300L
AI 30	PGA00AI300L
COM BI	
1M	
170	PGA0012500L
220	PGA0017500L

● OPTIONAL		Dimensioni (lpxh) Dimensions (lxdxh) (mm)	Modello Model	Codice Code	
● Portaconi completo finitura grigio	Grey cone holder			9001390900802	
● Portaconi completo di vaschette portagranelle	Cone holder complete of toppings container			9001390900801	
● Consolle lavaporzionatore con rubinetto	Consolle scoop washer with water tap		120, 170, 220. AI 30	9001920000006	
			AE 30	9001920000008	
● Consolle lavaporzionatore con doccetta avvolgitubo	Consolle scoop washer with shower selfrolling		120, 170, 220. AI 30	9001920000007	
			AE 30	9001920000009	
● Vassoio inox (2 vaschette lt 5)	Stainless Steel tray (2 containers lt 5)	330x360x40H	120, 170, 220	9001920000015	
● Vassoio inox (2 vaschette lt 5)	Stainless Steel tray (2 containers lt 5)	330x360x100H	120, 170, 220	9001920000014	
● Vassoio inox (3 vaschette lt 5)	Stainless Steel tray (3 containers lt 5)	500x360x40H	120, 170, 220	9001920000012	
● Vassoio inox (3 vaschette lt 5)	Stainless Steel tray (3 containers lt 5)	500x360x100H	120, 170, 220	9001920000011	
● Vassoio inox	Stainless Steel tray	330x720	120, 170, 220	9001920000013	
		500x720	120, 170, 220	9001920000010	
● Kit vassoi inox	Stainless Steel tray kit		AE 30	9001920000018	
			40H	AE 30	9001920000019
			100H	AE 30	9001920000020
			100H	AI 30	9001920000023
				AI 30	9001920000021
			40H	AI 30	9001920000022
● Kit tubazioni per UCR - al metro lineare	Piping kit for Remote Condensing Unit - each meter			9006000000007	

