



ICE MACHINES MÁQUINAS DE HIELO

CATALOGUE | CATÁLOGO





Certifications obtained in several of our machines
Certificaciones obtenidas en varias de nuestras máquinas

CATALOGUE | CATÁLOGO **50 Hz**

A HUMANE AND HUMANIZING COMPANY

ABOVE ALL, PEOPLE

ITV-Ice Makers manufactures ice machines. Behind this apparently simple reality, people live and work, and this is what makes our daily activity such a complex and enriching task, full of responsibilities but also exciting challenges. ITV is intended to be a humane and humanizing company, projecting, inviting and integrating its customers and suppliers.

EVERYTHING IS CONNECTED

We all count in order to achieve the objectives of ITV. We do not conceive that the satisfaction of our customers can be separated from the satisfaction that we as the workers of this company feel, nor can there be a solution of continuity between the expectations of the final customers and the quality of the product.

WHAT SHOULD AN ITV CUSTOMER DEMAND?

A competitive, top-quality range of products and services, which enables them to market, quality and guaranteed machines, and to conduct their business with full satisfaction. Quality management and a high level of involvement from our entire organization.

Competent guidance and high quality service.
Clean and safe technologies within a line of sustainable development.

Orientation of levels of the company to the customer's: foreseeing present and future needs, anticipating market changes and adapting to their own technological and logistical transformations.

UNA COMPAÑÍA HUMANA Y HUMANIZADORA

POR ENCIMA DE TODO, PERSONAS

ITV-Ice Makers fabrica máquinas de hielo. Detrás de esta realidad viven y trabajan personas, y eso es lo que convierte nuestra actividad diaria en una tarea enriquecedora, repleta de responsabilidades pero también de retos apasionantes. ITV pretende ser una empresa humana y humanizadora, proyectando, invitando e integrando en ella, junto a sus trabajadores, a clientes, usuarios y proveedores.

TODO ESTÁ CONECTADO

Todos contamos para lograr los objetivos de ITV. No concebimos que se pueda separar la satisfacción de nuestros clientes de la que sentimos los trabajadores de esta empresa. Y hay continuidad entre las expectativas de los clientes finales y la calidad del producto.

¿QUÉ NOS EXIGEN LOS CLIENTES ?

La orientación de todos los estamentos de la empresa hacia las necesidades del cliente: prever sus expectativas presentes y futuras, anticiparse a los cambios en el mercado y adaptarse a sus propias transformaciones tecnológicas y logísticas, nos permite determinar las demandas que confían en nuestra empresa.

Una propuesta de productos y servicios competitiva y de alto nivel, que le permita disfrutar de máquinas de calidad y garantía, desarrollando su negocio satisfactoriamente. Calidad en la gestión y un elevado nivel de implicación de toda nuestra organización.

Asesoramiento competente y servicio de alta calidad. Tecnologías limpias y seguras dentro de una línea de desarrollo sostenible.



THE SEVEN VALUES OF ITV

THESE ARE THE WAYS OF THINKING AND ACTING THAT ALL OF US WHO WORK AT ITV HAVE OBLIGED OURSELVES TO INTERNALIZE, BY CONVICTION

1. Integrity and professional ethics in human and commercial relations, both internal and external.
2. Commitment to the environment and sustainable growth; which is compatible with the continuous improvement of products and processes, and of working conditions.
3. Headed by Management, the triple objective of the recognition of quality, the environment and safety at work is a responsibility shared by all levels of the organization.
4. Only respect for the ideas of others and transparency in all our actions allow for the recognition of errors, which is inherent to any learning process.
5. Success is based on a combination of many factors, such as profitability, efficiency, productivity, motivation and loyalty, which in ITV we strive to achieve with permanent empathy and flexibility.
6. Openness to changes, which is only possible with recurrent learning at all levels of the organization.
7. Passion for achieving excellence as individuals and as a collective group.

LOS SIETE VALORES DE ITV

SON LAS FORMAS DE PENSAR Y ACTUAR DE LAS QUE ESTAMOS CONVENCIDOS TODOS LOS QUE TRABAJAMOS EN ITV

1. Integridad y ética profesional en las relaciones humanas y comerciales, tanto internas como externas.
2. Compromiso con el medio ambiente y el crecimiento sostenible; compatible con la mejora continua de productos y procesos, y de las condiciones de trabajo.
3. Liderado por la Dirección, el triple objetivo del reconocimiento de la calidad, el medio ambiente y la seguridad laboral son una responsabilidad compartida por todos los niveles de la organización.
4. Sólo el respeto por las ideas de los demás y la transparencia en todas nuestras actuaciones permiten reconocer los errores, que son inherentes a cualquier proceso de aprendizaje.
5. El éxito se basa en una combinación de muchos factores, como rentabilidad, eficiencia, productividad, motivación y lealtad, que en ITV nos empeñamos en alcanzar con una disposición permanente de empatía y flexibilidad.
6. Apertura a los cambios, que sólo es posible con recurrentes aprendizajes en todos los niveles de la organización.
7. Pasión por lograr la excelencia como individuos y como colectivo.



THE PRESIDENT'S VISION LA VISIÓN DEL PRESIDENTE



ITV ICE makers

100% SELF-SUFFICIENT FACTORY

- TECHNOLOGY**

- SERVICE 24/7**

- IT**

- COFFEE AREA**

- RESEARCH & DEVELOPMENT**

- GYM**
WE TAKE CARE OF OURSELVES

- ENGINEERING**

- DREAMBOX**

- LEAN MAN**

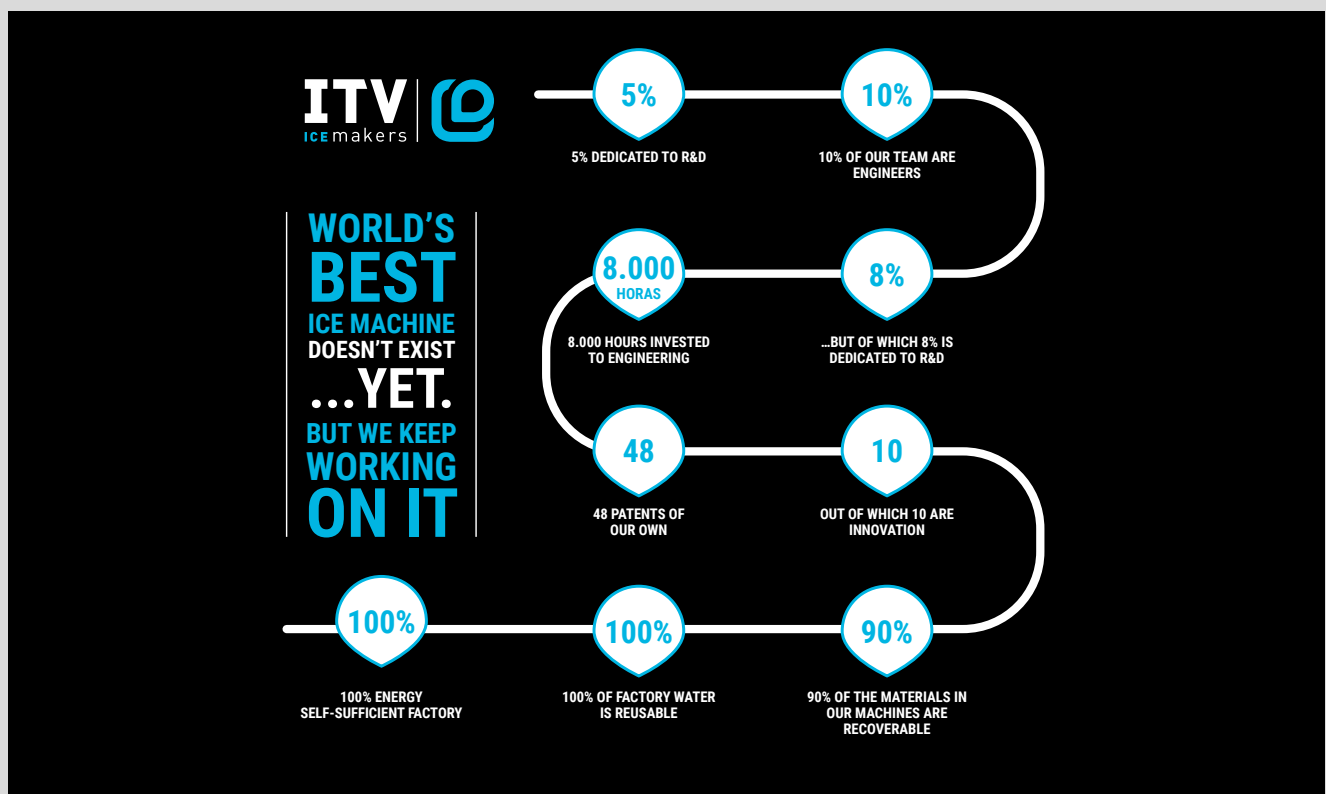
ITV ICE makers

WORLD'S BEST ICE MACHINE DOESN'T EXIST ...YET. BUT WE KEEP WORKING ON IT

- 5%** 5% DEDICATED TO R&D
- 10%** 10% OF OUR TEAM ARE ENGINEERS
- 8.000 HORAS** 8.000 HOURS INVESTED TO ENGINEERING
- 8%** ...BUT OF WHICH 8% IS DEDICATED TO R&D
- 48** 48 PATENTS OF OUR OWN
- 10** OUT OF WHICH 10 ARE INNOVATION
- 100%** 100% ENERGY SELF-SUFFICIENT FACTORY
- 100%** 100% OF FACTORY WATER IS REUSABLE
- 90%** 90% OF THE MATERIALS IN OUR MACHINES ARE RECOVERABLE

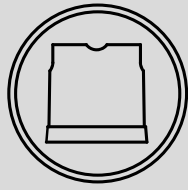

SOLID CUBE
CUBITO MACIZO

ALFA P08 - GALA P14 - DELTA MAX P21
DELTA P24 - SUPER STAR P28

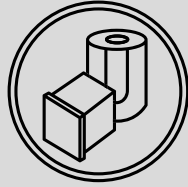

OTHERS CUBES
OTROS CUBITOS

QUASAR P34 - SPIKA P40



GRANULAR ICE AND FLAKE ICE
GRANULAR Y ESCAMAS

ICE QUEEN P46 - SCALA P56

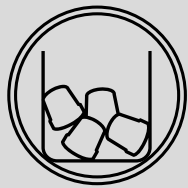

STORAGE AND TRANSPORT
ALMACENAJE Y DISTRIBUCIÓN

BINS P72 - ORBITAL BINS P81



BUILT-IN ICE MAKER
MÁQUINA DE HIELO EMPOTRADA

KITCHEN ICE P84

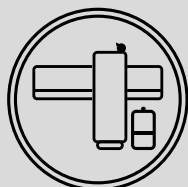

COMPLEMENTARY EQUIPMENT
EQUIPAMIENTO COMPLEMENTARIO

CASES/VITRINAS P88
WATER COOLERS/FUENTES DE AGUA P94 - TR P96
FROSTY/MONTADORAS DE NATA P98



ACCESSORIES AND FILTRATION
ACCESORIOS Y FILTROS

FILTRATION/FILTRACIÓN P100 - ACCESSORIES/ACCESORIOS P104
ENFRIADORAS/CHILLERS P106

ALFA

MAXIMUM UTILIZATION OF THE ICE VOLUME

The design of the ALFA machines seeks a compromise between the volume and the number of pieces of ice. The result is a cube with straight edges that increases productivity (more cubes per cycle) and optimizes storage. ALFA machines achieve, therefore, the best relationship between production and cost.

The elastic shower system, patented by ITV, prevents limescale problems. In order to accurately control the production, separate thermostats help regulate both the production time and the amount of ice stored.

A cleaning switch allows water to circulate without any need to connect the cooling, which enables perfect system cleaning.

The ALFA model is under the counter, and does not lose productivity when it's built-in. The door, made of stainless steel, has a damping system patented by ITV.

Standard equipment includes: ON/OFF switch; connection of water inlet; drainage; scoop to pick up the ice; Schuko cable connection; two mechanical filters.

ALFA machines produce ice with straight edges and very transparent forms, suitable for establishments that offer quality without neglecting the quantity.

(*) The working conditions of the machines are for water with a hardness of between 15°F and 40°F. For water outside these parameters and especially in the case of hard water with a high lime content, filters or descaling systems are required.



APROVECHAMIENTO MÁXIMO DEL VOLUMEN DE HIELO

El diseño de las máquinas ALFA persigue un compromiso entre el volumen y la cantidad de piezas de hielo. El resultado es un cubito de líneas rectas que incrementa la productividad (más cubitos por cada ciclo) y optimiza el almacenamiento. Las máquinas Alfa consiguen, por eso, la mejor relación entre producción y coste.

El sistema de ducha elástica, patentado por ITV, evita los problemas de cal. Para el seguimiento de la producción, sendos termostatos ayudan a regular tanto el tiempo de producción como la cantidad de hielo almacenada.

El interruptor de limpieza permite que el agua circule sin necesidad de conectar el frío, lo que facilita la perfecta limpieza del sistema.

El modelo ALFA es bajo mostrador, y no pierde productividad cuando se encastra. La puerta, de acero inoxidable, cuenta con un sistema de amortiguación patentado por ITV.

El equipamiento estándar incluye: interruptor ON/OFF; conexión de entrada de agua; desagüe; pala para recoger el hielo; cable conexión Schuko; dos filtros mecánicos.

Las máquinas ALFA producen un hielo de formas rectilíneas y muy transparente, adecuado para los establecimientos que ofrecen calidad sin descuidar la cantidad.

(*) Las condiciones de trabajo de las máquinas son para agua con un grado de dureza comprendido entre 15°F y 40°F. En caso de aguas fuera de estos parámetros y especialmente en el caso de aguas duras con un alto contenido en cal, se requiere al uso de filtros o sistemas de descalcificación.





ALFA

NDP20 | NG30 | NG35 | NG45 | NG60 | NG80 | NG110 | NG150

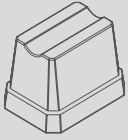

ALFA MINI
14/17cc

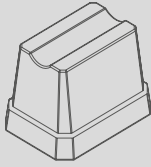

ALFA
17/21cc



R290 ICE



NDP20

350 x 475 x 595



R290 ICE



ALFA NG30

405 x 515 x 744

WITH EXTRA FEET CON PATAS +105/155mm.

DIMENSIONS (mm)
(WxDxH)



	AIR AIRE	WATER AGUA	AIR AIRE	WATER AGUA
	REF:9801U	REF:21421U	REF:16030U	REF:16031U
(1) PRODUCTION 24H (1) PRODUCCIÓN 24H	23 Kg.	21 Kg.	37 Kg.	35 Kg.
STORAGE ALMACÉN	6 Kg. 400 cubes cubitos		15 Kg. 882 cubes cubitos	
CYCLE (CUBES) CICLO (CUBITOS)	18		24	
COMPRESSOR COMPRESOR	1/4 CV		1/3 CV	
(2) MAX. POWER INPUT (1) POT. MÁX. ABSORBIDA	260 W / I		340 W / I	250 W / I
NET WEIGHT PESO NETO	32 Kg.		41 Kg.	

(1) PRODUCTION AT 20°C ROOM TEMPERATURE>15°C WATER TEMPERATURE. (2) MAXIMUM POWER ABSORBED IN CONDITIONS OF ROOM TEMPERATURE OF 43°C, ACCORDING TO THE RULES FOR CLASS T CLIMATIC CLASSIFICATION (TROPICALIZED). THE CONSUMPTION DECREASES AT LOWER ROOM TEMPERATURES.



SPRAY SYSTEM
SISTEMA DE DUCHAS



R290 ICE



ALFA NG35

465 x 595 x 789

WITH EXTRA FEET CON PATAS +105/155mm.



R290 ICE



ALFA NG45

465 x 595 x 789

WITH EXTRA FEET CON PATAS +105/155mm.



AIR AIRE	WATER AGUA	AIR AIRE	WATER AGUA
REF:16036U	REF:16037U	REF:16040U	REF:16041U
41 Kg.	40 Kg.	52 Kg.	50 Kg.
20 Kg. 1176 cubes cubitos		20 Kg. 1176 cubes cubitos	
30		30	
1/3 CV		1/2 CV	
376 W / I	310 W / I	510 W / I	430 W / I
45 Kg.		45 Kg.	

(1) PRODUCCIÓN A 20°C TEMPERATURA AMBIENTE>15°C TEMPERATURA AGUA (2) PRODUCCIÓN A 20°C TEMPERATURA AMBIENTE>15°C TEMPERATURA SEGÚN NORMAS PARA LA CLASIFICACIÓN CLIMÁTICA CLASE T (TROPICALIZADA). EL CONSUMO DISMINUYE EN TEMPERATURAS AMBIENTE INFERIORES.

ALFA

NDP20 | NG30 | NG35 | NG45 | NG60 | NG80 | NG110 | NG150

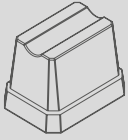

ALFA
14/17cc

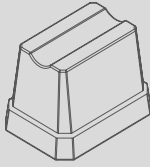

ALFA
17/21cc



R290 ICE



ALFA NG60

535 x 595 x 789

WITH EXTRA FEET CON PATAS +105/155mm.



ALFA NG80

715 x 595 x 939

WITH EXTRA FEET CON PATAS +105/155mm.

DIMENSIONS
(WxDxH)



	AIR AIRE	WATER AGUA	AIR AIRE	WATER AGUA
	REF:16050U	REF:16051U	REF: 16070	REF: 16071
(1) PRODUCTION 24H (1) PRODUCCIÓN 24H	63 Kg.	61 Kg.	77 Kg.	81 Kg.
STORAGE ALMACÉN	25 Kg. 1471 cubes cubitos		35 Kg. 2059 cubes cubitos	
CYCLE (CUBES) CICLO (CUBITOS)	45		60	
COMPRESSOR COMPRESOR	1/2 CV		1/2 CV	
(2) MAX. POWER INPUT (1) POT. MÁX. ABSORBIDA	510 W / I	430 W / I	775 W / I	
NET WEIGHT PESO NETO	56 Kg.		63 Kg.	

(1) PRODUCTION AT 20°C ROOM TEMPERATURE>15°C WATER TEMPERATURE. (2) MAXIMUM POWER ABSORBED IN CONDITIONS OF ROOM TEMPERATURE OF 43°C, ACCORDING TO THE RULES FOR CLASS T CLIMATIC CLASSIFICATION (TROPICALIZED). THE CONSUMPTION DECREASES AT LOWER ROOM TEMPERATURES.



SPRAY SYSTEM
SISTEMA DE DUCHAS



ALFA NG110

715 x 700 x 1044

WITH EXTRA FEET CON PATAS +105/155mm.



ALFA NG150

860 x 700 x 1044

WITH EXTRA FEET CON PATAS +105/155mm.



AIR AIRE	WATER AGUA	AIR AIRE	WATER AGUA
REF: 16090	REF: 16091	REF: 16140	REF: 16141
112 Kg.	117 Kg.	157 Kg.	165 Kg.
60 Kg. 3529 cubes cubitos		75 Kg. 4412 cubes cubitos	
72		128	
7/8 CV		1 3/8 CV	
1150 W / I		1350 W / I	
95 Kg.		121 Kg.	

(1) PRODUCCIÓN A 20°C TEMPERATURA AMBIENTE>15°C TEMPERATURA AGUA (2) PRODUCCIÓN A 20°C TEMPERATURA AMBIENTE>15°C TEMPERATURA SEGÚN NORMAS PARA LA CLASIFICACIÓN CLIMÁTICA CLASE T (TROPICALIZADA). EL CONSUMO DISMINUYE EN TEMPERATURAS AMBIENTE INFERIORES.

GALA

THE GOURMET CUBE MACHINE

Designed to produce the perfect, elegant cube par excellence, the range of GALA machines incorporates all of the technological advances of ITV-Ice Makers. The result is a piece of ice that is served in the vast majority of quality establishments in the West.

GALA machines have a solid internal structure that enables both maintenance and specialist intervention, thanks to its solid structure of four independent columns. The elastic shower system, patented by ITV, prevents limescale problems. In order to accurately control production, separate thermostats help regulate both the production time and the amount of ice stored.

A cleaning switch allows water to circulate without any need to connect the cooling, which enables perfect system cleaning.

The GALA model installed under the counter does not lose productivity when it's built-in. The door, made of stainless steel, has a damping system patented by ITV.

Standard equipment includes: ON/OFF switch; connection of water inlet; drainage; scoop to pick up the ice; Schuko cable connection; two mechanical filters.

The most highly regarded cube for Premium drinks, it takes just enough time to melt so as not to slow down the cooling. Ideal for wide glasses, it is not recommended in tube-glasses.

(*) The working conditions of the machines are for water with a hardness of between 15°F and 40°F. For water outside these parameters and especially in the case of hard water with a high lime content, filters or descaling systems are required.

LA MÁQUINA DEL CUBITO GOURMET

Diseñada para fabricar el cubito perfecto y elegante por antonomasia, la gama de máquinas GALA incorpora todos los avances tecnológicos de ITV-Ice Makers. El resultado es una pieza de hielo que se sirve en la inmensa mayoría de los locales de calidad en Occidente.

Las máquinas GALA presentan una sólida estructura interna que facilita tanto el mantenimiento como la intervención del especialista, gracias a su sólida estructura de cuatro columnas autónomas. El sistema de ducha elástica, patentado por ITV, evita los problemas de cal. Para el seguimiento de la producción, sendos termostatos ayudan a regular tanto el tiempo de producción como la cantidad de hielo almacenada.

El interruptor de limpieza permite que el agua circule sin necesidad de conectar el frío, lo que facilita la perfecta limpieza del sistema.

El modelo GALA instalado bajo mostrador no pierde productividad cuando se encastra. La puerta, de acero inoxidable, cuenta con un sistema de amortiguación patentado por ITV.

El equipamiento estándar incluye: interruptor ON/OFF; conexión de entrada de agua; desagüe; pala para recoger el hielo; cable conexión Schuko; dos filtros mecánicos.

El cubito más apreciado por las bebidas Premium tarda en derretirse lo justo para no ralentizar el enfriamiento. Ideal para vasos anchos, no se recomienda en los vasos de tubo.

(*) Las condiciones de trabajo de las máquinas son para agua con un grado de dureza comprendido entre 15°F y 40°F. En caso de aguas fuera de estos parámetros y especialmente en el caso de aguas duras con un alto contenido en cal, se requiere al uso de filtros o sistemas de descalcificación.





GALA

NG30 | NG35 | NG45 | NG60 | NG80 | NG110 | NG150 | MDP150 | MR400 | MR400R+RC10S

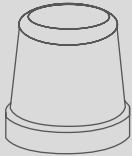

GALA
23/30cc



R290 ICE



GALA NG30

405 x 515 x 744

WITH EXTRA FEET CON PATAS +105/155mm.



R290 ICE



GALA NG35

465 x 595 x 789

WITH EXTRA FEET CON PATAS +105/155mm.

DIMENSIONS (mm)
(WxDxH)



	AIR AIRE	WATER AGUA	AIR AIRE	WATER AGUA
	REF: 13030U	REF: 13031U	REF: 13036U	REF: 13037U
(1) PRODUCTION 24H (1) PRODUCCIÓN 24H	32 Kg.	33 Kg.	40 Kg.	38 Kg.
STORAGE ALMACÉN	15 Kg. 652 cubes cubitos		20 Kg. 870 cubes cubitos	
CYCLE (CUBES) CICLO (CUBITOS)	18		24	
COMPRESSOR COMPRESOR	1/3 CV		1/3 CV	
(2) MAX. POWER INPUT (1) POT. MÁX. ABSORBIDA	340 W / l	250 W / l	376 W / l	310 W / l
NET WEIGHT PESO NETO	40 Kg.		45 Kg.	

(1) PRODUCTION AT 20°C ROOM TEMPERATURE>15°C WATER TEMPERATURE. (2) MAXIMUM POWER ABSORBED IN CONDITIONS OF ROOM TEMPERATURE OF 43°C, ACCORDING TO THE RULES FOR CLASS T CLIMATIC CLASSIFICATION (TROPICALIZED). THE CONSUMPTION DECREASES AT LOWER ROOM TEMPERATURES.



SPRAY SYSTEM
SISTEMA DE DUCHAS



R290 ICE



GALA NG45

465 x 595 x 789

WITH EXTRA FEET CON PATAS +105/155mm.



R290 ICE



GALA NG 60

535 x 595 x 789

WITH EXTRA FEET CON PATAS +105/155mm.



GALA NG 80

715 x 595 x 939

WITH EXTRA FEET CON PATAS +105/155mm.



AIR AIRE	WATER AGUA	AIR AIRE	WATER AGUA	AIR AIRE	WATER AGUA
REF: 13040U	REF: 13041U	REF: 13050U	REF: 13051	REF: 13070	REF: 13071
48 Kg.	47 Kg.	65 Kg.	56 Kg.	70 Kg.	74 Kg.
20 Kg. 870 cubes cubitos		25 Kg. 1087 cubes cubitos		35 Kg. 1522 cubes cubitos	
24		36		48	
1/2 CV		1/2 CV	3/8 CV	1/2 CV	
510 W / I	430 W / I	510 W / I	650 W / I	775 W / I	
45 Kg.		56 Kg.		63 Kg.	

(1) PRODUCCIÓN A 20°C TEMPERATURA AMBIENTE>15°C TEMPERATURA AGUA (2) PRODUCCIÓN A 20°C TEMPERATURA AMBIENTE>15°C TEMPERATURA AGUA SEGÚN NORMAS PARA LA CLASIFICACIÓN CLIMÁTICA CLASE T (TROPICALIZADA). EL CONSUMO DISMINUYE EN TEMPERATURAS AMBIENTE INFERIORES.

GALA

NG30 | NG35 | NG45 | NG60 | NG80 | NG110 | NG150 | MDP150 | MR400 | MR400R+RC10S

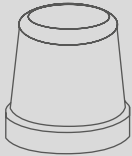

GALA
23/30cc



GALA NG110

715 x 700 x 1044

WITH EXTRA FEET CON PATAS +105/155mm.



GALA NG150

860 x 700 x 1044

WITH EXTRA FEET CON PATAS +105/155mm.

DIMENSIONS (mm)
(WxDxH)



	AIR AIRE	WATER AGUA	AIR AIRE	WATER AGUA
	REF: 13090	REF: 13091	REF: 13140	REF: 13141
(1) PRODUCTION 24H (1) PRODUCCIÓN 24H	105 Kg.	110 Kg.	148 Kg.	155 Kg.
STORAGE ALMACÉN	60 Kg. 2609 cubes cubitos		75 Kg. 3261 cubes cubitos	
CYCLE (CUBES) CICLO (CUBITOS)	60		96	
COMPRESSOR COMPRESOR	7/8 CV		1 3/8 CV	
(2) MAX. POWER INPUT (1) POT. MÁX. ABSORBIDA	1150 W / I		1350 W / I	
NET WEIGHT PESO NETO	95 Kg.		121 Kg.	

(1) PRODUCTION AT 20°C ROOM TEMPERATURE-15°C WATER TEMPERATURE. (2) MAXIMUM POWER ABSORBED IN CONDITIONS OF ROOM TEMPERATURE OF 43°C, ACCORDING TO THE RULES FOR CLASS T CLIMATIC CLASSIFICATION (TROPICALIZED). THE CONSUMPTION DECREASES AT LOWER ROOM TEMPERATURES.



SPRAY SYSTEM
SISTEMA DE DUCHAS

CONDENSING UNIT RC10S

746 x 425 x 566



GALA MDP150
775 x 625 x 805



GALA MR400
1321 x 638 x 978



GALA MR400 REMOTE
1321 x 638 x 978



STACKABLE APILABLE



STACKABLE / SINGLE PHASE 220V OPTIONAL (REF:13350)
APILABLE / OPCIONAL MONOFÁSICA 220 V (REF:13350)



AIR AIRE	WATER AGUA	AIR AIRE	WATER AGUA	AIR AIRE	RC10S
REF: 9247	REF: 9248	REF:13400	REF:13401	REF:13402	REF:20400
145 Kg.	150 Kg.	380 Kg.	380 Kg.	380 Kg.	-
MODULAR		MODULAR		MODULAR	-
84		192		192	-
1 3/8 CV		5 CV		5 CV	-
1500 W / I		3300 W / IIII	3200 W / IIII	3300 W / III	200 W / I
102 Kg.		185 Kg.		170 Kg.	40 Kg.

(1) PRODUCCIÓN A 20°C TEMPERATURA AMBIENTE>15°C TEMPERATURA AGUA (2) PRODUCCIÓN A 20°C TEMPERATURA AMBIENTE>15°C TEMPERATURA AGUA SEGÚN NORMAS PARA LA CLASIFICACIÓN CLIMÁTICA CLASE T (TROPICALIZADA). EL CONSUMO DISMINUYE EN TEMPERATURAS AMBIENTE INFERIORES.

DELTA MAX

DESIGN AND SIZE INTEGRATED IN THE PERFECT COMBINATION

Delta Max machines produce a new solid and crystalline gourmet cube, with a more modern truncated conical design that allows us to differentiate from the more classic cubes. In addition, it stands out for its large size of 40 g, adapting to the current demand of the catering industry.

The DELTA MAX range incorporates the new R290 gas cooling system, which improves machine efficiency and has an IN-OUT front ventilation system that allows recessed installation. In addition, thanks to its solid structure in 4 autonomous columns, it greatly facilitates both the maintenance and the operations of the specialists.

Delta Max ice machines also feature the ITV patented elastic shower system, preventing lime scale by vibration. It incorporates a cleaning button that allows recirculating the water with the descaler without the need for refrigeration.

The body of this model is of AISI 304 stainless steel and has the strongest door on the market, with an ITV patented opening and damping system.

(*) The working conditions of the machines are for water with a hardness of between 15°F and 40°F. For water outside these parameters and especially in the case of hard water with a high lime content, filters or descaling systems are required.

DISEÑO Y TAMAÑO INTEGRADOS EN LA COMBINACIÓN PERFECTA

Las máquinas Delta Max producen un nuevo cubito gourmet macizo y cristalino, con un diseño troncocónico más moderno que nos permite diferenciarnos de los cubitos más clásicos. Además, destaca por su gran tamaño de 40gr, adaptándonos a la demanda actual de la restauración.

La gama DELTA MAX incorpora el nuevo sistema de refrigeración con gas R290, que mejora la eficiencia de la máquina y cuenta con un sistema de ventilación frontal IN-OUT que permite la instalación encastrada. Además, gracias a su sólida estructura en 4 columnas autónomas, facilita enormemente tanto el mantenimiento como la intervención del especialista.

Las máquinas de hielo Delta Max disponen también del sistema de ducha elástica, patentado por ITV, que evita los depósitos de cal mediante vibración. Incorpora un botón de limpieza que permite recircular el agua con el desincrustante sin necesidad de refrigeración.

La carrocería de este modelo es en acero inoxidable AISI 304 y dispone de la puerta más sólida del mercado, con un sistema de apertura y amortiguación patentado por ITV.

(*) Las condiciones de trabajo de las máquinas son para agua con un grado de dureza comprendido entre 15°F y 40°F. En caso de aguas fuera de estos parámetros y especialmente en el caso de aguas duras con un alto contenido en cal, se requiere al uso de filtros o sistemas de descalcificación.





DELTA MAX

NG30 | NG35 | NG45 | NG60

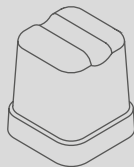

DELTA MAX
49/52cc



R290 ICE



DELTA MAX NG30

DIMENSIONS
(WxDxH)

405 x 515 x 744

WITH EXTRA FEET CON PATAS +105/155mm.



DELTA MAX NG35

465 x 595 x 789

WITH EXTRA FEET CON PATAS +105/155mm.



	AIR AIRE	WATER AGUA	AIR AIRE	WATER AGUA
	REF:14030U	REF:14031U	REF:14036U	REF:14037U
(1) PRODUCTION 24H (1) PRODUCCIÓN 24H	39 Kg.	38 Kg.	45 Kg.	38 Kg.
STORAGE ALMACÉN	15 Kg. 652 cubes cubitos		20 Kg. 870 cubes cubitos	
CYCLE (CUBES) CICLO (CUBITOS)	18		24	
COMPRESSOR COMPRESOR	1/3 CV		1/3 CV	
(2) MAX. POWER INPUT (1) POT. MÁX. ABSORBIDA	340 W / I	250 W / I	376 W / I	310 W / I
NET WEIGHT PESO NETO	40 Kg.		45 Kg.	

(1) PRODUCTION AT 20°C ROOM TEMPERATURE>15°C WATER TEMPERATURE. (2) MAXIMUM POWER ABSORBED IN CONDITIONS OF ROOM TEMPERATURE OF 43°C, ACCORDING TO THE RULES FOR CLASS T CLIMATIC CLASSIFICATION (TROPICALIZED). THE CONSUMPTION DECREASES AT LOWER ROOM TEMPERATURES.



SPRAY SYSTEM
SISTEMA DE DUCHAS



DELTA MAX NG45

465 x 595 x 789

WITH EXTRA FEET CON PATAS +105/155mm.



DELTA MAX NG60

535 x 595 x 789

WITH EXTRA FEET CON PATAS +105/155mm.



AIR AIRE	WATER AGUA	AIR AIRE	WATER AGUA
REF:14040U	REF:14041U	REF:14050U	REF:14051U
61 Kg.	52 Kg.	77 Kg.	78 Kg.
20 Kg. 870 cubes cubitos		25 Kg. 1087 cubes cubitos	
24		36	
1/2 CV		1/2 CV	
510 W / I	430 W / I	510 W / I	430 W / I
45 Kg.		56 Kg.	

(1) PRODUCCIÓN A 20°C TEMPERATURA AMBIENTE>15°C TEMPERATURA AGUA (2) PRODUCCIÓN A 20°C TEMPERATURA AMBIENTE>15°C TEMPERATURA AGUA SEGÚN NORMAS PARA LA CLASIFICACIÓN CLIMÁTICA CLASE T (TROPICALIZADA). EL CONSUMO DISMINUYE EN TEMPERATURAS AMBIENTE INFERIORES.

DELTA

TECHNOLOGY DESIGNED TO LAST

The DELTA machines present a solid internal structure that greatly facilitates both maintenance and specialist intervention, thanks to its characteristic design of four independent columns. The elastic shower system, patented by ITV, prevents limescale.

The DELTA range incorporates a control panel (at the top, to facilitate access) that houses two separate thermostats to precisely regulate both the production time and the amount of ice stored.

A cleaning switch allows water to circulate without any need to connect the cooling, which enables perfect system cleaning.

The DELTA model, with injection pump technology in its under-the counter models, does not lose productivity when it's built-in. The door is very tough and has a damping system patented by ITV. The body is made of AISI 304 stainless steel, and the EASI concept allows for dismantling with the help of a single screwdriver.

Standard equipment includes: ON/OFF switch; connection of water inlet; drainage; scoop to pick up the ice; Schuko cable connection; two mechanical filters.

90% of the hospitality industry has made a commitment to this cube. It keeps the drink cool for longer without melting and is suitable for any type of glass. Recommended for Premium drinks.

(*) The working conditions of the machines are for water with a hardness of between 15°F and 40°F. For water outside these parameters and especially in the case of hard water with a high lime content, filters or descaling systems are required.



TECNOLOGÍA PENSADA PARA DURAR

Las máquinas DELTA presentan una sólida estructura interna que facilita enormemente tanto el mantenimiento como la intervención del especialista, gracias a su característico dibujo de cuatro columnas autónomas. El sistema de ducha elástica, patentado por ITV, evita los depósitos de cal.

La gama DELTA incorpora un cuadro eléctrico (en la parte superior, para facilitar el acceso) que alberga sendos termostatos para regular con precisión tanto el tiempo de producción como la cantidad de hielo almacenada.

Un interruptor de limpieza permite que el agua circule sin necesidad de conectar el frío, lo que facilita la perfecta limpieza del sistema.

El modelo DELTA, con tecnología bomba-inyección, en sus modelos bajo mostrador no pierde productividad cuando se encastra. La puerta es muy resistente y cuenta con un sistema de amortiguación patentado por ITV. La carrocería es de acero inoxidable AISI 304, y el concepto EASI permite desmontarla con la ayuda de un solo destornillador.

El equipamiento estándar incluye: interruptor ON/OFF; conexión de entrada de agua; desagüe; pala para recoger el hielo; cable conexión Schuko; dos filtros mecánicos.

Una gran parte de la hostelería apuesta por este cubito. Mantiene la bebida más tiempo sin aguararse y es apto para cualquier tipo de vaso. Recomendado para las bebidas Premium.

(*) Las condiciones de trabajo de las máquinas son para agua con un grado de dureza comprendido entre 15°F y 40°F. En caso de aguas fuera de estos parámetros y especialmente en el caso de aguas duras con un alto contenido en cal, se requiere al uso de filtros o sistemas de descalcificación.





DELTA

NG80 | NG110 | NG150 | MDP150 | MR400 | MR400R+RC10S



DELTA
36/40cc



DELTA NG 80

715 x 595 x 939

WITH EXTRA FEET CON PATAS +105/155mm.



DELTA NG110

715 x 700 x 1044

WITH EXTRA FEET CON PATAS +105/155mm.



DELTA NG150

860 x 700 x 1044

WITH EXTRA FEET CON PATAS +105/155mm.

DIMENSIONS (mm)
(WxDxH)



	AIR AIRE	WATER AGUA	AIR AIRE	WATER AGUA	AIR AIRE	WATER AGUA
	REF:14070	REF:14071	REF:14090	REF:14091	REF:14140	REF:14141
(1) PRODUCTION 24H (1) PRODUCCIÓN 24H	81 Kg.	83 Kg.	110 Kg.	115 Kg.	150 Kg.	156 Kg.
STORAGE ALMACÉN	35 Kg. 972 cubes cubitos		60 Kg. 1667 cubes cubitos		75 Kg. 2083 cubes cubitos	
CYCLE (CUBES) CICLO (CUBITOS)	48		60		96	
COMPRESSOR COMPRESOR	1/2 CV		7/8 CV		1 3/8 CV	
(2) MAX. POWER INPUT (1) POT. MÁX. ABSORBIDA	780 W / l		1150 W / l		1350 W / l	
NET WEIGHT PESO NETO	63 Kg.		95 Kg.		121 Kg.	

(1) PRODUCTION AT 20°C ROOM TEMPERATURE>15°C WATER TEMPERATURE. (2) MAXIMUM POWER ABSORBED IN CONDITIONS OF ROOM TEMPERATURE OF 43°C, ACCORDING TO THE RULES FOR CLASS T CLIMATIC CLASSIFICATION (TROPICALIZED). THE CONSUMPTION DECREASES AT LOWER ROOM TEMPERATURES.



SPRAY SYSTEM
SISTEMA DE DUCHAS

CONDENSING UNIT RC10S

746 x 425 x 566



DELTA MDP150

775 x 625 x 805

WITH EXTRA FEET CON PATAS +105/155mm.



DELTA MR400

1321 x 638 x 978



MR400 REMOTE

1321 x 638 x 978



STACKABLE APILABLE



STACKABLE / SINGLE PHASE 220V OPTIONAL (A-REF:14350/W-REF:14351)
APILABLE / OPCIONAL MONOFÁSICA 220 V (A-REF:14350/W-REF:14351)



AIR AIRE	WATER AGUA	AIR AIRE	WATER AGUA	AIR AIRE	RC10S
REF:9357	REF:9358	REF:14400	REF:14401	REF:14402	REF:20400
153 Kg.	158 Kg.	380 Kg.	380 Kg.	380 Kg.	-
MODULAR		MODULAR		MODULAR	-
84		192		192	-
1 3/8 CV		5 CV		5 CV	-
1500 W / I		3300 W / IIII	3200 W / IIII	3300 W / III	200 W / I
102 Kg.		185 Kg.		170 Kg.	40 Kg.

(1) PRODUCCIÓN A 20°C TEMPERATURA AMBIENTE>15°C TEMPERATURA AGUA (2) PRODUCCIÓN A 20°C TEMPERATURA AMBIENTE>15°C TEMPERATURA AGUA SEGÚN NORMAS PARA LA CLASIFICACIÓN CLIMÁTICA CLASE T (TROPICALIZADA). EL CONSUMO DISMINUYE EN TEMPERATURAS AMBIENTE INFERIORES.

SUPER STAR

THE BIGGEST ICE CUBE ON THE MARKET

The SUPER STAR range responds to the demand of large-sized cubes, especially in the Night Club market. With this objective, the SUPER STAR machines base their productivity on simple and agile maintenance (structure of four autonomous columns), anti-limescale system (elastic shower).

To accurately control the production, two separate thermostats help regulate both the production time and the amount of ice stored.

A cleaning switch allows water to circulate without the need to connect the cold, which facilitates perfect system cleaning.

The SUPER STAR model is low-counter, and does not lose productivity when it's built-in. The door, made of stainless steel, has a dampening system patented by ITV.

Ideal for the typical tube-glass drinks in massive environments, although not all glass widths support the use of this cube. It is not recommended for Premium drinks.

(*) The working conditions of the machines are for water with a hardness of between 15°F and 40°F. For water outside these parameters and especially in the case of hard water with a high lime content, filters or descaling systems are required.

EL CUBITO MÁS GRANDE DEL MERCADO

La gama SUPER STAR responde a la demanda de cubitos de gran tamaño, especialmente en el mercado del Night Club. Con este objetivo, las máquinas SUPER STAR basan su productividad en un mantenimiento sencillo y ágil (estructura de cuatro columnas autónomas), sistema anti-cal (ducha elástica).

Para controlar con precisión la producción, sendos termostatos ayudan a regular tanto el tiempo de producción como la cantidad de hielo almacenada.

El interruptor de limpieza permite que el agua circule sin necesidad de conectar el frío, lo que facilita la perfecta limpieza del sistema.

El modelo SUPER STAR es bajo mostrador, y no pierde productividad cuando se encastra. La puerta, de acero inoxidable, cuenta con un sistema de amortiguación patentado por ITV.

El equipamiento estándar incluye: interruptor ON/OFF; conexión de entrada de agua; desagüe; pala para recoger el hielo; cable conexión Schuko y dos filtros mecánicos.

Ideal para las bebidas típicas del vaso-tubo en entornos masivos, aunque no todos los anchos de vaso admiten el uso de este cubito. No se recomienda para bebidas Premium.

(*) Las condiciones de trabajo de las máquinas son para agua con un grado de dureza comprendido entre 15°F y 40°F. En caso de aguas fuera de estos parámetros y especialmente en el caso de aguas duras con un alto contenido en cal, se requiere al uso de filtros o sistemas de descalcificación.





SUPER STAR

NG45 | NG60 | NG80 | NG110 | PLUS NG150 | PLUS MDP150 | PLUS MR400 | MR400R+RC10S



SUPER STAR
48/52cc

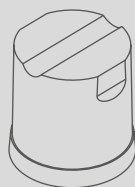

SUPER STAR PLUS
65/68c



R290 ICE



S.STAR NG45

DIMENSIONS (mm)
(AxPxH)

465 x 595 x 789

WITH EXTRA FEET CON PATAS +105/155mm.



R290 ICE



S.STAR NG60

535 x 595 x 789

WITH EXTRA FEET CON PATAS +105/155mm.



	AIR AIRE	WATER AGUA	AIR AIRE	WATER AGUA
	REF: 15040U	REF: 15041U	REF: 15050U	REF: 15051
(1) PRODUCTION 24H (1) PRODUCCIÓN 24H	41 Kg.	37 Kg.	53 Kg.	51 Kg.
STORAGE ALMACÉN	20 Kg. 417 cubes cubitos		25 Kg. 521 cubes cubitos	
CYCLE (CUBES) CICLO (CUBITOS)	18		24	
COMPRESSOR COMPRESOR	1/2 CV		1/2 CV	3/8 CV
(2) MAX. POWER INPUT (1) POT. MÁX. ABSORBIDA	510 W / I	430 W / I	510 W / I	650 W / I
NET WEIGHT PESO NETO	45 Kg.		56 Kg.	

(1) PRODUCTION AT 20°C ROOM TEMPERATURE>15°C WATER TEMPERATURE. (2) MAXIMUM POWER ABSORBED IN CONDITIONS OF ROOM TEMPERATURE OF 43°C, ACCORDING TO THE RULES FOR CLASS T CLIMATIC CLASSIFICATION (TROPICALIZED). THE CONSUMPTION DECREASES AT LOWER ROOM TEMPERATURES.



SPRAY SYSTEM
SISTEMA DE DUCHAS



S.STAR NG80

715 x 595 x 939

WITH EXTRA FEET CON PATAS +105/155mm.



S.STAR NG110

715 x 700 x 1044

WITH EXTRA FEET CON PATAS +105/155mm.



AIR AIRE	WATER AGUA	AIR AIRE	AIR AIRE
REF: 15070	REF: 15071	REF: 15090	REF: 15091
69 Kg.	71 Kg.	98 Kg.	106 Kg.
35 Kg. 729 cubes cubitos		60 Kg. 1250 cubes cubitos	
33		44	
1/2 CV		7/8 CV	
780 W / l		1150 W / l	
63 Kg.		95 Kg.	

(1) PRODUCCIÓN A 20°C TEMPERATURA AMBIENTE>15°C TEMPERATURA AGUA (2) PRODUCCIÓN A 20°C TEMPERATURA AMBIENTE>15°C TEMPERATURA AGUA SEGÚN NORMAS PARA LA CLASIFICACIÓN CLIMÁTICA CLASE T (TROPICALIZADA). EL CONSUMO DISMINUYE EN TEMPERATURAS AMBIENTE INFERIORES.

SUPER STAR

NG45 | NG60 | NG80 | NG110 | PLUS NG150 | PLUS MDP150 | PLUS MR400 | MR400R+RC10S



SUPER STAR
48/52cc

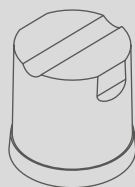

SUPER STAR PLUS
65/68c



S.STAR PLUS NG150

DIMENSIONS (mm)
(AxPxH)

860 x 700 x 1044

WITH EXTRA FEET CON PATAS +105/155mm.



S.STAR PLUS MDP150

775 x 625 x 805



STACKABLE APILABLE

	AIR AIRE	WATER AGUA	AIR AIRE	WATER AGUA
	SS-REF: 15140 SSP-REF:15146	SS-REF: 15141 SSP-REF:15147	SS-REF: 9445 SSP-REF:9873	SS-REF: 9446 SSP-REF:9876
(1) PRODUCTION 24H (1) PRODUCCIÓN 24H	155 Kg.	162 Kg.	130 Kg.	135 Kg.
STORAGE ALMACÉN	75 Kg. 1562 cubitos cubos		MODULAR	
CYCLE (CUBES) CICLO (CUBITOS)	84		66	
COMPRESSOR COMPRESOR	1 3/8 CV		1 3/8 CV	
(2) MAX. POWER INPUT (1) POT. MÁX. ABSORBIDA	1350 W / I		1800 W / I	
NET WEIGHT PESO NETO	121 Kg.		102 Kg.	

(1) PRODUCTION AT 20°C ROOM TEMPERATURE>15°C WATER TEMPERATURE. (2) MAXIMUM POWER ABSORBED IN CONDITIONS OF ROOM TEMPERATURE OF 43°C, ACCORDING TO THE RULES FOR CLASS T CLIMATIC CLASSIFICATION (TROPICALIZED). THE CONSUMPTION DECREASES AT LOWER ROOM TEMPERATURES.



SPRAY SYSTEM
SISTEMA DE DUCHAS

CONDENSING UNIT RC10S

746 x 425 x 566



S.STAR PLUS MR400

1321 x 638 x 978



S.STAR PLUS MR400 REMOTE

1321 x 638 x 978



STACKABLE / SINGLE PHASE 220V OPTIONAL (A SS-REF:15360/W SS-REF:15361)
(A SSP-REF:15350/W SSP-REF:15351)
APILABLE / OPCIONAL MONOFÁSICA 220 V (A SS-REF:15360/W SS-REF:15361)
(A SSP-REF:15350/W SSP-REF:15351)

AIR AIRE	WATER AGUA	AIR AIRE	AIR AIRE
SS-REF:15410 SSP-REF: 15400	SS-REF: 15411 SSP-REF:15401	SS-REF: 15416 SSP-REF:15402	REF:20400
400 Kg.	400 Kg.	380 Kg.	-
MODULAR		MODULAR	-
140		140	-
5 CV		5 CV	-
3400 W / IIII	3300 W / IIII	3300 W / III	200 W / I
185 Kg.		170 Kg.	40 Kg.

(1) PRODUCCIÓN A 20°C TEMPERATURA AMBIENTE>15°C TEMPERATURA AGUA (2) PRODUCCIÓN A 20°C TEMPERATURA AMBIENTE>15°C TEMPERATURA AGUA SEGÚN NORMAS PARA LA CLASIFICACIÓN CLIMÁTICA CLASE T (TROPICALIZADA). EL CONSUMO DISMINUYE EN TEMPERATURAS AMBIENTE INFERIORES.

QUASAR

ALL-TERRAIN SO THAT PRODUCTION NEVER FAILS

Designed to produce ice in the most adverse conditions of water quality and in the least suitable sites, the QUASAR machines have an average life span of 18 years. The paddle system makes electronics and water filters unnecessary. It produces a semi-hollow cube whose characteristic shape is compensated for, in order to achieve productive balance.

The QUASAR machines are “tropicalized,” so that they can operate in countries with very high average temperatures. And thanks to the absence of thermostats, the QUASAR range also operates at very low temperatures. The manufacturing design is simple, reliable and without electronics.

The body is all AISI 304 stainless steel which can be easily dismantled, with a collapsible door towards the interior. In the two versions (cooling by air and by water) it is manufactured in 220V/50Hz, 220V/60Hz and 115V/60Hz.

The range of QUASAR machines produces an unusually-shaped, can also be altered for convenience. The weight of the ice and the volume it displaces make up for the eyelet visible at one of its ends by ensuring maximum productivity.

(*) The working conditions of the machines are for water with a hardness of between 15°F and 40°F. For water outside these parameters and especially in the case of hard water with a high lime content, filters or descaling systems are required.

UN TODO-TERRENO PARA QUE NUNCA FALLE LA PRODUCCIÓN

Diseñadas para fabricar hielo en las condiciones más adversas de calidad de agua y en los emplazamientos menos adecuados, las máquinas QUASAR tienen una vida media de 18 años. El sistema de paletas hace innecesarios la electrónica y los filtros de agua. Produce un cubito semihueco cuyas formas características se compensan para lograr el equilibrio productivo.

Las máquinas QUASAR están tropicalizadas, de manera que pueden funcionar en países con temperaturas medias muy altas. Y gracias a la ausencia de termostatos, la gama QUASAR también funciona a temperaturas muy bajas. El diseño de fabricación es sencillo, fiable y sin electrónica.

La carrocería es toda de acero inoxidable AISI 304 fácilmente desmontable, con puerta abatible hacia el interior. En las dos versiones (refrigeración por aire y por agua) se fabrica a 220V/50Hz., 220V/60Hz. y 115V/60Hz.

La gama de máquinas QUASAR produce un cubito de forma singular, que además puede retocarse a conveniencia. El gramaje del hielo y el volumen que desplaza compensan el ojal visible en uno de sus extremos para asegurar la máxima productividad.

(*) Las condiciones de trabajo de las máquinas son para agua con un grado de dureza comprendido entre 15°F y 40°F. En caso de aguas fuera de estos parámetros y especialmente en el caso de aguas duras con un alto contenido en cal, se requiere al uso de filtros o sistemas de descalcificación.





QUASAR

20C | 30C | 40C | 50C | 60C | 90C | 130C | 150C

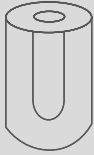

QUASAR
20cc



QUASAR 20C

401 x 506 x 643

WITH EXTRA FEET CON PATAS +57mm.



QUASAR 30C

401 x 506 x 698

WITH EXTRA FEET CON PATAS +57mm.

DIMENSIONS (mm)
(WxDxH)



	AIR AIRE	WATER AGUA	AIR AIRE	WATER AGUA
	REF:11320	REF:11321	REF:11330	REF:11331
(1) PRODUCTION 24H (1) PRODUCCIÓN 24H	22 Kg.	24 Kg.	31 Kg.	33 Kg.
STORAGE ALMACÉN	9 Kg. 450 cubes cubitos		12 Kg. 600 cubes cubitos	
CYCLE (CUBES) CICLO (CUBITOS)	15		25	
COMPRESSOR COMPRESOR	1/4 CV		1/4 CV	
(2) MAX. POWER INPUT (1) POT. MÁX. ABSORBIDA	287 W / l		293 W / l	
NET WEIGHT PESO NETO	36 Kg.		39 Kg.	

(1) PRODUCTION AT 20°C ROOM TEMPERATURE>15°C WATER TEMPERATURE. (2) MAXIMUM POWER ABSORBED IN CONDITIONS OF ROOM TEMPERATURE OF 43°C, ACCORDING TO THE RULES FOR CLASS T CLIMATIC CLASSIFICATION (TROPICALIZED). THE CONSUMPTION DECREASES AT LOWER ROOM TEMPERATURES.



PADDLE SYSTEM
SISTEMA DE PALETAS



QUASAR 40C

401 x 506 x 698

WITH EXTRA FEET CON PATAS +57mm.



QUASAR 50C

513 x 557 x 811

WITH EXTRA FEET CON PATAS +105/155mm.



AIR AIRE	WATER AGUA	AIR AIRE	WATER AGUA
REF:11340	REF:11341	REF:11350	REF:11351
38 Kg.	39 Kg.	48 Kg.	51 Kg.
12 Kg. 600 cubes cubitos		15 Kg. 1250 cubes cubitos	
25		35	
1/4 CV		1/3 CV	
421 W / I		401 W / I	
40 Kg.		48 Kg.	

(1) PRODUCCIÓN A 20°C TEMPERATURA AMBIENTE > 15°C TEMPERATURA AGUA (2) MÁXIMA POTENCIA ABSORBIDA EN CONDICIONES DE TEMPERATURA AMBIENTE DE 43°C, SEGÚN NORMAS PARA LA CLASIFICACIÓN CLIMÁTICA CLASE T (TROPICALIZADA). EL CONSUMO DISMINUYE EN TEMPERATURAS AMBIENTE INFERIORES.

QUASAR

20C | 30C | 40C | 50C | 60C | 90C | 130C | 150C

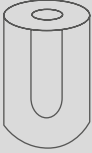

QUASAR
20cc

DIMENSIONS
(WxDxH)



QUASAR 60C

594 x 557 x 934

WITH EXTRA FEET CON PATAS +105/155mm.



QUASAR 90C

673 x 557 x 984

WITH EXTRA FEET CON PATAS +105/155mm.



	AIR AIRE	WATER AGUA	AIR AIRE	WATER AGUA
	REF:11360	REF:11361	REF:11390	REF:11391
(1) PRODUCTION 24H (1) PRODUCCIÓN 24H	55 Kg.	60 Kg.	75 Kg.	81 Kg.
STORAGE ALMACÉN	30 Kg. 1500 cubes cubitos		37 Kg. 1850 cubes cubitos	
CYCLE (CUBES) CICLO (CUBITOS)	45		55	
COMPRESSOR COMPRESOR	3/8 CV		1/2 CV	
(2) MAX. POWER INPUT (1) POT. MÁX. ABSORBIDA	480 W / l		775 W / l	
NET WEIGHT PESO NETO	55 Kg.		60 Kg.	

(1) PRODUCTION AT 20°C ROOM TEMPERATURE>15°C WATER TEMPERATURE. (2) MAXIMUM POWER ABSORBED IN CONDITIONS OF ROOM TEMPERATURE OF 43°C, ACCORDING TO THE RULES FOR CLASS T CLIMATIC CLASSIFICATION (TROPICALIZED). THE CONSUMPTION DECREASES AT LOWER ROOM TEMPERATURES.



PADDLE SYSTEM
SISTEMA DE PALETAS



QUASAR 130C

844 x 557 x 984

WITH EXTRA FEET CON PATAS +105/155mm.



QUASAR 150C

818 x 762 x 1398

WITH EXTRA FEET CON PATAS +117/140mm.



AIR AIRE	WATER AGUA	AIR AIRE	WATER AGUA
REF:11310	REF:11311	REF:11370	REF:11371
122 Kg.	130 Kg.	135 Kg.	140 Kg.
50 Kg. 2500 cubes cubitos		230 Kg. 11500 cubes cubitos	
80		80	
3/4 CV		3/4 CV	
800 W / I		800 W / I	
80 Kg.		95 Kg.	

(1) PRODUCCIÓN A 20°C TEMPERATURA AMBIENTE > 15°C TEMPERATURA AGUA (2) MÁXIMA POTENCIA ABSORBIDA EN CONDICIONES DE TEMPERATURA AMBIENTE DE 43°C, SEGÚN NORMAS PARA LA CLASIFICACIÓN CLIMÁTICA CLASE T (TROPICALIZADA). EL CONSUMO DISMINUYE EN TEMPERATURAS AMBIENTE INFERIORES.

SPIKA

DESIGNED TO STAND UP TO THE DEVILISH PACE OF FAST-FOOD

Quick to produce cubes that cool the drink at full speed (in seconds the drink is cold). The SPIKA ITV range responds to the needs of fast-food establishments with machines ideal for large consumption of ice. The dual Energy Star and ARHI certification guarantees maximum energy efficiency. A special switch enables easy and rapid cleaning.

SPIKA machines are presented in under the counter versions (New Generation technology), or in modules with the option of stacking them and duplicating production in the same space. SPIKA machines are vertical evaporating, with the water distributor patented by ITV which produces ice in the form of dice and half dice.

The oversized condenser is optimal for warm climates in both versions (cooling by air and by water). The manufacturing system is simple, reliable, and suitable for chalky areas and difficult working conditions. In both versions it is manufactured in 220V/50Hz, 220V/60Hz and 115V/60Hz.

The SPIKA range produces the piece of ice in the form of dice or half dice; it is one of the best-known and most widely used cubes in the world. It cools drinks very quickly: the cooling ratio is close to the 100% mark. You can enjoy your drink in seconds.

(*) The working conditions of the machines are for water with a hardness of between 15°F and 40°F. For water outside these parameters and especially in the case of hard water with a high lime content, filters or descaling systems are required.



DISEÑADA PARA RESISTIR EL EXIGENTE RITMO DEL FAST-FOOD

Rápida a la hora de producir y cubitos que enfrían la bebida a toda velocidad (en segundos su bebida helada). La gama SPIKA de ITV responde a las necesidades de los establecimientos de fast-food con máquinas ideales para grandes consumos de hielo. La certificación ARHI garantiza la máxima eficiencia energética. Un interruptor específico facilita una limpieza sencilla y ágil. Las máquinas SPIKA se presentan en bajo mostrador (tecnología New Generation), o bien en módulos con la opción de apilarlos y duplicar la producción en el mismo espacio.

Las máquinas SPIKA son de evaporador vertical, con el distribuidor de agua patentado por ITV que fabrica los cubitos de dados y medios dados.

El condensador sobredimensionado es óptimo para climas cálidos en las dos versiones (refrigeración por aire y por agua). El sistema de fabricación es sencillo, fiable, y apto para zonas calcáreas y condiciones difíciles de trabajo. En las dos versiones se fabrica a 220V/50Hz., 220V/60Hz. y 115V/60Hz.

La gama SPIKA produce la pieza de hielo en forma de dado y de medio dado; se trata de uno de los cubitos más conocidos y utilizados en el mundo. Enfría muy rápidamente la bebida: el ratio de enfriamiento roza el 100%. Podrá disfrutar en segundos de su refresco muy frío.

(*) Las condiciones de trabajo de las máquinas son para agua con un grado de dureza comprendido entre 15°F y 40°F. En caso de aguas fuera de estos parámetros y especialmente en el caso de aguas duras con un alto contenido en cal, se requiere al uso de filtros o sistemas de descalcificación.





SPIKA

NG60 | NG90 | NG110 | NG140 | MS220 | MS220R+RC5S | MS300 SLIM | MS410 | MS410R+RC10S

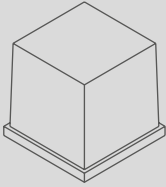

FULL DICE
CUBITO DADO
13cc

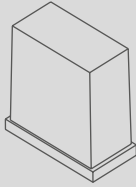

HALF DICE
CUBITO 1/2 DADO
6,5cc



SPIKA NG60

535 x 595 x 789

WITH EXTRA FEET CON PATAS +105/155mm.

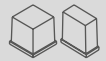

SPIKA NG90

660 x 700 x 832

WITH EXTRA FEET CON PATAS +105/155mm.

DIMENSIONS (mm)
(WxDxH)



	AIR AIRE	WATER AGUA	AIR AIRE	WATER AGUA
	H-REF: 17060 F-REF: 18060	H-REF: 17061 F-REF: 18061	H-REF: 17090 F-REF: 18090	H-REF: 17091 F-REF: 18091
(1) PRODUCTION 24H (1) PRODUCCIÓN 24H	59 Kg.	62 Kg.	90 Kg.	93 Kg.
STORAGE ALMACÉN	20 Kg. 1500 / 3000 cubes cubitos		35 Kg. 2692 / 5384 cubes cubitos	
CYCLE (CUBES) CICLO (CUBITOS)	75 / 150		120 / 240	
COMPRESSOR COMPRESOR	1/4 CV		1/3 + CV	
(2) MAX. POWER INPUT (1) POT. MÁX. ABSORBIDA	430 W / I	470 W / I	550 W / I	580 W / I
NET WEIGHT PESO NETO	52 Kg.		68 Kg.	

(1) PRODUCTION AT 20°C ROOM TEMPERATURE>15°C WATER TEMPERATURE. (2) MAXIMUM POWER ABSORBED IN CONDITIONS OF ROOM TEMPERATURE OF 43°C, ACCORDING TO THE RULES FOR CLASS T CLIMATIC CLASSIFICATION (TROPICALIZED). THE CONSUMPTION DECREASES AT LOWER ROOM TEMPERATURES.



VERTICAL SYSTEM
SISTEMA VERTICAL



SPIKA NG110

660 x 700 x 832

WITH EXTRA FEET CON PATAS +105/155mm.



SPIKA NG140

762 x 762 x 832

WITH EXTRA FEET CON PATAS +105/155mm.



AIR AIRE	WATER AGUA	AIR AIRE	WATER AGUA
H-REF: 17110 F-REF: 18110	H-REF: 17111 F-REF: 18111	H-REF: 17140 F-REF: 18140	H-REF: 17141 F-REF: 18141
110 Kg.	113 Kg.	136 Kg.	140 Kg.
35 Kg. 2692 / 5384 cubes cubitos		45 Kg. 3461 / 6923 cubes cubitos	
120 / 240		144 / 288	
1/2 CV		3/4 CV	
600 W / I	650 W / I	710 W / I	730 W / I
71 Kg.		85 Kg.	

(1) PRODUCCIÓN A 20°C TEMPERATURA AMBIENTE > 15°C TEMPERATURA AGUA (2) MÁXIMA POTENCIA ABSORBIDA EN CONDICIONES DE TEMPERATURA AMBIENTE DE 43°C, SEGÚN NORMAS PARA LA CLASIFICACIÓN CLIMÁTICA CLASE T (TROPICALIZADA). EL CONSUMO DISMINUYE EN TEMPERATURAS AMBIENTE INFERIORES.

SPIKA

NG60 | NG90 | NG110 | NG140 | MS220 | MS220R+RC5S | MS300 SLIM | MS410 | MS410R+RC10S

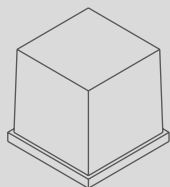

FULL DICE
CUBITO DADO
13cc

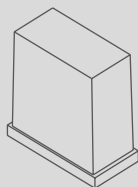

HALF DICE
CUBITO 1/2 DADO
6,5cc

CONDENSING UNIT RC5S

619 x 427 x 417



SPIKA MS220R

762 x 620 x 500



SPIKA MS220

762 x 620 x 500

DIMENSIONS (mm)
(WxDxH)



STACKABLE APILABLE



	AIR AIRE	WATER AGUA	AIR AIRE	RC5S
	H-REF:17200 F-REF:18200	H-REF:17201 F-REF:18201	H-REF:17216 F-REF:18216	REF: 17212
(1) PRODUCTION 24H (1) PRODUCCIÓN 24H	220 Kg.	236 Kg.	220 Kg.	-
STORAGE ALMACÉN	MODULAR		MODULAR	-
CYCLE (CUBES) CICLO (CUBITOS)	200 / 400		200 / 400	-
COMPRESSOR COMPRESOR	3/4 CV		3/4 CV	-
(2) MAX. POWER INPUT (1) POT. MÁX. ABSORBIDA	1120 W / I		1120 W / I	100 W / I
NET WEIGHT PESO NETO	85 Kg.		85 Kg.	30 Kg.

(1) PRODUCTION AT 20°C ROOM TEMPERATURE>15°C WATER TEMPERATURE. (2) MAXIMUM POWER ABSORBED IN CONDITIONS OF ROOM TEMPERATURE OF 43°C, ACCORDING TO THE RULES FOR CLASS T CLIMATIC CLASSIFICATION (TROPICALIZED). THE CONSUMPTION DECREASES AT LOWER ROOM TEMPERATURES.



VERTICAL SYSTEM
SISTEMA VERTICAL

CONDENSING UNIT RC10S

746 x 425 x 566

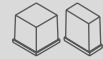

SPIKA MS410R

762 x 620 x 760



SPIKA MS410

762 x 620 x 760



SPIKA MS300 SLIM

559 x 621 x 659



STACKABLE / SINGLE PHASE 220V OPTIONAL (AH-REF:17406/WH-REF:17407)
(AF-REF:18406/WF-REF:18407)
APILABLE / OPCIONAL MONOFÁSICA 220 V (AH-REF:17406/WH-REF:17407)
(AF-REF:18406/WF-REF:18407)

AIR AIRE	WATER AGUA	AIR AIRE	WATER AGUA	AIR AIRE	RC10S
H-REF: 17250 F-REF: 18250	H-REF: 17251 F-REF: 18251	H-REF: 17400 F-REF: 18400	H-REF: 17401 F-REF: 18401	H-REF: 17412 F-REF: 18412	REF:20400
300 Kg.	320 Kg.	405 Kg.	416 Kg.	405 Kg.	-
MODULAR		MODULAR		MODULAR	-
240 / 480		400 / 800		400 / 800	-
1/4 CV		1 1/2 CV		1 1/2 CV	-
1400 W / I		1800 W / I-III		1800 W / I- III	200 W / I
70 Kg.		105 Kg.		105 Kg.	40 Kg.

(1) PRODUCCIÓN A 20°C TEMPERATURA AMBIENTE > 15°C TEMPERATURA AGUA (2) MÁXIMA POTENCIA ABSORBIDA EN CONDICIONES DE TEMPERATURA AMBIENTE DE 43°C, SEGÚN NORMAS PARA LA CLASIFICACIÓN CLIMÁTICA CLASE T (TROPICALIZADA). EL CONSUMO DISMINUYE EN TEMPERATURAS AMBIENTE INFERIORES.

ICE QUEEN

GRANULAR ICE IN THE FISH MARKET, THE SPA OR THE COCKTAIL SHAKER!

The ICE QUEEN series produces ice diced or granular ice, while benefiting from its vertical cylindrical evaporator and high resistance spindle. In addition to its traditional uses in the food and health sectors, granular ice has been keenly incorporated into other activities such as spas and therapeutic treatments.

ICE QUEEN machines can produce two types of ice:

DIAMOND ICE OR DRY GRANULAR ICE, models IQ50C and IQ85C, specially designed for cocktails. The ideal type of ice for the latest trend in international hospitality: cocktails!

WET GRANULAR ICE, produced by all of the other machines in the ICE QUEEN range. This ice has a higher percentage of moisture, which means it is perfect for supermarkets, for transporting fish, fruit or vegetables, and for industrial applications in the food sector.

The oversized condenser in both versions (air-cooled and water-cooled) is well-suited to hot climates. The ice production system is simple, reliable, and with no electronics, as well as being prepared for hard water areas and difficult operating conditions.

The easily detachable body is made entirely from stainless steel AISI 304. The ICE QUEEN machine comes complete with a water filter, scoop and ice distributor "in situ". Both versions are manufactured with 220V/50Hz and 220V/60Hz and three phase 380V.

The ICE QUEEN machines allow you to regulate the moisture content depending on the different applications and uses allocated to the ice which it produces, or according to user's own preferences.

(*) The working conditions of the machines are for water with a hardness of between 15°F and 40°F. For water outside these parameters and especially in the case of hard water with a high lime content, filters or descaling systems are required.

HIELO GRANULAR EN LA PESCADERÍA, EL SPA O LA COCTELERA

La serie ICE QUEEN produce hielo troceado o granular, valiéndose de un evaporador cilíndrico vertical y husillo de alta resistencia. A los usos tradicionales de este hielo en los sectores de la alimentación y sanitario se han incorporado con fuerza otras actividades como los spa, tratamientos terapéuticos y laboratorios.

El hielo que puede obtenerse de estas máquinas es de dos tipos:

DIAMOND ICE O HIELO GRANULAR SECO, modelos IQ50C e IQ85C, especialmente diseñado para coctelería. El hielo más idóneo para la nueva tendencia en la hostelería internacional: ¡el cocktail!.

HIELO GRANULAR HÚMEDO, producido por las máquinas del resto de la gama ICE QUEEN. Tiene un porcentaje mayor de humedad siendo perfecto para supermercados, transporte de pescado, fruta y verdura, así como aplicaciones industriales en el sector de la alimentación.

A mayor producción mayor tamaño del hielo. El condensador sobre-dimensionado es óptimo para climas calientes en las dos versiones (refrigeración por aire o por agua). El sistema de fabricación de hielo es sencillo, fiable y sin electrónica, preparado para zonas de agua calcárea y condiciones difíciles de trabajo.

La carrocería es toda de acero inoxidable AISI 304 fácilmente desmontable. En las dos versiones se fabrica a 220V/50Hz. y 220V/60Hz. y trifásica 380V.

Las máquinas ICE QUEEN permiten regular el grado de humedad del hielo según las distintas aplicaciones y usos al que destine la producción, y a gusto de las preferencias del usuario.

(*) Las condiciones de trabajo de las máquinas son para agua con un grado de dureza comprendido entre 15°F y 40°F. En caso de aguas fuera de estos parámetros y especialmente en el caso de aguas duras con un alto contenido en cal, se requiere al uso de filtros o sistemas de descalcificación.



ICE QUEEN

50C | 85C | 135C | 150 | 200 | 300F | 400 | 550 | G550 | G550S+RCU15 | G850S | G850 CO2 | 1100* | G1100 | G1100S+RCU30



DIAMOND ICE



GRANULAR ICE



R290 ICE



R290 ICE



ICE QUEEN 50C

465 x 595 x 784

WITH EXTRA FEET CON PATAS +105/155mm.

ICE QUEEN 85C

465 x 595 x 784

WITH EXTRA FEET CON PATAS +105/155mm.

DIMENSIONS (mm)
(WxDxH)



	AIR AIRE	WATER AGUA	AIR AIRE	WATER AGUA
	REF:10220U	REF:10221	REF:9133U	REF:9134
(1) PRODUCTION 24H (1) PRODUCCIÓN 24H	74 Kg.	50 Kg.	94 Kg.	88 Kg.
STORAGE ALMACÉN	20 Kg.		20 Kg.	
COMPRESSOR COMPRESOR	1/4 CV		1/4 CV	
(2) MAX. POWER INPUT (1) POT. MÁX. ABSORBIDA	423 W / I	505 W / I	470 W / I	533 W / I
NET WEIGHT PESO NETO	55 Kg.		58 Kg.	

(1) PRODUCTION AT 20°C ROOM TEMPERATURE-15°C WATER TEMPERATURE. (2) MAXIMUM POWER ABSORBED IN CONDITIONS OF ROOM TEMPERATURE OF 43°C, ACCORDING TO THE RULES FOR CLASS T CLIMATIC CLASSIFICATION (TROPICALIZED). THE CONSUMPTION DECREASES AT LOWER ROOM TEMPERATURES.



ICE QUEEN 135C

515 x 550 x 1355

WITH EXTRA FEET CON PATAS +80mm.



ICE QUEEN 150

515 x 550 x 486



AIR AIRE	WATER AGUA	AIR AIRE	WATER AGUA
REF:9061	REF:9062	REF:9063	REF:9064
135 Kg.	139 Kg.	140 Kg.	145 Kg.
60 Kg.		MODULAR	
3/8 CV		3/8 CV	
640 W / I		650 W / I	
75 Kg.		45 Kg.	

(1) PRODUCCIÓN A 20°C TEMPERATURA AMBIENTE > 15°C TEMPERATURA AGUA (2) MÁXIMA POTENCIA ABSORBIDA EN CONDICIONES DE TEMPERATURA AMBIENTE DE 43°C, SEGÚN NORMAS PARA LA CLASIFICACIÓN CLIMÁTICA CLASE T (TROPICALIZADA). EL CONSUMO DISMINUYE EN TEMPERATURAS AMBIENTE INFERIORES.

ICE QUEEN

50C | 85C | 135C | 150 | 200 | 300F | 400 | 550 | G550 | G550S+RCU15 | G850S | G850 CO2 | 1100* | G1100 | G1100S+RCU30



DIAMOND ICE



GRANULAR ICE



ICE QUEEN 200

515 x 550 x 575



ICE QUEEN 300F

559 x 622 x 712

DIMENSIONS
(WxDxH)



	AIR AIRE	WATER AGUA	AIR AIRE
	REF:9031	REF:9032	REF:10501F
(1) PRODUCTION 24H (1) PRODUCCIÓN 24H	220 Kg.	225 Kg.	310 Kg.
STORAGE ALMACÉN	MODULAR		MODULAR
COMPRESSOR COMPRESOR	1/2 CV		1 CV
(2) MAX. POWER INPUT (1) POT. MÁX. ABSORBIDA	780 W / I		1260 W / I
NET WEIGHT PESO NETO	52 Kg.		84 Kg.

(1) PRODUCTION AT 20°C ROOM TEMPERATURE-15°C WATER TEMPERATURE. (2) MAXIMUM POWER ABSORBED IN CONDITIONS OF ROOM TEMPERATURE OF 43°C, ACCORDING TO THE RULES FOR CLASS T CLIMATIC CLASSIFICATION (TROPICALIZED). THE CONSUMPTION DECREASES AT LOWER ROOM TEMPERATURES.



ICE QUEEN 400

675 x 550 x 660



SINGLE PHASE 220V OPTIONAL (A-REF:9033/W-REF:9034)
OPCIONAL MONOFÁSICA 220 V (A-REF:9033/W-REF:9034)



ICE QUEEN 550

675 x 550 x 800



SINGLE PHASE 220V OPTIONAL (A-REF:9067/W-REF:9068)
OPCIONAL MONOFÁSICA 220 V (A-REF:9067/W-REF:9068)

AIR AIRE	WATER AGUA	AIR AIRE	WATER AGUA
REF:9131	REF:9132	REF:9078	REF:9079
390 Kg.	395 Kg.	565 Kg.	570 Kg.
MODULAR		MODULAR	
1 3/8 CV		1 1/2 CV	
1300 W / I-III		1850 W / I-III	
82 Kg.		105 Kg.	

(1) PRODUCCIÓN A 20°C TEMPERATURA AMBIENTE > 15°C TEMPERATURA AGUA (2) MÁXIMA POTENCIA ABSORBIDA EN CONDICIONES DE TEMPERATURA AMBIENTE DE 43°C, SEGÚN NORMAS PARA LA CLASIFICACIÓN CLIMÁTICA CLASE T (TROPICALIZADA). EL CONSUMO DISMINUYE EN TEMPERATURAS AMBIENTE INFERIORES.

IQN 300



NUGGET ICE

NUGGET ICE. THE NEW TREND IN COCKTAIL

Ice Queen N machines produce nugget ice, perfect for combinations, as it gently mixes the flavors of the drink without watering it down.

Its moisture content (10%) and its compact texture allows it to keep drinks cold longer. Its main feature is its shape, halfway between a cube and crushed ice, although normally chopped. It is hard inside and soft on the outside and its use has been extended to cool, for example, fruit juices or yogurts at food exhibitions.

The Ice Queen N range has a high-efficiency evaporator, which reduces energy consumption and produces more ice. In addition, it has a self-diagnosis system with LED signaling to indicate the operation of the machine and warn of possible failures in order to be able to respond as quickly as possible.

The body is made of AISI 304 stainless steel and it has an on and off button for ease of use.

This is the new trend in hospitality. A crunchy ice that does not detract from the flavor of the drink and that can be enjoyed in any leisure environment, as well as in the most select places.



HIELO NUGGET. LA NUEVA TENDENCIA EN COCTELERÍA

Las máquinas Ice Queen N producen hielo nugget, perfecto para combinados, ya que mezcla suavemente los sabores de la bebida sin aguarla.

Su grado de humedad (10%) y su textura compacta le permite mantener las bebidas frías más tiempo. Su principal característica es la forma, a medio camino entre el cubito y el hielo triturado, aunque de troceado regular. Es duro en su interior y suave por fuera, y el uso se ha extendido para enfriar, por ejemplo, los zumos de frutas o los yogures en exposiciones de alimentos.

La gama Ice Queen N tiene un evaporador de alta eficiencia que permite reducir el consumo de energía y obtener una mayor producción de hielo. Además, cuenta con un sistema de auto diagnóstico con señalización de leds para indicar el funcionamiento de la máquina y alertar de posibles averías, con el objetivo de poder dar una respuesta lo más rápido posible.

La carrocería es de acero inoxidable AISI 304 y dispone de un botón de encendido y apagado para mayor comodidad del usuario.

Se trata de la nueva tendencia en hostelería. Un hielo crujiente que no resta sabor a la bebida y que se puede disfrutar en cualquier ambiente de ocio, así como en los locales más selectos.



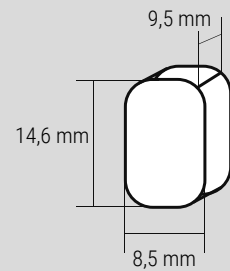

90% DRY 90% SECO
(+/- 2%)

IQN 300

DIMENSIONS
(WxDxH)

559 x 622 x 712

	AIR AIRE
	REF:10501N
(1) PRODUCTION 24H (1) PRODUCCIÓN 24H	310 Kg.
STORAGE ALMACÉN	MODULAR
COMPRESSOR COMPRESOR	1 CV
(2) MAX. POWER INPUT (1) POT. MÁX. ABSORBIDA	1260 W / I
NET WEIGHT PESO NETO	84 Kg.



(1) PRODUCTION AT 20°C ROOM TEMPERATURE-15°C WATER TEMPERATURE. (2) MAXIMUM POWER ABSORBED IN CONDITIONS OF ROOM TEMPERATURE OF 43°C, ACCORDING TO THE RULES FOR CLASS T CLIMATIC CLASSIFICATION (TROPICALIZED). THE CONSUMPTION DECREASES AT LOWER ROOM TEMPERATURES.
(1) PRODUCCIÓN A 20°C TEMPERATURA AMBIENTE-15°C TEMPERATURA AGUA (2) MÁXIMA POTENCIA ABSORBIDA EN CONDICIONES DE TEMPERATURA AMBIENTE DE 43°C, SEGÚN NORMAS PARA LA CLASIFICACIÓN CLIMÁTICA CLASE T (TROPICALIZADA). EL CONSUMO DISMINUYE EN TEMPERATURAS AMBIENTE INFERIORES.

ICE QUEEN

50C | 85C | 135C | 150 | 200 | 400 | 550 | G550 | G550S+RCU15 | G850S | G850 CO2 | 1100* | G1100 | G1100S+RCU30



DIAMOND ICE



GRANULAR ICE

CONDENSING UNIT RCU15

1108 x 574 x 690



GENERATOR IQ 550 SPLIT

525 x 410 x 815



GIQ 550 SPLIT

525 x 410 x 815



GENERATOR IQ850 SPLIT

525 x 410 x 815

DIMENSIONS (mm)
(WxDxH)



*REQUIREMENTS: EVAPORATION TEMP. -15°, 2675W. 2300 F/h. WITHOUT REFRIGERATOR SYSTEM. TO CONNECT WITH COOLING EQUIPMENT *REQUERIMIENTOS: TEMP. EVAPORACIÓN -15°, 2675W. 2300 F/h. SIN EQUIPO FRIGORÍFICO. PARA CONECTAR A CENTRAL DE FRÍO



REFRIGERATION REQUIREMENTS 3400W/EVAPORATING TEMPERATURE -23°C/ TO CONNECT WITH COOLING EQUIPMENT *REQUERIMIENTOS FRIGORÍFICO 3400W/TEMP. EVAPORACIÓN -23°C/ PARA CONECTAR A CENTRAL DE FRÍO



	AIR AIRE	AIR AIRE	RCU15	AIR AIRE
	REF:9141	REF:9141	REF:10604	REF:10305
(1) PRODUCTION 24H (1) PRODUCCIÓN 24H	565 Kg.	565 Kg.	-	850 Kg.
STORAGE ALMACÉN	MODULAR	MODULAR	-	MODULAR
COMPRESSOR COMPRESOR	NO	NO	1/2 CV	NO
(2) MAX. POWER INPUT (1) POT. MÁX. ABSORBIDA	600 W / I-III	600 W / III	800 W / III	600 W / I
NET WEIGHT PESO NETO	70 Kg.	70 Kg.	73 Kg.	88 Kg.

(1) PRODUCTION AT 20°C ROOM TEMPERATURE-15°C WATER TEMPERATURE. (2) MAXIMUM POWER ABSORBED IN CONDITIONS OF ROOM TEMPERATURE OF 43°C, ACCORDING TO THE RULES FOR CLASS T CLIMATIC CLASSIFICATION (TROPICALIZED). THE CONSUMPTION DECREASES AT LOWER ROOM TEMPERATURES.



**CONDENSING UNIT
RCU30**

1108 x 574 x 815



**GENERATOR
IQ850 CO₂ SPLIT**

525 x 410 x 815



REFRIGERATION REQUIREMENT 3400 W/
EVAPORATING TEMPERATURE -24°C / TO
CONNECT WITH COOLING EQUIPMENT
*REQUERIMIENTO FRIGORÍFICO 3400 W/
TEMPERATURA EVAPORACIÓN -24°C/
PARA CONECTAR A CENTRAL DE FRÍO



ICE QUEEN 1100

1335 x 610 x 815



**GENERATOR
IQ1100 SPLIT**

790 x 505 x 815



*REQUIREMENTS: EVAPORATION TEMP. -15°, 5350W. 4600
F/h. WITHOUT REFRIGERATOR SYSTEM. TO CONNECT WITH
COOLING EQUIPMENT *REQUERIMIENTOS: TEMP. EVAPO-
RACIÓN -15°, 5350W. 4600 F/h. SIN EQUIPO FRIGORÍFICO.
PARA CONECTAR A CENTRAL DE FRÍO



GIQ 1100 SPLIT

790 x 505 x 815



AIR AIRE	AIR AIRE	WATER AGUA	AIR AIRE	AIR AIRE	RCU30
REF:10304	REF:9065	REF:9066	REF:9145	REF:9145	REF:10603
850 Kg.	1125 Kg.	1130 Kg.	1121 Kg.	1121 Kg.	-
MODULAR	MODULAR		MODULAR	MODULAR	-
NO	2 x 1/2 CV		NO	NO	4 CV
600 W / I	3700 W / III		1200 W / III	1200 W / III	2395 W / III
88 Kg.	210 Kg.		140 Kg.	140 Kg.	131 Kg.

(1) PRODUCCIÓN A 20°C TEMPERATURA AMBIENTE > 15°C TEMPERATURA AGUA (2) MÁXIMA POTENCIA ABSORBIDA EN CONDICIONES DE TEMPERATURA AMBIENTE DE 43°C, SEGÚN NORMAS PARA LA CLASIFICACIÓN CLIMÁTICA CLASE T (TROPICALIZADA). EL CONSUMO DISMINUYE EN TEMPERATURAS AMBIENTE INFERIORES.

SCALA

QUALITY AND RELIABILITY IN INDUSTRIAL QUANTITIES

The SCALA machine, which produces flat flakes that are very cold and dry, in large-scale production, is the most compact on the market. Simplicity, functionality and competitiveness sustain its recognised prestige in the world of cold production equipment. Its construction with non-corrosive, lightweight and high strength materials ensures durability and ease of maintenance. The machine is designed to reduce maintenance operations, guaranteeing its useful life and extending its longevity.

All of ITV's experience in the world of refrigeration and ice applied to the design of the SCALA for use in more industrial setting.

The SCALA range is the safest and most profitable option for chilling perishable foods; food transformation processes; sanitary healthcare; agriculture and distribution; zoos and theme parks; fish farms; fish, baking and meat industries, etc.

The SCALA machines' operation is based on a static cylinder which is free from swivel joints (helical reamer) coupled with a milling tool that detaches the ice without any strained or forced movements.

SCALA range offers salt doser option to increase flake thickness.

Other features:

- . Electronic stop system
- . Electrical control panel
- . Direct drive gear motor
- . Submerged pump
- . Low water level safety device
- . Stainless steel soleplate evaporator
- . Expanded polyurethane insulation
- . Centered bearing
- . Ice deflection tray
- . Homogeneous water distributor
- . Controller to detect: low water level; rotation in the opposite direction; temperature increase due to an overloaded motor, or due to overfull storage

While producing large quantities of ice for industrial use, the SCALA range of machines maintains an excellent standard of quality throughout the manufacturing process.

SEGURIDAD Y CALIDAD EN CANTIDADES INDUSTRIALES

SCALA es la máquina de hielo de escama plana, muy fría y seca, con grandes producciones, más compacta del mercado. Simplicidad, funcionalidad y competitividad sustentan su reconocido prestigio en el mundo del equipamiento de frío. Fabricada con materiales no corrosivos, ligeros y de gran resistencia, asegura una larga durabilidad y un mantenimiento sencillo. Una máquina diseñada para disminuir las intervenciones de mantenimiento, asegurando la vida activa de la máquina y prolongando su longevidad. Toda la experiencia de ITV en el mundo de la refrigeración y el hielo aplicado al diseño de la SCALA para el uso más industrial

La gama SCALA es la opción más segura y rentable para enfriar alimentos perecederos; procesos de transformación de alimentos; instalaciones sanitarias y hospitales; agricultura y distribución; zoológicos y parques temáticos; piscifactorías; industrias de pesca, panaderas, cárnicas...

El funcionamiento de las máquinas SCALA está basado en un cilindro estático sin juntas giratorias (Helical Reamer) y con una fresa que despega el hielo sin tensiones ni esfuerzos.

La gama SCALA dispone de la opción de dosificador de sal que aumenta el grosor de la escama.

Otras características:

- . Sistema de paro electrónico
- . Cuadro eléctrico de regulación
- . Motorreductor de ataque directo
- . Bomba sumergida
- . Seguridad de falta de agua
- . Bancada de acero inoxidable evaporador
- . Aislamiento de poliuretano expandido
- . Cojinete centrado
- . Bandeja deflectora de hielo
- . Distribuidor de agua homogéneo
- . Controlador para detectar: falta de agua; giro al revés; subida de temperatura por sobreesfuerzo en el reductor, y por llenado de almacenaje.

Las máquinas SCALA mantienen un excelente estándar de calidad durante todo el proceso de grandes cantidades de hielo para uso industrial.



SCALA

INDUSTRIAL RANGE
COMPACT UNITS 0,4Tm | 10Tm

ICE GENERATOR WITH CONDENSING UNIT | GENERADOR DE HIELO COMPACTO



FLAKE ICE | HIELO ESCAMAS
 1,5-2,2mm THICKNESS | ESPESOR



SCALA 400

1100 x 700 x 760



SCALA 600

1250 x 750 x 835

DIMENSIONS (mm)
 (WxDxH)



	REF:10001	REF:10025
(1) PRODUCTION 24H (1) PRODUCCIÓN 24H	≈ 400 Kg.	≈ 600 Kg.
POWER POTENCIA	1 3/4 CV	2 CV
COOLING REQUIREMENT REQ. FRIGORÍFICOS	2200 W	3300 W
NET WEIGHT PESO NETO	160 Kg.	210 Kg.

FRESH WATER, PRODUCTION IN OPTIMAL CONDITIONS: ROOM TEMPERATURE 20°C | WATER TEMPERATURE 15°C | ICE TEMPERATURE -5°C/-10°C, THINCKNESS 2mm. | 1 LITRE OF WATER=1Kg. OF ICE. FEATURES OF CONDENSING UNITS: SEE EACH MODEL | OTHER PRODUCTION UP TO 50Tm. CHECK WITH YOUR SUPPLIER.



SCALA 1T

1350 x 1050 x 1000



SCALA 1'5T

1405 x 1645 x 1447



REF:10002	REF:10029
≈ 1000 Kg.	≈ 1500 Kg.
4 CV	3 + 3 CV
5500 W	8250 W
390 Kg.	490 Kg.

AGUA DULCE. PRODUCCIONES EN CONDICIONES ÓPTIMAS A 20°C TEMPERATURA AMBIENTE > 15°C TEMPERATURA AGUA. TEMPERATURA DEL HIELO -5°C/-10°C ESPESOR 2mm. 1LITRO DE AGUA=1KG. DE HIELO, EJEMPLO UNA PRODUCCIÓN DE 1000 KG./24h.= CONSUMO .CARACTERÍSTICAS UNIDAD CONDENSADORA: CONSULTAR SEGÚN MODELOS. PRODUCCIÓN HASTA 15Tm. OTRAS PRODUCCIONES HASTA 50Tm.: CONSULTAR.

SCALA

INDUSTRIAL RANGE
COMPACT UNITS 0,4Tm | 10Tm

ICE GENERATOR WITH CONDENSING UNIT | GENERADOR DE HIELO COMPACTO



FLAKE ICE | HIELO ESCAMAS
 1,5-2,2mm THICKNESS | ESPESOR



SCALA 2T

1404 x 1613 x 1600



SCALA 3T

2600 x 1150 x 1300

DIMENSIONS (mm)
 (WxDxH)



	REF:10003	REF:10004
(1) PRODUCTION 24H (1) PRODUCCIÓN 24H	≈ 2000 Kg.	≈ 3000 Kg.
POWER POTENCIA	4 + 4 CV	15 CV
COOLING REQUIREMENT REQ. FRIGORÍFICOS	11000 W	16500 W
NET WEIGHT PESO NETO	513 Kg.	660 Kg.

FRESH WATER, PRODUCTION IN OPTIMAL CONDITIONS: ROOM TEMPERATURE 20°C | WATER TEMPERATURE 15°C | ICE TEMPERATURE -5°C/-10°C, THINCKNESS 2mm. | 1 LITRE OF WATER=1Kg. OF ICE. FEATURES OF CONDENSING UNITS: SEE EACH MODEL | OTHER PRODUCTION UP TO 50Tm. CHECK WITH YOUR SUPPLIER



SCALA 5T

3705 x 1150 x 1300



SCALA 10T

5575 x 1300 x 1920



REF:10005	REF:10006
≈ 5000 Kg.	≈ 10000 Kg.
30 CV	45 CV
27500 W	55000 W
1500 Kg.	1950 Kg.

AGUA DULCE. PRODUCCIONES EN CONDICIONES ÓPTIMAS A 20°C TEMPERATURA AMBIENTE > 15°C TEMPERATURA AGUA. TEMPERATURA DEL HIELO -5°C/-10°C ESPESOR 2mm. 1LITRO DE AGUA=1KG. DE HIELO, EJEMPLO UNA PRODUCCIÓN cc. DE 1000 KG./24h.= CONSUMO . CARACTERÍSTICAS UNIDAD CONDENSADORA: CONSULTAR SEGÚN MODELOS. PRODUCCIÓN HASTA 15Tm. OTRAS PRODUCCIONES HASTA 50Tm.: CONSULTAR.

SCALA

INDUSTRIAL RANGE
SPLIT UNITS 0,4Tm | 50Tm

ICE GENERATOR (WITHOUT CONDENSING UNIT) | GENERADOR DE HIELO (SIN UNIDAD CONDENSADORA)



FLAKE ICE | HIELO ESCAMAS
1,5-2,2mm THICKNESS | ESPESOR



SCALA 400 SPLIT

1100 x 700 x 760



SCALA 600 SPLIT

1250 x 750 x 835

DIMENSIONS (mm)
(WxDxH)



	REF:10022	REF:10024
(1) PRODUCTION 24H (1) PRODUCCIÓN 24H	≈ 400 Kg.	≈ 600 Kg.
POWER POTENCIA	190 W	190 W
COOLING REQUIREMENT REQ. FRIGORÍFICOS	2200 W/h	3300 W/h
NET WEIGHT PESO NETO	100 Kg.	120 Kg.

FRESH WATER, PRODUCTION IN OPTIMAL CONDITIONS: ROOM TEMPERATURE 20°C | WATER TEMPERATURE 15°C | ICE TEMPERATURE -5°C/-10°C, THINCKNESS 2mm. | 1 LITRE OF WATER=1Kg. OF ICE. FEATURES OF CONDENSING UNITS: SEE EACH MODEL | OTHER PRODUCTION UP TO 50Tm. SEE DETAILS



SCALA 1T SPLIT

1050 x 750 x 870



SCALA 1'5T SPLIT

1050 x 750 x 1050



REF:10008	REF:10023
≈ 1000 Kg.	≈ 1500 Kg.
190 W	200 W
5500 W/h	8250 W/h
170 Kg.	200 Kg.

AGUA DULCE. PRODUCCIONES EN CONDICIONES ÓPTIMAS A 20°C TEMPERATURA AMBIENTE > 15°C TEMPERATURA AGUA. TEMPERATURA DEL HIELO -5°C/-10°C ESPESOR 2mm. 1LITRO DE AGUA=1KG. DE HIELO, EJEMPLO UNA PRODUCCIÓN cc. DE 1000 KG./24h.= CONSUMO . CARACTERÍSTICAS UNIDAD CONDENSADORA: CONSULTAR SEGÚN MODELOS. PRODUCCIÓN HASTA 15Tm. OTRAS PRODUCCIONES HASTA 50Tm.: CONSULTAR.

SCALA

INDUSTRIAL RANGE
SPLIT UNITS 0,4Tm | 50Tm

ICE GENERATOR (WITHOUT CONDENSING UNIT) | GENERADOR DE HIELO (SIN UNIDAD CONDENSADORA)



FLAKE ICE | HIELO ESCAMAS
1,5-2,2mm THICKNESS | ESPESOR



SCALA 2T SPLIT

1050 x 750 x 1080



SCALA 3T SPLIT

1050 x 750 x 1300

DIMENSIONS (mm)
(WxDxH)



	REF:10010	REF:10012
(1) PRODUCTION 24H (1) PRODUCCIÓN 24H	≈ 2000 Kg.	≈ 3000 Kg.
POWER POTENCIA	200 W	200 W
COOLING REQUIREMENT REQ. FRIGORÍFICOS	11000 W/h	16500 W/h
NET WEIGHT PESO NETO	230 Kg.	280 Kg.

FRESH WATER, PRODUCTION IN OPTIMAL CONDITIONS: ROOM TEMPERATURE 20°C | WATER TEMPERATURE 15°C | ICE TEMPERATURE -5°C/-10°C, THICKNESS 2mm. | 1 LITRE OF WATER=1Kg. OF ICE. FEATURES OF CONDENSING UNITS: SEE EACH MODEL | OTHER PRODUCTION UP TO 50Tm. CHECK WITH YOUR SUPPLIER.



SCALA 5T SPLIT

1850 x 1150 x 1250



SCALA 10T SPLIT

1850 x 1150 x 1800



SCALA 15T SPLIT

2700 x 1800 x 2100



REF:10014	REF:10016	REF:10018
≈ 5000 Kg.	≈ 10000 Kg.	≈ 15000 Kg.
435 W	435 W	1000 W
27500 W/h	55000 W/h	82500 W/h
800 Kg.	1400 Kg.	2500 Kg.

AGUA DULCE. PRODUCCIONES EN CONDICIONES ÓPTIMAS A 20°C TEMPERATURA AMBIENTE > 15°C TEMPERATURA AGUA. TEMPERATURA DEL HIELO -5°C/-10°C ESPESOR 2mm. 1LITRO DE AGUA=1KG. DE HIELO, EJEMPLO UNA PRODUCCIÓN DE 1000 KG./24h.= CONSUMO .CARACTERÍSTICAS UNIDAD CONDENSADORA: CONSULTAR SEGÚN MODELOS. PRODUCCIÓN HASTA 15Tm. OTRAS PRODUCCIONES HASTA 50Tm.: CONSULTAR.

SCALA

INDUSTRIAL RANGE
REMOTE UNITS 0,4Tm | 10Tm

SCALA WITH REMOTE CONDESING UNIT | UNIDAD CONDENSADORA REMOTA



FLAKE ICE | HIELO ESCAMAS
1,5-2,2mm THICKNESS | ESPESOR

CONDENSING UNIT RCU400

574 x 1108 x 690



+



SCALA 400 REMOTE

1100 x 700 x 760

CONDENSING UNIT RCU600

574 x 1108 x 690



+



SCALA 600 REMOTE

1250 x 750 x 835

DIMENSIONS (mm)
(WxDxH)



	SCALA 400 SPLIT	RCU 400	SCALA 600 SPLIT	RCU 600
	REF:10030		REF:10031	
PRODUCTION 24H PRODUCCIÓN 24H	≈ 400 Kg.	-	≈ 600 Kg.	-
COMPRESSOR HP COMPRESOR HP	1 3/4 CV	-	2 CV	-
Ø ICE OUTLET Ø SALIDA HIELO	326 mm	-	326 mm	-
POWER POTENCIA	190 W	1235 W	190 W	2160 W
NET WEIGHT PESO NETO	100 Kg.	84 Kg.	120 Kg.	86 Kg.

FRESH WATER, PRODUCTION IN OPTIMAL CONDITIONS: ROOM TEMPERATURE 20°C | WATER TEMPERATURE 15°C | ICE TEMPERATURE -5°C/-10°C, THINCKNESS 2mm. | 1 LITRE OF WATER=1Kg. OF ICE. FEATURES OF CONDENSING UNITS: SEE EACH MODEL | OTHER PRODUCTION UP TO 50Tm. CHECK WITH YOUR SUPPLIER.



**CONDENSING UNIT
RCU1000**

574 x 1108 x 1319



SCALA 1T REMOTE

1050 x 750 x 870



**CONDENSING UNIT
RCU1500**

574 x 1613 x 1297



SCALA 1'5T REMOTE

1050 x 750 x 1060



SCALA 1T SPLIT	RCU 1000	SCALA 1'5T SPLIT	RCU 1500
REF:10009		REF:10035	
≈ 1000 Kg.	-	≈ 1500 Kg.	-
4 CV	-	3 +3 CV	-
480 mm	-	480 mm	-
190 W	2395 W	200 W	6440 W
170 Kg.	129 Kg.	200 Kg.	308 Kg.

AGUA DULCE. PRODUCCIONES EN CONDICIONES ÓPTIMAS A 20°C TEMPERATURA AMBIENTE > 15°C TEMPERATURA AGUA. TEMPERATURA DEL HIELO -5°C/-10°C ESPESOR 2mm. 1LITRO DE AGUA=1KG. DE HIELO, EJEMPLO UNA PRODUCCIÓN DE 1000 KG./24h.= CONSUMO .CARACTERÍSTICAS UNIDAD CONDENSADORA: CONSULTAR SEGÚN MODELOS. PRODUCCIÓN HASTA 15Tm. OTRAS PRODUCCIONES HASTA 50Tm.: CONSULTAR.

SCALA

GAMA INDUSTRIAL
REMOTE UNITS 0,4Tm | 10Tm

REMOTE CONDENSING UNNIT | UNIDAD CONDENSADORA REMOTA

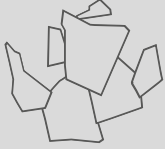

FLAKE ICE | HIELO ESCAMAS
1,5-2,2mm THICKNESS | ESPESOR

CONDENSING UNIT RCU2000

574 x 1613 x 1297



+



SCALA 2T REMOTE

1050 x 750 x 1080

CONDENSING UNIT RCU3000

1250 x 1500 x 1300



+



SCALA 3T REMOTE

1050 x 750 x 1300

DIMENSIONS (mm)
(WxDxH)



	SCALA 2000 SPLIT	RCU 400	SCALA 3000 SPLIT	RCU 600
	REF:10011		REF:10013	
PRODUCTION 24H PRODUCCIÓN 24H	≈ 2000 Kg.	-	≈ 3000 Kg.	-
COMPRESSOR HP COMPRESOR HP	4+4 CV	-	15 CV	-
Ø ICE OUTLET Ø SALIDA HIELO	480 mm	-	480 mm	-
POWER POTENCIA	200 W	7670 W	200 W	12150 W
NET WEIGHT PESO NETO	230 Kg.	263 Kg.	280 Kg.	238 Kg.



**CONDENSING UNIT
RCU5000**

1150 x 1755 x 1600



SCALA 5T REMOTE

1050 x 1150 x 1300



**CONDENSING UNIT
RCU10000**

1150 x 3600 x 1600



SCALA 10T REMOTE

1850 x 1150 x 1800



SCALA 5000 SPLIT	RCU 1000	SCALA 10000 SPLIT	RCU 1500
REF:10015		REF:10017	
≈ 5000 Kg.	-	≈ 10000 Kg.	-
30 CV	-	45 CV	-
900 mm	-	900 mm	-
435 W	23040 W	435 W	30600 W
800 Kg.	451 Kg.	1400 Kg.	471 Kg.

SCALA

INDUSTRIAL RANGE
CO₂ SPLIT UNITS 0,4Tm | 3Tm

ICE GENERATOR (WITHOUT CONDENSING UNIT) | GENERADOR DE HIELO (SIN UNIDAD CONDENSADORA)



FLAKE ICE | HIELO ESCAMAS
1,5-2,2mm THICKNESS | ESPESOR



CO₂ ICE



SCALA 400 CO₂ SPLIT

1090 x 700 x 760



SCALA 600 CO₂ SPLIT

1250 x 750 x 835

DIMENSIONS (mm)
(WxDxH)



	REF:10032	REF:10033
(1) PRODUCTION 24H (1) PRODUCCIÓN 24H	≈ 400 Kg.	≈ 600 Kg.
POWER POTENCIA	190 W	190 W
COOLING REQUIREMENT REQ. FRIGORÍFICOS	2200 W/h	3300 W/h
NET WEIGHT PESO NETO	100 Kg.	120 Kg.

FRESH WATER, PRODUCTION IN OPTIMAL CONDITIONS: ROOM TEMPERATURE 20°C | WATER TEMPERATURE 15°C | ICE TEMPERATURE -5°C/-10°C, THINNESS 2mm. | 1 LITRE OF WATER=1Kg. OF ICE. FEATURES OF CONDENSING UNITS: SEE EACH MODEL | OTHER PRODUCTION UP TO 50Tm. CHECK WITH YOUR SUPPLIER.



SCALA 1T CO₂ SPLIT

1050 x 750 x 870



SCALA 2T CO₂ SPLIT

1050 x 750 x 1080



SCALA 3T CO₂ SPLIT

1050 x 750 x 1300



REF:10027	REF:10028	REF:10034
≈ 1000 Kg.	≈ 2000 Kg.	≈ 3000 Kg.
190 W	200 W	200 W
5500 W/h	11000 W/h	16500 W/h
170 Kg.	230 Kg.	280 Kg.

AGUA DULCE. PRODUCCIONES EN CONDICIONES ÓPTIMAS A 20°C TEMPERATURA AMBIENTE > 15°C TEMPERATURA AGUA. TEMPERATURA DEL HIELO -5°C/-10°C ESPESOR 2mm. 1LITRO DE AGUA=1KG. DE HIELO, EJEMPLO UNA PRODUCCIÓN DE 1000 KG./24h.= CONSUMO .CARACTERÍSTICAS UNIDAD CONDENSADORA: CONSULTAR SEGÚN MODELOS. PRODUCCIÓN HASTA 15Tm. OTRAS PRODUCCIONES HASTA 50Tm.: CONSULTAR.

BIN

STORE AND TRANSPORT YOUR ICE SAFELY AND HYGIENICALLY WITHOUT LOSING A SINGLE CUBE

The ice storage bins are an indispensable element in order to produce large amounts of ice. An adequate storage bin avoids problems of space, saves work and money and guarantees an abundant stock.

We have a wide range of storage bins to adapt to any ITV ice machine and to respond to all requirements. The bins help you remove the ice, avoiding spills. Additionally, the transfer of ice is three times faster, which saves time and work. Some bins have a door at the bottom that lets you first remove the oldest ice, thus achieving better rotation and ice quality.

The SCS150, SCS300, SCD400, SCD600 and SCD800 bins have some transporting carts that eliminate the need to handle the ice for transport, since it falls directly into the carts. Thus the transfer of the ice is much easier and you avoid lifting heavy trays of ice.

ALMACENAR Y TRASLADAR EL HIELO CON SEGURIDAD E HIGIENE SIN PERDER NI UN CUBITO

Los depósitos para almacenaje de hielo (SILOS), constituyen un elemento indispensable para cubrir grandes demandas de hielo. Un depósito adecuado evita problemas de espacio, ahorra trabajo, dinero y garantiza un abundante stock.

Disponemos de una amplia gama de depósitos para adaptarse a cualquier máquina de hielo ITV y responder a todas las necesidades. Los SILOS facilitan el proceso de retirada de hielo, evitando derrames, además el traslado del hielo es tres veces más rápido con lo que se ahorra trabajo y tiempo. Algunos SILOS disponen de una puerta en la parte inferior que permite sacar primero el hielo más antiguo, con lo que conseguimos una mayor rotación y calidad del hielo.

Los SILOS SCS150, SCS300, SCD400, SCD600 Y SCD800 disponen de unos carritos transportadores que eliminan la necesidad de manipular el hielo para su transporte, ya que éste cae directamente en los carros. Así facilitamos el traslado del hielo y evitamos levantar pesadas cubetas de hielo.





BIN

S80 | S130 | S160 | S220 | S350 | S400 | S500

BIN S80

BIN S130

BIN S160

BIN S220

DIMENSIONS (mm)
(WxDxH)

685 x 555 x 870

762 x 819 x 740

559 x 872 x 1122

762 x 819 x 1071

WITH EXTRA FEET CON PATAS +95mm.

WITH EXTRA FEET CON PATAS +160mm

WITH EXTRA FEET CON PATAS +160mm.

WITH EXTRA FEET CON PATAS +160mm.



STORAGE (100%)
ALMACÉN (100%)

STORAGE (AHRI 80%)
ALMACÉN (AHRI 80%)

NET WEIGHT
PESO NETO

80 Kg	160 Kg.	181 Kg.	230 Kg.
64 Kg.	128 Kg.	145 Kg.	184 Kg.
50 Kg.	52 Kg.	54 Kg.	56 Kg.

ALL THE BINS CAN BE SUPPLIED WITH OR WITHOUT COVER | TODOS LOS SILOS SE PUEDEN SUMINISTRAR CON O SIN TAPA

BIN S350

1067 x 819 x 1071

WITH EXTRA FEET CON PATAS +160mm.



BIN S400

1219 x 819 x 1071

WITH EXTRA FEET CON PATAS +160mm.



BIN S500

1321 x 872 x 1122

WITH EXTRA FEET CON PATAS +160mm.



340 Kg.	390 Kg.	480 Kg.
272 Kg.	312 Kg.	384 Kg.
69 Kg.	75 Kg.	94 Kg.

BIN WITH CART | CON CARRO

SCS150 | SCS300 | SCD400 | SCD600 | SCD800
EASY CART | 6 BUCKETS KIT CONJUNTO 6 CESTAS

DIMENSIONS (mm)
(WxDxH)

BIN SCS150

762 x 1016 x 1320

BIN SCS300

762 x 1016/1163* x 1865

*WITH DOOR | CON PUERTA

BIN SCD400

1524 x 1016/1163* x 1520

*WITH DOOR | CON PUERTA



STORAGE (100%) ALMACÉN (100%)	140 Kg. + CART 112 KG	300 Kg. + CART 112 KG	413 Kg. + 2 CART 224 KG
STORAGE (AHRI 80%) ALMACÉN (AHRI 80%)	110 Kg. + CART 112 KG	240 Kg. + CART 112 KG	330 Kg. + 2 CART 224 KG
NET WEIGHT PESO NETO	75 Kg.	95 Kg.	140 Kg.

BIN SCD600

1524 x 1016/1163* x 1820

*WITH DOOR | CON PUERTA



BIN SCD800

1524 x 1016/1163* x 2084

*WITH DOOR | CON PUERTA



EASY CART KIT 6 CESTAS

620 x 1054 x 722/887 with handle



		EASY CART	ACCESSORY (*) 6 BUCKET KIT
		REF: 19551	REF: 30501
617 Kg. + 2 CART 224 KG	812 Kg + 2 CART 224 KG	112 Kg.	70 Kg.
494 Kg. + 2 CART 224 KG	650 Kg. + 2 CART 224 KG	-	-
160 Kg.	175 Kg.	35 Kg.	8 Kg.

(*) BUCKET KIT SOLD SEPARATELY | (*) KIT DE CESTAS SUMINISTRADAS POR SEPARADO

COMBINATIONS



RECOMMENDED
RECOMENDADO



POSSIBLE (NOT OPTIMIZED)
POSIBLE (NO OPTIMIZADO)



STACKED
APILADO



SIDE BY SIDE
EN PARALELO

BINS | DEPÓSITOS



S80



S130



S160



S220



S350



S400



S500

Nº MÁQUINAS

1 2

1 2

1 2

1 2

1 2

1 2

1 2

(*) MDP150 GALA/DELTA		Ref:19573		Ref:19501	Ref:19511	Ref:19521	Ref:19530
(*) MR400 GALA/DELTA							Ref:19530
MP145 PULSAR	Ref:19162			Ref:19504			
(**) MS 220 SPIKA	Ref:19573		Ref:19501	Ref:19511	Ref:19521	Ref:19521	Ref:19534
MS 300 SLIM SPIKA	Ref:19574	Ref:19562	Ref:19509	Ref:19514	Ref:19528		
(**) MS 410 SPIKA	Ref:19573		Ref:19501	Ref:19511	Ref:19521	Ref:19521	Ref:19534
ICE QUEEN 150	Ref:19161	Ref:19575	Ref:19563	Ref:19502	Ref:19512	Ref:19522	
ICE QUEEN 200	Ref:19161	Ref:19575	Ref:19563	Ref:19502	Ref:19512	Ref:19522	
IQ 300 N/F	Ref:19575		Ref:19502	Ref:19512	Ref:19522	Ref:19522	Ref:19532
ICE QUEEN 400	Ref:19575		Ref:19502	Ref:19512	Ref:19523	Ref:19523	Ref:19532
(*) ICE QUEEN 550	Ref:19575		Ref:19502	Ref:19512	Ref:19523	Ref:19523	Ref:19532
ICE QUEEN 1100							Ref:19535
G ICE QUEEN 550	Ref:19575		Ref:19502	Ref:19512	Ref:19522	Ref:19522	Ref:19532
G ICE QUEEN 850 CO2	Ref:19575		Ref:19502	Ref:19512	Ref:19522	Ref:19522	Ref:19532
G ICE QUEEN 1100				Ref:19518	Ref:19529	Ref:19529	Ref:19535
SCALA 400/SCALA 400 SPLIT					Ref:19524	Ref:19524	Ref:19533
(*) SCALA 600/SCALA 600 SPLIT							Ref:19533
SCALA 1000/1500/2000/3000 SPLIT							Ref:19539
SCALA COMPACT 1000							

COMBINACIONES



RECOMMENDED
RECOMENDADO



POSSIBLE (NOT OPTIMIZED)
POSIBLE (NO OPTIMIZADO)



STACKED
APILADO



SIDE BY SIDE
EN PARALELO

BINS WITH CART | DEPÓSITOS CON CARRO



SCS150



SCS300



SCD400



SCD600



SCD800

Nº MÁQUINAS

	SCS150		SCS300		SCD400		SCD600		SCD800						
	1	2	1	2	1	2	1	2	1	2					
(*) MDP150 GALA/DELTA			Ref:19652			Ref:19653			Ref:19543			Ref:19544			Ref:19548
(*) MR400 GALA/DELTA							Ref:19546			Ref:19547			Ref:19548		
MP145 PULSAR			Ref:19665												
(**) MS 220 SPIKA			Ref:19652			Ref:19653			Ref:19543			Ref:19544			Ref:19545
MS 300 SLIM SPIKA			Ref:19659			Ref:19658			Ref:19543						
(**) MS 410 SPIKA			Ref:19652			Ref:19653			Ref:19543			Ref:19544			Ref:19545
ICE QUEEN 150			Ref:19651												
ICE QUEEN 200			Ref:19651			Ref:19650				Ref:19540					
IQ 300 N/F			Ref:19651			Ref:19650				Ref:19540					Ref:19542
ICEQUEEN 400			Ref:19651			Ref:19650				Ref:19540					Ref:1942
(*) ICE QUEEN 550			Ref:19651			Ref:19650				Ref:19540					Ref:19542
ICE QUEEN 1100									Ref:19540			Ref:19541			Ref:19542
G ICE QUEEN 550			Ref:19651			Ref:19650			Ref:19540			Ref:19541			Ref:19542
G ICE QUEEN 850 CO2			Ref:19651			Ref:19650			Ref:19540			Ref:19541			Ref:19542
G ICE QUEEN 1100									Ref:19540			Ref:19541			Ref:19542
SCALA 400/SCALA 400 SPLIT									Ref:19543			Ref:19544			Ref:19545
(*) SCALA 600/SCALA 600 SPLIT									Ref:19543			Ref:19544			Ref:19545
SCALA 1000/1500/2000/3000 SPLIT									Ref:19543			Ref:19544			Ref:19545
SCALA COMPACT 1000															

STACKING SYSTEM SISTEMA DE APILADO

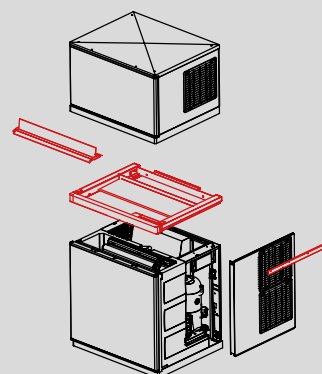
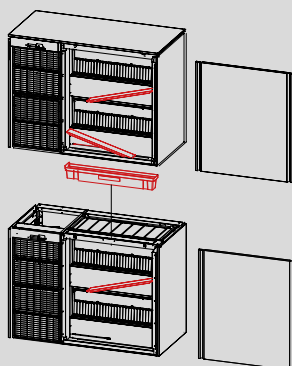

*CONNECTING KIT FOR STACKING
*KIT DE UNIÓN PARA APILADO

ICE BAGGER EMBOLSADORA DE HIELO

DIMENSIONS (mm)
(WxDxH)

IBK-1

357 x 274 x 730



BAGS CAPACITY
CAPACIDAD BOLSAS

NET WEIGHT
PESO NETO

REF: 19820

4 Kg.

7 Kg.

ORBITAL BIN

INDUSTRIAL RANGE | GAMA INDUSTRIAL

STORE AND SUPPLY FLAKE ICE IN LARGE QUANTITIES

They are designed to store and supply, inside refrigerated chambers, the large quantities of flake ice that the SCALA range of machines produces. For use in logistics centers for fresh fish, fish markets, ports, food industries or superstore headquarters.

The exclusive design of the hopper and cone-shaped ice scatterer prevent the formation of holes and blocks of ice. Additionally the bin includes a spindle with simultaneous movement and rotation that moves the ice, facilitating the drainage of melting water, breaking blocks, and preventing the formation of caves. Dry, loose ice is thus obtained.

The bin has an automatic dispensing system that saves time in handling ice and decreases losses in the melting of dispensed ice that isn't utilized. An optional weighing system can be included.

ALMACENAR Y SUMINISTRAR ESCAMAS PLANAS DE HIELO EN GRANDES CANTIDADES

Están diseñados para almacenar y suministrar, dentro de las cámaras refrigeradas, las grandes cantidades de hielo en escama plana que producen la gama de máquinas SCALA. De aplicación en centros logísticos de pescado fresco, lonjas, puertos, industrias alimentarias o centrales de hipermercados.

El diseño exclusivo de la tolva y del cono dispersor de hielo evitan la formación de huecos y bloques de hielo. Adicionalmente; el silo incorpora un husillo con movimiento simultáneo de traslación y rotación que mueve el hielo facilitando el escurrido de agua de fundición, rompiendo bloques, y evitando la formación de cavernas. Se obtiene así un hielo suelto y seco.

El silo dispone de un sistema de dispensado automático que ahorra tiempos en el manejo del hielo disminuyendo mermas por fundición de hielo dispensado y no utilizado. Opcionalmente se puede incorporar un sistema de pesado.

ORBITAL BIN

INDUSTRIAL RANGE | GAMA INDUSTRIAL

	SS221	SS322	SS422	SS523	SS732
	REF: 19840	REF: 19848	REF: 19849	REF: 19843	REF: 19844
CAPACITY CAPACIDAD	2 Tn	3 Tn	4 Tn	5 Tn	7 Tn
VOLUME VOLUMEN	5,96 m ³	7,95 m ³	9,94 m ³	11,9 m ³	14 m ³
EXTERNAL DIAMETER DIÁMETRO EXTERIOR	2250 mm	2250 mm	2250 mm	2250 mm	3080 mm
BASE HEIGHT ALTURA BASE	1000 mm	1000 mm	1000 mm	1000 mm	1000 mm
TOTAL HEIGHT ALTURA TOTAL	2500 mm	3000 mm	3500 mm	4000 mm	3000 mm
ICE DISCHARGE CAUDAL EXTRACCIÓN	4000 Kg/h	4000 Kg/h	4000 Kg/h	4000 Kg/h	9000 Kg/h

ICE EXTRACTION SPINDLE AND ADDITIONAL HOPPER INCLUDED. OPTIONAL: ELECTRONIC CONTROL SPEED DISCHARGE.
THE ORBITAL SILOS MUST BE INSTALLED INSIDE REFRIGERATED CHAMBERS WITH AN INTERIOR TEMPERATURE BETWEEN -3°C AND -10°C AND MAINTAINING CONSTANT HUMIDITY FOR PROPER STORAGE AND DISPENSING OF ICE. STORING AND DISPENSING FRESH ICE PRODUCED ON THE SAME DAY IS RECOMMENDED. AVOID STORING ICE FOR MORE THAN 24 HOURS TO PREVENT POSSIBLE FORMATION OF BLOCKS.



SS1033

SS1242

SS1542

SS1843

SS2544

SS3044

REF: 19845	REF: 19846	REF:19850	REF: 19851	REF: 19852	REF: 19853
10 Tn	12 Tn	15 Tn	18 Tn	25 Tn	30 Tn
21 m ³	25 m ³	31 m ³	37 m ³	50 m ³	63 m ³
3080 mm	4080 mm	4080 mm	4080 mm	4080 mm	4500 mm
1000 mm	1000 mm	1100 mm	1100 mm	1100 mm	1200 mm
4000 mm	3100 mm	3600 mm	4100 mm	5100 mm	5200 mm
9000 Kg/h	9000 Kg/h	9000 Kg/h	9000 Kg/h	9000 Kg/h	9000 Kg/h

INCLUIDO HUSILLO EXTRACCIÓN HIELO Y TOLVA ADICIONAL. OPCIONAL: CONTROL ELECTRÓNICO DE LA VELOCIDAD Y DESCARGA.
 LOS SILOS ORBITALES REQUIEREN SER INSTALADOS DENTRO DE CÁMARAS FRIGORÍFICAS CON UNA TEMPERATURA INTERIOR DE ENTRE -3°C A -10°C, ASÍ COMO CON HUMEDAD CONSTANTE PARA EL CORRECTO ALMACENAMIENTO Y DISPENSADO DEL HIELO.
 SE RECOMIENDA ALMACENAR Y DISPENSAR HIELO FRESCO PRODUCIDO EL MISMO DÍA. SE DESACONSEJA ALMACENAR HIELO DURANTE MÁS DE 24H PARA EVITAR POSIBLE FORMACIÓN DE BLOQUES.

KITCHEN ICE

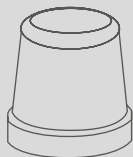

GALA
23/30cc

GOURMET ICE AT HOME

- Produces professional 22 grs ice cubes
- Daily ice production 10 kg
- 12 ice cubes every 38 minutes (nominal conditions)
- 8 kg stock inside
- Dynamic ice production: ice more transparent, no smell & no taste
- Reduce calcium carbonate percentage
- Dimensions for standard kitchen 60 cm width furniture
- Easy front & back ventilation

HIELO RECIÉN HECHO EN CASA

- Produce cubitos de hielo de 22 gr
- Producción diaria de hielo: 10 kg
- 12 cubitos de hielo cada 38 minutos
- Almacenaje de 8 kilogramos
- Producción de hielo dinámica: hielo más transparente, sin olor y sin gusto
- Reduce el porcentaje de carbonato de calcio
- Dimensiones para muebles de cocina estándar 60 cm anchura
- Fácil manejo y ventilación trasera





SPRAY SYSTEM
SISTEMA DE DUCHAS

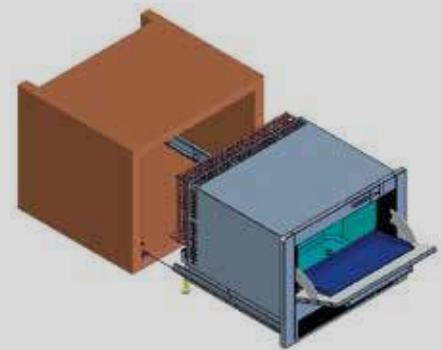
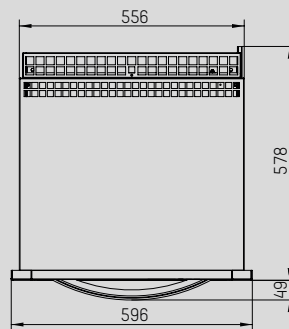
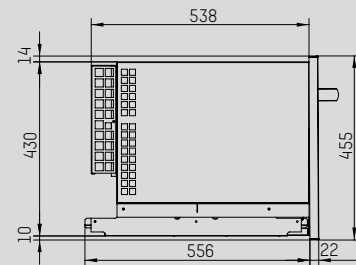
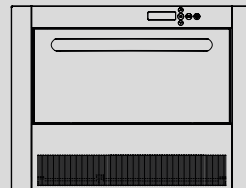

KITCHEN ICE

DIMENSIONS (mm)
(WxDxH)

596 x 578 x 455

	REF:13011
PRODUCTION 24H PRODUCCIÓN 24H	13 Kg.
STORAGE ALMACÉN	8 Kg. 364 cubes cubitos
CYCLE (CUBES) CICLO (CUBITOS)	12 cubes cubitos
COMPRESSOR COMPRESOR	1/5 CV
MAX. POWER INPUT POT. MÁX. ABSORBIDA	330 W
NET WEIGHT PESO NETO	40 Kg.



(1) PRODUCTION AT 20°C ROOM TEMPERATURE-15°C WATER TEMPERATURE. (2) MAXIMUM POWER ABSORBED IN CONDITIONS OF ROOM TEMPERATURE OF 43°C, ACCORDING TO THE RULES FOR CLASS T CLIMATIC CLASSIFICATION (TROPICALIZED). THE CONSUMPTION DECREASES AT LOWER ROOM TEMPERATURES.
(1) PRODUCCIÓN A 20°C TEMPERATURA AMBIENTE > 15°C TEMPERATURA AGUA (2) MÁXIMA POTENCIA ABSORBIDA EN CONDICIONES DE TEMPERATURA AMBIENTE DE 43°C, SEGÚN NORMAS PARA LA CLASIFICACIÓN CLIMÁTICA CLASE T (TROPICALIZADA). EL CONSUMO DISMINUYE EN TEMPERATURAS AMBIENTE INFERIORES.

SIRION DHD

SIRION DHD DISPENSER | SIRION DHD DISPENSER 130 SLIM

A STAINLESS STEEL BUTLER

SIRION Ice Dispenser is the optimal solution if you want to be sure that you have ice at all times in order to provide the desired level of comfort and build up customer loyalty. It is easy to use, silent and efficient, just like having a personal butler to serve your clients. ITV's new ice dispenser produces large and small ice cubes. Ice is easily released just with a light push, always meeting the needs of your clients. The 30" model stores up to 104 kg of ice and it features a convenient access to the tub, enabling easy cleaning without having to move the ice machine.

The machine is supplied with AISI 304 stainless steel case and adjustable legs. It also features built-in lightening and a 20-sm sink depth, so it can be installed in any hotel-size cooler. This machine is reliable, hygienic, with only a few parts, energy-efficient and it has a modern and attractive appearance. It meets EC and NSF regulations and certifications. ITV ice maker is available with water refill and a coin mechanism. It is a perfect choice for hotels, resorts and recreation centres

UN MAYORDOMO DE ACERO INOXIDABLE

El Dispensador de hielo SIRION es la mejor solución si usted quiere estar seguro de tener hielo en cualquier momento, para proporcionar el confort deseado y para fidelizar al cliente. Fácil de usar, silencioso y eficiente, es como tener un mayordomo a disposición de sus clientes. El nuevo Dispensador de hielo de ITV dispensa cubitos de dado y medio dado. Su simple empuje para dispensar hielo fácilmente siempre cumplirá con los requisitos de sus clientes. El modelo de 30" almacena hasta 104 kilos y permite un acceso cómodo a la cuba para una fácil limpieza sin tener que quitar la máquina de hielo.

Viene con una carcasa de acero inoxidable AISI 304 y patas ajustables. La iluminación está incorporada y la profundidad de fregadero de 20 cm. permite colocar cualquier cubitera de tamaño hotel. Fiable, higiénico, pocos número de piezas, eficiencia de energía de ahorro con un aspecto moderno y atractivo. Cumple con la reglamentación y certificación de NSF y CE. Disponible con relleno de agua y el mecanismo de la moneda, el Dispensador de hielo ITV es ideal para hoteles, resorts y centros de ocio.

OPTION BUILT-IN WATER PUSH UP OPCIÓN FUENTE DE AGUA

DHD200-30W 115/60 | DHD 200-30W 220/50

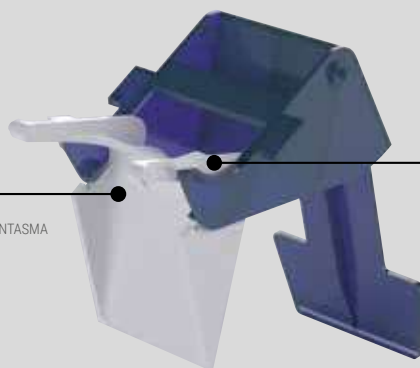

ANTI-FREEZE SYSTEM
TRINQUETE ANTI-HIELO FANTASMA

ROCKING DISPENSING MECHANISM
EMPUJADOR APERTURA COMPUERTA

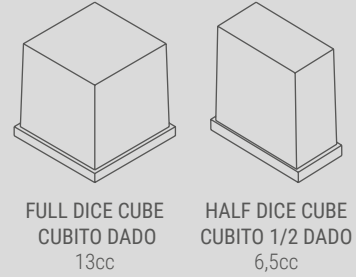

DISPENSER DHD 200

DIMENSIONS (mm)
(WxDxH)

769 x 835 x 1383/1536*
*WITH EXTRA FEET CON PATAS



DISPENSER DHD 130 SLIM

559 x 835 x 1218/1371*
*WITH EXTRA FEET CON PATAS



	ICE DISP. DISP. HIELO	ICE AND WATER DISP. DISP. HIELO Y AGUA	ICE DISP. DISP. HIELO	ICE AND WATER DISP. DISP. HIELO Y AGUA
	REF:19300	REF:19301	REF:19321	REF:19329
STORAGE ALMACÉN	104 Kg.		58 Kg.	
DISP. SPEED VEL. DISPENSADOR	109 g/s		109 g/s	
VOLTAGE VOLTAJE	220V/50Hz		220V/50Hz	

CASES VITRINAS

SUSHI CASE 145/180 | CASE 1L 110/145/175 | CASE 2L 110/145/175

REFRIGERATED CASES

ITV cases are designed to preserve food under optimal conditions placed on counter tops. Having a great attractive design

FEATURES

- Anodized aluminium external strip, available in black or silver.
- Independent access to condensing unit without touching food space
- Curved tempered safety glass. It can be lifted and/or remove for cleaning
- EASYCLEAN TRAYS SYSTEM®, in stainless steel without drains, which are not usually hygienic
- GN 1/3 x 40mm trays included inside all tray models
- Led lighting
- Available 220V/50hz, 115V/60hz
- Sliding smoked doors
- Automatic defrost programmable time (except SUSHI CASE)

SUSHI CASE ADDITIONAL FEATURES

- Double evaporator (upper and lower) to keep the exact desired temperature
- Keeps humidity and temperature levels without air circulation to avoid drying out the fish
- ZERO CONDENSATION SYSTEM® inside case when running cause compressor never stops
- No defrost required
- Reach nominal low temperature +1°C/-1°C in a few minutes from the moment it's switched on
- ANTIBACTERIAL EVAPORATOR SYSTEM DESIGN®, Design of an evaporator system made by tubes that prevents the nesting of bacteria, avoiding the use of not hygienic fin systems
- Ambient temperature display for full control
- External aluminum finishes available in black or silver

VITRINAS REFRIGERADAS

Las vitrinas ITV estan diseñadas para proteger la comida expuesta bajo condiciones óptimas sobre mostrador con un atractivo diseño

CARACTERÍSTICAS

- Acabados externos en aluminio anodizado, disponibles en negro y plata.
- Acceso independiente a la unidad condensadora sin tocar el espacio donde se encuentra la comida expuesta
- Cristal curvo de seguridad, templado, de fácil extracción y limpieza
- EASYCLEAN TRAYS SYSTEM®, Sistema de bandejas de fácil limpieza, sin drenajes, que no suelen resultar higiénicos
- Bandejas GN 1/3 x 40mm incluidas dentro de todos los modelos de bandejas
- Iluminación mediante LED
- Disponible en 220V/50hz, 115V/60hz
- Puertas deslizantes en cristal ahumado
- Eliminación automática de escarcha cada cierto tiempo ajustable (excepto la vitrina de SUSHI)

CARACTERÍSTICAS ADICIONALES VITRINA SUSHI

- Doble evaporador (superior e inferior) para mantener la temperatura exacta deseada dentro de la vitrina
- Mantiene la humedad y temperatura sin circulación de aire para evitar el secado del pescado
- ZERO CONDENSATION SYSTEM®, Sistema de condensación cero dentro de la vitrina mientras está conectada
- No es necesaria la eliminación de escarcha
- Alcanza en unos minutos la temperatura nominal +1°C/-1°C desde que se conecta
- ANTIBACTERIAL EVAPORATOR SYSTEM DESIGN®, diseño de un sistema de evaporador que evita la anidación de bacterias, realizado mediante tubos sin emplear sistemas de aletas poco higiénicos
- Acabados externos en aluminio disponibles en negro o plata.



CASES VITRINAS

SUSHI CASE 145/180 | CASE 1L 110/145/175 | CASE 2L 110/145/175

DIMENSIONS (mm)
(WxDxH)

SUSHI 145/180
1447/1797* x 387 x 240
*SUSHI 180

110 1L 4T/4P
1092 x 387 x 240

145 1L 6T/6P
1447 x 387 x 240

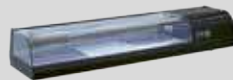

	SUSHI 145	SUSHI 180	110 1L 4T	110 1L 4P	145 1L 6T	145 1L 6P
	BLACK-REF: 22001 SILVER-REF: 22000	BLACK-REF: 22002 SILVER-REF: 22003	BLACK-REF: 22100 SILVER-REF: 22101	BLACK-REF: 22103 SILVER-REF: 22104	BLACK-REF: 22106 SILVER-REF: 22107	BLACK-REF: 22109 SILVER-REF: 22110
STORAGE VOLUME* CAPACIDAD	11,7 L.	15,6 L.	7,7 L.		11,7 L.	
LEVELS NIVELES	1		1		1	
NUMBER TRAYS NÚMERO BANDEJAS	-	-	4	-	6	-
PLATES CAPACITY CAPACIDAD PLATOS	6	8	-	4	-	6
POWER POTENCIA	0,13 Kw		0,13 Kw		0,13 Kw	
COMPRESSOR COMPRESOR	1/6 hp		1/6 hp		1/6 hp	
FOOD ZONE T° AT 32°C AMBIENT	-1°C / +1°C		+4°C / +8°C		+4°C / +8°C	
DISPLAY SURFACE SUPERFICIE DIPONIBLE	0,37 m2	0,47 m2	0,27 m2		0,37 m2	
NET/GROSS WEIGHT PESO NETO	39/49 Kg.	37/52 Kg.	28/40 Kg.		35/45 Kg.	

175 1L 8T/8P
1797 x 387 x 240

110 2L 4T/4P
1092 x 387 x 360

145 2L 6T/6P
1447 x 387 x 360

175 2L 8T/8P
1797 x 387 x 360



175 1L 8T		175 1L 8P		110 2L 4T		110 2L 4P		145 2L 6T		145 2L 6P		175 2L 8T		175 2L 8P	
BLACK-REF: 22112 SILVER-REF: 22113		BLACK-REF: 22115 SILVER-REF: 22116		BLACK-REF: 22200 SILVER-REF: 22201		BLACK-REF: 22203 SILVER-REF: 22204		BLACK-REF: 22206 SILVER-REF: 22207		BLACK-REF: 22209 SILVER-REF: 22210		BLACK-REF: 22212 SILVER-REF: 22213		BLACK-REF: 22215 SILVER-REF: 22216	
15,6 L.				7,7 L.				11,7 L.				15,6 L.			
1				2				2				2			
8	-	-	-	4	-	-	-	6	-	-	-	8	-	-	-
-	8	-	-	-	4	-	-	-	6	-	-	-	8	-	-
0,13 Kw				0,13 Kw				0,13 Kw				0,13 Kw			
1/6 hp				1/6 hp				1/6 hp				1/6 hp			
+4°C / +8°C				+4°C / +8°C				+4°C / +8°C				+4°C / +8°C			
0,47 m2				0,27 m2				0,37 m2				0,47 m2			
38/53 Kg.				38/50 Kg.				43/55 Kg.				48/62 Kg.			

WATER COOLERS

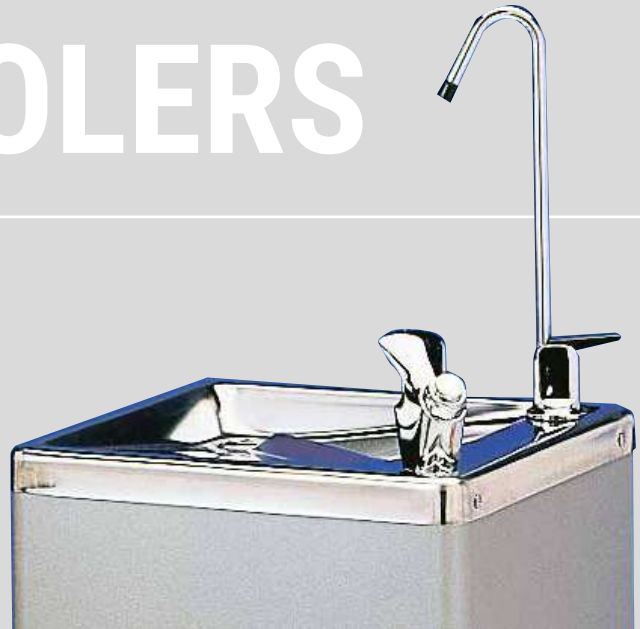

THE IDEAL WATER COOLER
FOR EACH ENVIRONMENT
THANKS TO ITS FLEXIBILITY:
OFFICES, WAITING ROOMS,
PUBLIC SPACES...

RA 5 INOX

Suitable for public areas and waiting rooms. Schools and shopping centers, offices...

It connects very easily to the mains and always offers fresh water. The refrigeration technology by direct exchange guarantees consistent and lasting quality with very little need for maintenance. Available in three versions,

RA 5 INOX. It has a push-button to drink directly.

RA 5G INOX has a push-button to drink directly and a tap to fill jugs.

RA 5G INOX PEDAL has a push-button to drink directly, a tap to fill pitchers and a pedal.

Finished in stainless steel.

RA 5G INOX UP It has a button to drink directly. To be anchored to the wall (without foot).

Available in these versions: only cold water

RAB 20

These water coolers give great flexibility because it doesn't need connection to the water network: offices, waiting rooms, public spaces...

It is the typical water cooler that is simple and at the same time efficient. It supplies cold water through tank technology. Compatible with the majority of bottles on the market. Its "Hygienic System" prevents contamination by filtering the air inlet in the bottle, it makes placement easier and prevents water loss.

Supplied with a bottle.

Supplied with bottle.

Available in these versions: cold water, cold/hot water.

RAC 20

Commonly used for: meeting rooms, offices, stores, businesses, and institutions. Mains fed, combines an innovative yet functional design with the latest technologies in hygiene and water refrigeration. Has a built-in system that stores and dispenses cups. Mugs and small bottles, aside from regular cups, can be filled. New design with backlit buttons.

Available in these versions: cold water, cold/hot water.

RAIN 120 INOX

These water coolers are ideal for communities and school cafeterias, military kitchens, hotel buffets, etc...

Available in two versions to facilitate positioning in confined spaces:

RAIN 120 INOX on a column.

RAIN 120 TOP INOX on the counter.

The ice bank system manages to cool a larger quantity of water and maintain a constant temperature.

Finished in stainless steel.

Available in these versions: cold water, cold water with gas and antibacterial system.

OFFICE

Perfect for small offices, professional studios, cafés, small restaurants and homes.

Compact and functional, it is directly connected to the mains to provide plenty of cold water or water at room temperature. The absence of taps protects the water from external contamination. The control panel has two push-buttons, one for each type of water. The refrigeration technology with ice bank allows you to obtain high output in a small space.

Available in these versions: cold water, cold/hot water.

FUENTES DE AGUA

**PROPORCIONA AGUA FRÍA
EN RESTAURANTES, OFICINAS,
COLECTIVIDADES, INDUSTRIAS,
HOSPITALES...**

RA 5 INOX

Indicada para ambientes y áreas públicas, salas de espera, escuelas y centros comerciales, oficinas...

Se conecta muy fácilmente a la red de suministro y ofrece agua siempre fresca. La tecnología de refrigeración por intercambio directo garantiza calidad constante y duradera con escasa necesidad de mantenimiento. Disponible en tres versiones:

RA 5 INOX Dispone de pulsador para beber directamente.

RA 5G INOX Dispone de pulsador para beber directamente y de grifo para el llenado de jarras.

RA 5G INOX PEDAL Dispone de pulsador para beber directamente, grifo para el llenado de jarras y pedal. Acabado en acero inoxidable.

RA 5G INOX UP Dispone de pulsador para beber directamente. Para anclar a la pared (sin pie).

Disponibles en la versión: solo en agua fría.

RAB 20

La fuente ideal sin necesidad de conexión a red de agua que le confiere gran flexibilidad: oficinas, salas de espera, espacios públicos...

RAB 20 es la típica fuente de agua simple y a la vez eficiente. Suministra agua fría mediante la tecnología de depósito. Compatible con la mayoría de los botellones del mercado. Su "Hygienic System" evita contaminaciones filtrando la entrada de aire en la botella, facilita la colocación de la misma e impide las pérdidas de agua.

Se suministra con botellón.

Disponibles en las versiones: agua natural/fría y agua fría/caliente.

RAC 20

Comunes en: lugares de reunión, oficinas, tiendas y comercios e instituciones. Conectada a la red combina un diseño innovador y funcional con las tecnologías más avanzadas en materia de higiene y refrigeración del agua. Incorpora un sistema interno que almacena y dispensa vasos. Nuevo diseño con pulsadores retroiluminados.

Disponibles en las versiones: agua natural/fría y agua natural/fría/caliente.



RAIN 120 INOX

Estas fuentes son ideales para colectividades, comedores de escuelas, comedores del ejército, buffets de hoteles, etc... Disponible en dos versiones para facilitar el posicionamiento de espacios reducidos:

RAIN 120 INOX de columna.

RAIN 120 TOP INOX de mostrador.

El sistema de banco de hielo consigue enfriar una cantidad mayor de agua y mantener constante la temperatura.

Acabado en acero inoxidable.

Versión de agua natural/fría, agua natural/fría/con gas y agua natural/fría/con gas y sistema antibacteriano.

OFFICE

Perfecta para pequeñas oficinas, estudios profesionales, cafeterías, pequeños restaurantes y el hogar.

Compacta y funcional, se conecta directamente a la red para suministrar abundante agua fría o a temperatura ambiente. La ausencia de grifos protege el recorrido del agua de contaminaciones externas. El panel de control dispone de tres pulsadores, uno para cada tipo de agua. La tecnología de refrigeración con banco de hielo permite obtener altas prestaciones en poco espacio.

Disponibles en las versiones: agua natural/fría y agua natural/fría/caliente.

WATER COOLERS

OFFICE | RAB20 | RA5 INOX | RA5 INOX UP | RA5G INOX | RAC20 | RAIN 120 INOX | RAIN120 TOP

DIMENSIONS (mm)
(LxPxA)

OFFICE
260 x 330 x 407
BASE TO 60mm
HEIGHT DISP. AREA 230mm

**OFFICE
COLD & HOT WATER**
260 x 330 x 407
BASE TO 60mm
HEIGHT DISP. AREA 230mm

RAC 20
334 x 330 x 1120
BASE TO 700mm
HEIGHT DISP. AREA 256mm

**RAC 20
COLD & HOT
WATER**
334 x 330 x 1120
BASE TO 700mm
HEIGHT DISP. AREA 256mm



	REF: 9885	REF: 9884	REF:	REF:
PRODUCTION PRODUCCIÓN	15 L/h (COLD FRÍA)	15 L/h (COLD FRÍA) 13 L/h (HOT CALIENTE)	20 L/h (HOT CALIENTE)	20 L/h (COLD FRÍA) 8 L/h (HOT CALIENTE)
COMPRESSOR COMPRESOR	1/12 CV	1/12 CV	1/10 CV	1/10 CV
ABS ABS	190 W	1390 W	150 W	850 W
NET WEIGHT PESO NETO	14 Kg.	15 Kg.	21 Kg.	22 Kg.

RAC 20 - OPTIONAL WITH UV ANTI-BACTERIAL SYSTEM RAC 20 - OPCIONAL CON SISTEMA ANTIBACTERIANO MEDIANTE LUZ ULTRAVIOLETA

FUENTES DE AGUA



RAB 20

340 x 347 x 1103/1600

BASE TO 590mm

HEIGHT DISP. AREA 256mm

RAB 20 COLD & HOT WATER

340 x 347 x 1103/1600

BASE TO 590mm

HEIGHT DISP. AREA 256mm

RA5

340 x 325 x 960

+80mm INCLUDING TAP

RA5G

340 x 325 x 960

+270mm INCLUDING TAP



REF: 9886	REF: 9057	REF: 9055	REF: 9056
22 L/h (COLD FRÍA)	22 L/h (COLD FRÍA) 5 L/h (HOT CALIENTE)	30 L/h (COLD FRÍA)	30 L/h (COLD FRÍA)
1/12 CV	1/12 CV	1/10 CV	1/10 CV
110 W	560 W	180 W	180 W
18 Kg.	19 Kg.	26 Kg.	26 Kg.

RAB 20 - OPTIONAL CUP DISPENSER RAB20 OPCIONAL PORTA-COPOS

WATER COOLERS

OFFICE | RAB20 | RA5 INOX | RA5 INOX UP | RA5G INOX | RAC20 | RAIN 120 INOX | RAIN120 TOP

DIMENSIONS (mm)
(LxPxA)

RA5GP

340 x 325 x 960
+270mm INCLUDING TAP

RA5 UP

432 x 360 x 505
+80mm INCLUDING TAP

RAIN 120 INOX

480 x 405 x 1480
BASE TO 985mm
HEIGHT DISP. AREA 311mm

RAIN 120 INOX GAS

480 x 560 x 1480
BASE TO 985mm
HEIGHT DISP. AREA 311mm



	REF: 9199	REF: 9883	REF: 9444	REF: 19007
PRODUCTION PRODUCCIÓN	30 L/h (FRÍA FRÍA)	30 L/h (COLD FRÍA)	120 L/h (COLD FRÍA)	120 L/h (COLD/SPARKLING FRÍA/GAS)
COMPRESSOR COMPRESOR	1/10 CV	1/10 CV	1/3 CV	1/3 CV
ABS ABS	180 W	180 W	680 W	900 W
NET WEIGHT PESO NETO	26 Kg.	26 Kg.	45 Kg.	53 Kg.

FUENTES DE AGUA

RAIN 120 INOX GAS ANTIBAC.

480 x 560 x 1480

BASE T O 985mm
HEIGHT DISP. AREA 311mm



RAIN TOP 120 INOX

482 x 495 x 510

BASE TO 15mm APROX
HEIGHT DISP. AREA 346mm



RAIN TOP 120 INOX GAS

482 x 495 x 510

BASE TO 15mm APROX
HEIGHT DISP. AREA 346mm



RAIN TOP 120 INOX GAS ANTIBAC.

482 x 495 x 510

BASE TO 15mm APROX
HEIGHT DISP. AREA 346mm



REF: 19009	REF: 9189	REF:	REF: 19010
120 L/h (COLD/SPARKLING FRÍA/GAS)	120 L/h (COLD FRÍA)	120 L/h (FRÍA/GAS FRÍA/GAS)	120 L/h (COLD/SPARKLING FRÍA/GAS)
1/3 CV	1/3 CV	1/3 CV	1/3 CV
900 W	750 W	1000 W	1000 W
53 Kg.	39 Kg.	50 Kg.	50 Kg.

ICE CRUSHER

TR3 INOX | TR5 INOX

TR INOX

Increasingly, crushed ice is being used more frequently in gastronomy, for beverage and cocktail preparation and for food presentation.

The ITV ice crusher needs little space and rapidly transforms ice cubes into perfectly crushed ice.

Thanks to the ice crushers' crushing mechanism ITV's TR3 INOX, both the necessary force and the energy consumption is reduced. The stainless steel box facilitates cleaning and guarantee hygiene.

With 3 and 5 Kg of nominal capacity, the ITV range with the TR3 and TR5 covers all of the needs of any establishment in the hospitality sector.

It crushes ice cubes up to of 25gr: Gala, Alfa, Quasar and Spika cubes

TR INOX

En la gastronomía se utiliza cada vez más el hielo triturado para la preparación de bebidas y cocktails y para la presentación de alimentos.

Las trituradoras de hielo ITV necesitan poco espacio y transforman en segundos los cubitos de hielo perfectamente triturado.

Gracias al mecanismo triturador de la trituradora TR3 INOX de ITV, tanto la fuerza necesitada como el consumo de energía es reducido. La caja, de acero inoxidable facilita la limpieza y garantiza la higiene.

TR INOX es el triturador más robusto y por tanto de mayor vida útil del mercado, gracias a su carácter industrial y sus componentes de primera calidad.

De 3 y 5 Kg. de capacidad nominal, la gama ITV con el TR3 y TR5 cubre las necesidades de cualquier local de hostelería. Tritura cubitos de hielo hasta un tamaño de 25gr: cubitos Gala, Alfa, Quasar y Spika.





TR3 INOX

180 x 330 x 320

TR5 INOX

370 x 310 x 510

DIMENSIONS
(WxDxH)



	REF: 9148	REF: 9803
CAPACITY CAPACIDAD	3 Kg./min.	5 Kg./min.
STORAGE DEPÓSITO	1 Kg.	5 Kg.
CONSUMPTION CONSUMO	0,15 kW	0,15 kW
NET WEIGHT PESO NETO	10 Kg.	20 Kg.

FROSTY

F2

FROSTY CREAM WHIPPING MACHINE

Small, easy to use, elegant, revolutionary thanks to the technical solutions adopted; these are some of the characteristics of the new FROSTY cream whipping machines.

They comply with the current regulations, facilitating cleaning and maintaining hygiene at all times.

They produce high-quality whipped cream, with a considerable increase in volume, and a firm and stable structure that gives a touch of distinction to all types of food.

F2 FROSTY CREAM WHIPPING MACHINE

Refrigerated by means of a refrigerant circuit with a 1/8 CV compressor.

It continuously maintains the temperature of the cream at 4°C.

2-liter detachable liquid cream tank.

The transparent upper cover allows the remaining level of cream in the tank to be seen at all times.

Whipped cream production of 100 liters/hour.

Single-piece labyrinth.

Electric pump motor.

MONTADORAS DE NATA PARA LA RESTAURACIÓN

Pequeñas, sencillas de manejar, de línea elegante, revolucionarias por las soluciones técnicas adoptadas, son algunas de las características de las nuevas montadoras de nata FROSTY.

Cumplen con la normativa en vigor, facilitando la limpieza y manteniendo la higiene en todo momento.

Producen nata montada de alta calidad, con un considerable aumento de volumen, estructura firme y estable para dar un toque de distinción sobre toda clase de alimentos.

Para montar las natas más habituales del mercado, con un contenido en grasa del 30%. Para natas con otros contenidos en grasa, consultar.

MONTADORA NATA FROSTY F2

Refrigerada mediante un circuito frigorífico con un compresor de 1/8 CV. Mantiene la temperatura de la nata líquida a 4°C de manera continua.

Depósito extraíble de 2 litros para nata líquida.

La tapa transparente superior permite visualizar en todo momento el nivel de nata líquida que queda en el depósito.

Producción de 100 litros / hora de nata montada.

Laberinto de una sola pieza.

Motor eléctrico de la bomba.





F-2

DIMENSIONS (mm)
(WxDxH)

250 x 410 x 400

	REF: 9051
PRODUCTION 1H PRODUCCIÓN 1H	100
CAPACITY CAPACIDAD	2
PUMP BOMBA	0,27 Kw
COMPRESSOR COMPRESOR	1/8 CV

FILTRATION

FILTRATION SYSTEMS

The quality of the water directly affects the lifespan of these machines, as well as the quality of ice that is obtained with ITV machines.

ITV provides filtration equipment that protects the ice machines ensuring proper functioning and extending lifespan. Installation is essential so that the machines will last for many years.

Do accompany the best machine on the market with your filter suitable.. The annual cost is minimal, you only need to change the cartridge once a year, depending on the hardness of the water and following the recommendations of ITV and the result achieved is excellent: a machine in good conditions for many years.

PARTICLE FILTER

To filter waste water or sandy water.

Mechanical filter for particles of 5 microns made of woven polypropylene. Prevents the entry of dirt into the machine while protecting valves, pumps, evaporator, etc.

ANTI-CHLORINE FILTER

To remove the bad taste and smell from the water, in addition to filtering waste water or sandy water. Suitable for water with bad odors and flavors or for water that is highly chlorinated. Active charcoal filter and particles of 5 microns. The filter absorbs the particles of unpleasant odors and flavors.

CS ANTI-LIMESCALE AND ANTI-CHLORINE FILTER

To protect against water with a high content of limescale and to remove the bad taste and odor from the water. Suitable for water with a lot of limescale and with bad odors and flavors or for water that is highly chlorinated.

Anti-limescale active charcoal filter. The filter protects against limescale, it absorbs the chlorinated particles as well as unpleasant odors and flavors. Available in single or double version and in normal size or XL, depending on the type of machine that it is going to protect.

INSURICE FILTER

This is the most complete filter of the range, to reduce bacterial contaminants, protect against water with high limescale

content, and remove the bad taste and smell from the water by filtering microscopic particles. Suitable for extreme conditions, water with a lot of limescale, or with bad odors and flavors, wherever a healthy level of quality is sought.

AglON™ antibacterial, limescale filter, activated charcoal and 0.5 micron particle filter. The filter reduces contaminants such as asbestos, bacterial cysts, it protects against limescale, it absorbs chlorinated particles as well as unpleasant odors and flavors.

- The capacity of the filter and the lifespan of the cartridge depend on the quality of the water.
- See the correspondence tables by contacting with the SAT of ITV.

WATER SOFTENERS

It is ideal for hospitality applications since it is compact and fast in regeneration. Volumetric water softener with resin. To fill it up with salt (NaCl). Suitable for water with high limescale content, up to 50-60 degrees of hardness.

REPLACEMENT FILTERS

ANTI-LIMESCALE and ANTI-CHLORINE cartridges and INSURICE are renewed by replacement of what is used up on the existing head. The PARTICLE and ANTI-CHLORINE cartridges are replaced by emptying the glass container and removing the used cartridge.

As a reference, the cartridges have a useful lifespan of 1 year. Calculation estimated for an average ice machine with a level of average hardness of water. The replacement of the glass container is supplied in alimentary opaque polypropylene of 9" or 10" with support and coupling for connection to 3/4".

CALKLIN

Product to carry out the periodic cleaning of the ice machines.

They are envelopes with citric acid as the active component that eliminates the limescale deposited in the entire circuit of the ice machines, evaporator, storage, etc. It can also be used for the cleaning of coffee machines, dishwashers, kettles, vending machines, etc... CALKLIN does not stain, is non-corrosive, it can be transported and it can be rinsed down the drain. It is presented in envelopes containing bags of 50gr for machines with production of up to 60Kg./24h or in bags of 200GR for machines with larger daily production.

FILTRACIÓN

SISTEMAS DE FILTRACIÓN

La calidad del agua afecta directamente a la vida útil de las máquinas, así como a la calidad del hielo que se obtiene con los fabricantes de ITV.

ITV suministra equipos de filtración que protegen las máquinas de hielo asegurando un correcto funcionamiento de las mismas y alargando su vida útil. Es fundamental su instalación para que las máquinas perduren por muchos años.

Acompañe a la mejor máquina del mercado con su filtro adecuado. El coste anual es mínimo, sólo cambiar el cartucho una vez al año, dependiendo de la dureza del agua y siguiendo las recomendaciones de ITV y el resultado logrado es máximo: máquina en buenas condiciones para muchos años.

FILTRO ANTICAL

Para proteger contra aguas con alto contenido en cal, eliminar el mal sabor y olor del agua. Incorpora un filtro mecánico para partículas superiores a 20 micras.

FILTRO PARTÍCULAS

Para filtrar aguas sucias o arenosas.

Filtro mecánico para partículas de polipropileno tejido 5 micras. Evita la entrada de suciedad en la máquina protegiendo válvulas, bombas, evaporador, etc.

FILTRO ANTICLORO

Para eliminar el mal sabor y olor del agua, además de filtrar aguas sucias o arenosas. Indicado para agua con malos olores y sabores o muy cloradas. Filtro de carbón activo y partículas de 5 micras. El filtro absorbe las partículas de olores y sabores desagradables.

FILTRO CS ANTICAL Y ANTICLORO

Para proteger contra aguas con alto contenido en cal, eliminar el mal sabor y olor del agua. Indicado para agua con mucha cal y con malos olores y sabores o muy cloradas.

Filtro antical, de carbón activo. El filtro protege contra la cal, absorbe las partículas cloradas así como olores y sabores desagradables. Disponible en su versión simple o doble y en tamaño normal o XL, en función del tipo de máquina que vaya a proteger.

Incorpora un filtro mecánico para partículas superiores a 5 micras.

FILTRO INSURICE

Es el filtro más completo de la gama: para reducir contaminantes bacterianos, proteger contra aguas con alto contenido en cal, eliminar el mal sabor y olor del agua filtrando partículas microscópicas. Indicado condiciones extremas, aguas con mucha cal, con malos olores y sabores donde se busque un elevado nivel de calidad sanitaria.

Filtro antibacteriano AgIONTM, antical, de carbón activo y partículas de 0,5 micras. El filtro reduce contaminantes como el amianto, quistes bacterianos, protege contra la cal, absorbe las partículas cloradas así como olores y sabores desagradables.

- La capacidad del filtro y la vida útil del cartucho dependen de la calidad del agua.
- Consulte las tablas de correspondencia contactando con el SAT de ITV.

DESCALCIFICADOR EURO C4

Es ideal para aplicaciones de hostelería al ser compacto y rápido en la regeneración. Descalcificador cronométrico de sal con 3.5l de resina. Indicado para aguas con alto contenido en cal, hasta 50-60 grados de dureza.

RECAMBIOS FILTROS











Los cartuchos ANTICAL y ANTICLORO e INSURICE se reemplazan por sustitución del gastado en el cabezal existente. Los cartuchos Partículas y ANTICLORO se reemplazan vaciando el vaso contenedor y sacando el cartucho gastado. De manera orientativa, los cartuchos tienen una vida útil de 1 año. Cálculo estimado para una máquina de hielo media con un nivel de dureza de agua medio. El recambio del vaso contenedor se suministra en polipropileno alimentario opaco de 9" ó 10" con soporte y racord para conexión a 3/4".

CALKLIN

Producto para realizar la limpieza periódica de las máquinas de hielo. Se presenta en sobres contenidos en bolsas de 50gr para máquinas con producción de hasta 60kg/24h. o en bolsas de 200gr. para máquinas con mayores producciones diarias.

FILTRACIÓN

FEATURES / CARACTERÍSTICAS

	REF:	FUNCTIONING FUNCIONAMIENTO	MICRONS/MICRAS	INDICATED TO INDICADO PARA
ANTI-LIMESCALE FILTER	 7500	ANTI LIMESCALE/ACTIVE COAL/PARTICLES ANTICAL/CARBÓN ACTIVO/PARTÍCULAS	20	ALL ICE MACHINES TODAS LAS MÁQUINAS DE HIELO
PARTICLE FILTER	 7499	MECHANICAL/POLIPROPILENO FIBER/TISSUE MECÁNICO/FIBRAS POLIPROPILENO/TEJIDO	5	ALL ICE MACHINES TODAS LAS MÁQUINAS DE HIELO
ANTI-CHLORINE FILTER	 7509	ACTIVE COAL CARBÓN ACTIVO	5	ICE MACHINES UP TO 120KG./24H.+WATER COOLERS MÁQ. CUBITOS HASTA 120KG./24H.+FUENTES
ANTI-LIMESCALE & ANTI-CHLORINE FILTER CS101	 6759	ANTI LIMESCALE/ACTIVE COAL/PARTICLES ANTICAL/CARBÓN ACTIVO/PARTÍCULAS	5	ICE MACHINES UP TO 120KG./24H.+ALL IQ MACHINES MÁQ. CUBITOS HASTA 120KG./24H.+TODAS IQ
ANTI-LIMESCALE & ANTI-CHLORINE FILTER XL CS111	 6830	ANTI LIMESCALE/ACTIVE COAL/PARTICLES ANTICAL/CARBÓN ACTIVO/PARTÍCULAS	5	ICE MACHINES FROM 120 TO 215KG./24H. MÁQ. CUBITOS ENTRE 120 Y 215KG./24H.
ANTI-LIMESCALE & ANTI-CHLORINE FILTER TWIN CS102	 6760	ANTI LIMESCALE/ACTIVE COAL/PARTICLES ANTICAL/CARBÓN ACTIVO/PARTÍCULAS	5	ICE MACHINES FROM 215 TO 340KG./24H. MÁQ. CUBITOS ENTRE 215 Y 340KG./24H.
ANTI-LIMESCALE & ANTI-CHLORINE FILTER XL TWIN CS112	 6987	ANTI LIMESCALE/ACTIVE COAL/PARTICLES ANTICAL/CARBÓN ACTIVO/PARTÍCULAS	5	ICE MACHINES FROM 340KG./24H. MÁQ. CUBITOS MÁS DE 340KG./24H.
INSURICE FILTER WITH SHUT-OFF VALVE AND GAUGE	 7369	ANTI LIMESCALE/PARTICLES/ACTIVE COAL ANTICAL/CARBÓN ACTIVO/PARTÍCULAS	0,5	ICE MACHINES OVER 340KG./24H. MÁQUINAS CUBITOS MÁS DE 340KG./24H.
FILTRO INSURICE SIN MANÓMETRO	 7603	ANTI LIMESCALE/PARTICLES/ACTIVE COAL ANTICAL/CARBÓN ACTIVO/PARTÍCULAS	0,5	ICE MACHINES OVER 340KG./24H. MÁQUINAS CUBOS MAIS DE 340KG./24H
C4 WATER SOFTENER	 30353	VOLUMETRIC/SALT/3,5L. RESIN ICE VOLUMÉTRICO/SAL/3,5L. RESINA		MACHINES UP TO 140KG./24H. MÁQUINAS HIELO HASTA 140KG./24H.
C10 WATER SOFTENER	 30500	VOLUMETRIC/SALT/10L. RESIN VOLUMÉTRICO/SAL/10L.		ICE MACHINES FROM 150KG./24H. RESINA MÁQUINAS HIELO DESDE 150KG./24H.

REPLACEMENTS

FEATURES | CARACTERÍSTICAS

REF:



ANTI-LIMESCALE CARTRIDGE CARTUCHO ANTICAL	1041
PARTICLES CARTRIDGE I CARTUCHO PARTÍCULAS	1045
ANTI-CHLORINE CARTRIDGE I CARTUCHO ANTICLORO	769
ANTI-LIMESTONE & ANTI-CHLORINE CARTRIDGE CS10 I CARTUCHO ANTICAL+ANTICLORO CS10	6723
ANTI-LIMESTONE & ANTI-CHLORINE CARTRIDGE XL CS11 I CARTUCHO ANTICAL+ANTICLORO XL CS11	6724
INSURICE CARTRIDGE I CARTUCHO INSURICE	4031
FILTER HOUSING I VASO CONTENEDOR	838

ITV RECOMMENDS | ITV RECOMIENDA

IN INSTALLATIONS WHERE THERE IS A WATER SUPPLY WITH A HIGH CONTENT OF LIMESCALE, WE RECOMMEND THE INSTALLATION OF A WATER SOFTENER OR OSMOSIS TREATMENT, IN ORDER TO MAKE THE ICE MORE CLEAR AND LENGTHEN THE LIFETIME OF YOUR ICE MACHINE. SEE THE MACHINE MANUAL OR CONTACT OUR TECHNICAL SUPPORT SERVICE (SAT) | e-mail:service@itv.es TO CALCULATE THE FLOW OF WATER NEEDED. EN INSTALACIONES DONDE HAYA SUMINISTRO DE AGUA CON ALTO CONTENIDO EN CAL RECOMENDAMOS LA INSTALACIÓN DE UN DESCALCIFICADOR O TRATAMIENTO DE ÓSMOSIS, CON OBJETO DE CONSEGUIR SUS HIELOS MAS TRANSPARENTES Y ALARGAR LA DURACIÓN DE SU MÁQUINA DE HIELO. CONSULTE EL MANUAL DE LA MÁQUINA O A NUESTRO SERVICIO DE ASISTENCIA TÉCNICA | e-mail:service@itv.es PARA CALCULAR EL CAUDAL DE AGUA NECESARIA.

CLEANING

FEATURES | CARACTERÍSTICAS

	REF:	FUNCIONAMIENTO	INDICATED TO I INDICADO EN
 CALKLIN 50	1420	ICE MACHINES ANNUAL CLEANING LIMPIEZA ANUAL MÁQUINAS HIELO	ALL ICE MACHINES UP TO 60KG./24H. TODAS MÁQUINAS HIELO HASTA 60KG./24H.
 CALKLIN 200	4033	ICE MACHINES ANNUAL CLEANING LIMPIEZA ANUAL MÁQUINAS HIELO	ALL ICE MACHINES FROM 60KG./24H. TODAS MÁQUINAS HIELO DESDE 60KG./24H.

ACCESORIES

FEATURES | CARACTERÍSTICAS

	REF:	DIMENSIONS DIMENSIONES mm.	FOR MACHINES PARA LOS MODELOS
SINGLE ICE CHUTE ICE QUEEN TUBO CAÍDA DE HIELO SIMPLE ICE QUEEN	6682	 70 x 70 x 1200	IQ 150/200/400/550
DOUBLE ICE CHUTE ICE QUEEN TUBO CAÍDA DE HIELO DOBLE ICE QUEEN	6683	 2UND. 70 x 70 x 1200	IQ 1100
REMOTE SWITCH SCALA INTERRUPTOR REMOTO SCALA	6761		SCALA
REMOTE SWITCH & WEEKLY PROGRAMMER INTERRUPTOR REMOTO CON PROGRAMADOR SEMANAL	8330		SCALA
REMOTE SWITCH & PHOTOCELL SENSOR DE PARO EXTERNO FOTOCÉLULA CON INTERRUPTOR A DISTANCIA	5275		IQ, SCALA
ICE CHUTE SCALA 400, 600 TUBO CAÍDA DE HIELO INOX SCALA 400, 600	6908	 300 x 300 x 1200	SCALA 400, 600
ICE CHUTE SCALA 1, 1.5, 2, 3T TUBO CAÍDA DE HIELO INOX SCALA 1, 1.5, 2, 3T	6716	 400 x 400 x 1200	SCALA 1, 1.5, 2, 3T
Y SHAPED EXTENSION SCALA EXTENSIÓN Y SCALA	6721		SCALA 1, 3T
20 L. BOTTLE FOR SCALA SALT DOSER BIDÓN 20 L. PARA DOSIFICADOR SCALA	48325		SCALA
SALT DOSER SCALA BOMBA DOSIFICADORA DE SAL SCALA	49094		SCALA
SMALL SCOOP PALA PEQUEÑA	844		
MEDIUM SCOOP PALA MEDIANA	176		
LARGE SCOOP PALA GRANDE	910		
HEIGHT ADJUSTABLE LEG PATA ALTURA REGULABLE	1478		
WHEELS KIT RUEDAS	6430		
STACKING KIT MDP 150 KIT APILADO MDP150	8034		
STACKING KIT MR400 KIT APILADO MR400	8035		
STACKING KIT MR400 KIT APILADO SPIKA MS	6586		

ACCESORIOS

FEATURES | CARACTERÍSTICAS

	REF:	DIMENSIONS DIMENSIONES mm.	FOR MACHINES PARA LOS MODELOS
LÁMPARA UV UV LAMP	31266		
PUMP WITH REMOTE STOP BOMBA DESCARGA EXTERNA	6470		
KIT 6 CESTAS CARROS 6 BASKET KIT FOR CARTS	30501		
ICE BAGGER EMBOLSADORA	32178		
KIT 50 BOLSAS PARA EMBOLSADORA 50 BAGS KIT FOR ICE BAGGER	32570		
4 SMALL WHEELS KIT KIT 4 RUEDAS PEQUEÑAS	31703		
EXTERNAL FAULT SIGNALING KIT KIT SEÑALIZACIÓN AVERÍA EXTERNA	32507		SCALA

CHILLERS

ENFRIADORA DE AGUA

For pre-cooling the mains water and reducing its temperature to improve the performance of the ice maker.
Sirven para preenfriar el agua de red y reducir su temperatura para mejorar el rendimiento de la máquina de hielo.



CARACTERÍSTICAS

WATER T° INPUT/ OUT PUT T° ENTRADA/ SALIDA EVAPORADOR	COOLING POWER POTENCIA FRIGORIFRICA	L/HOUR L./HORA	FOR MACHINES MODELS PARA LOS MODELOS DE MÁQUINAS DE HIELO	COMPRESSOR COMPRESOR	V/Hz VOLTAJE/ FRECUENCIA	DIMENSIONS (mm.) WIDTH x DEEP x HIGH DIMENSIONES (mm.) ANCHO x PROF. x ALTO	NET WEIGHT WITHOUT HIDRONIC MODUL PESO SIN MÓDULO HIDRÓNICO
WATER INPUT T° T° ENTRADA	WATER OUTPUT T° T° SALIDA AGUA					X Y Z	Kg.

CHILLERS / ENFRIADORA AGUA 6

REF: 19023

T° AMBIENTE	35°C	30°C	18°C	3,8	180	HASTA 6 UDS. DE LA MR400, 8 UDS. ICE QUEEN 550, 4 UDS. ICE QUEEN 1100, SCALA HASTA 3T.	SCROLL	400 V / 50 Hz	900	1100	1460	110
T° AMBIENTE	43°C	35°C	23°C	3,8	100	HASTA 3 UDS. DE MR400, 4 UDS. ICE QUEEN 550, 2 UDS. ICE QUEEN 1100, SCALA HASTA 2T.						

CHILLERS / ENFRIADORA AGUA 10

REF: 19024

T° AMBIENTE	35°C	30°C	18°C	8,2	390	SCALA 3T, 5T.	SCROLL	400 V / 50 Hz	900	1100	1460	190
T° AMBIENTE	43°C	35°C	23°C	8,2	225	SCALA 3T, 5T.						

CHILLERS / ENFRIADORA AGUA 15

REF: 19025

T° AMBIENTE	35°C	30°C	18°C	15,1	720	SCALA 10T.	SCROLL	400 V / 50 Hz	1100	1100	1460	223
T° AMBIENTE	43°C	35°C	23°C	15,1	423	SCALA 10T.						

ITV RECOMMENDS

RECEPTION OF THE MACHINE

Upon reception of the machine, you should check that it has not suffered damage in transport. The machines leave ITV having been checked and balanced, but in transport they may suffer some type of damage so, they should be checked before installation. The machine itself should be checked, not just the outside of the packaging, because vertical drops from the truck or blows from blunt objects could have occurred that may have damaged the machine although the packaging is in good condition.

UNPACKING

Cut the clips, and remove the cardboard box and plastic bag. In some models you must remove two M6 Allen bolts that secure the machine to the pallet.

In the inside of the machine you will find:

- Legs. Screw to the machine bedplate.
- Water intake and filters.
- Drain hose and clamp.
- Plastic scoop ice dispenser.
- User manual. Save for future reference.
- Warranty Card. Fill out and send by mail to ITV for warranty control and date of installation of the machine. You can also do this online at www.itv.es, "**Service, Warranty Registration**".
- Behind the curtains you will find two corks or tapes that secure the parts in place to avoid movement in transport. Take them off. (Only in solid cube machines).

INSTALLATION OF THE MACHINE ON THE PREMISES

The machine must be installed in a place with sufficient ventilation for proper operation.

You should avoid, as far as possible, any water cooler of heat around the machine such as refrigeration equipment, ovens, etc. as you might decrease the efficiency of the condenser or heating the water inlet hose, which would decrease the production of ice, and compromise the durability of the machine components.

For the installation of the machine the following is necessary:

- Electrical connection.
- Water intake.
- Drainage.

Before carrying out the installation of a machine you must have, for convenience, the necessary connections depending on the number of machines to be installed. Each one of

the machines should have an individual circuit breaker for greater safety in operation and in order to avoid damage if there are problems with the mains electricity.

Refer to the manual for proper sizing of the circuit breaker. Some models of modular machines may be three phase 380V+III+N.

IMPORTANT: all electrical connections must be earthed. Check that the voltage coincides with the plate.

With the machine a flexible water connection is sent (1.5m). At one of the ends, there is an elbow; this is the part of the connection that is connected to the outlet on the machine. If it is not connected in this way, you run the risk of the hose getting bent and the water not passing through at the correct pressure, of between (0.7 and 6 kg/cm. (10/85 psi). At each end of the connection you should install one of the filters that are sent with the kit.

If necessary, you could install a pressure reducer to avoid potential problems.

The drain where we are going to send the excess water should never be higher than the machine's outward drain. It should be at least 150mm below the drainage of the machine and with a diameter of 30mm. If the drainage pipe that the machine has is too long, it can be adjusted by cutting it to the necessary length. See specific model instructions.

FIRST START-UP

Once the machine is installed, in order to start it up you must carry out the following steps:

1. Is the machine correctly levelled?
2. Are the drains properly connected?
3. Is the water pressure correct? If not, install a regulator.
4. Turn on the water.
5. Plug in the machine.

Before consuming the ice produced by the machine it is necessary to carry out two ice cycles in order to remove impurities that have been left in the water circuit.

We hope that you enjoy the ice produced by your new ITV ice machine.

MAINTENANCE

For proper operation of the machines it is recommended that you carry out the maintenance tasks, which are listed in the user manual that accompanies each ITV machine, as well as in the diverse ITV Technical Manuals.

SEE SAT ITV

Ex works Valencia (Spain) prices in force.

RETURNS

- Returns of material are not accepted except with specific authorization from ITV.
- If returned merchandise is accepted, it must be returned to ITV warehouse under freight paid.

DELIVERY ISSUES

If there is any problem upon receiving the merchandise, we hereby inform you of the steps to follow for reception:

- The merchandise travels at the expense and risk of the receiver, even when it travels prepaid freight. Covered by the agency insurance.
- The merchandise must be checked at the moment of receipt, in case there are any faults.
- If it is not possible to check the merchandise at the time of delivery, the delivery note will be signed with the indication.
- IN AGREEMENT PENDING SUBSEQUENT EXAMINATION, checking the date of the delivery note.
- If the foregoing note is written, the observed damage must necessarily be communicated to the agency, via fax so that a written record exists. FOR THIS COMMUNICATION THERE IS A MAXIMUM LEGAL TIME PERIOD OF 24 HOURS, taking into account the date of the delivery note.

WARRANTY

ITV offers a twenty-four months guarantee for parts valid from date of delivery from factory.

In order for the warranty to apply, the machine must be operated under the conditions specified by the manufacturer, including the necessary filters in case of extremely hard or soft water.

Check **www.itv.es**

To permit the incorporation of improvements derived from

our constant research, these characteristics may be modified without prior notice.

Once completed their useful life, all ITV machines must be treated as WEEE.

Please contact **+34 961 66 75 75** or **info@itv.es**

ITV RECOMIENDA

RECEPCIÓN DE LA MÁQUINA

A la recepción de la máquina debemos comprobar que no haya sufrido daños en el transporte. Las máquinas salen de ITV revisadas y equilibradas, pero en el transporte pueden sufrir algún tipo de desperfecto, por lo que debemos revisarlas antes de su instalación. Se debe comprobar la máquina, no sólo el exterior del embalaje, pues pueden haberse producido caídas verticales desde el camión o golpes con objetos no punzantes que pueden haber dañado la máquina aunque el embalaje esté en buen estado.

DESEMBALAJE

Cortar los flejes, y retirar la caja de cartón y bolsa de plástico. En algunos modelos hay que retirar además dos tornillos Allen M6 que fijan la máquina al palet.

En el interior de la máquina encontraremos:

- Patas. Deben atornillarse a la bancada de la máquina.
- Toma de agua y junta-filtro.
- Manguera desagüe y abrazadera.
- Pala de plástico dispensadora de hielo.
- Manual del Usuario. Guardar para posteriores consultas.
- Tarjeta de Garantía. Rellenar y enviar por correo a ITV para control de garantía y fecha de instalación de la máquina. También puede hacerlo on-line en www.itv.es, Servicio, "Registro de Garantía".
- En máquinas de cubito macizo detrás de las cortinas de plástico internas encontraremos dos corchos o cintas que fijan las piezas para evitar movimientos en el transporte. Retirarlos.
- (Sólo en máquinas de cubito macizo).

INSTALACIÓN DE LA MÁQUINA EN EL LOCAL

La máquina debe estar instalada en un lugar con una ventilación suficiente para el correcto funcionamiento. Debemos evitar en la medida de lo posible, cualquier foco de calor alrededor de la máquina; como equipos de refrigeración, hornos...etc., ya que por este motivo podríamos disminuir la eficiencia del condensador o calentar la manguera de entrada de agua, lo que haría disminuir la producción de hielo, estresar la máquina y comprometer la durabilidad de los componentes de la misma.

Para la instalación de la máquina hay que prever:

- Conexión eléctrica.
- Toma de agua.
- Desagüe. Antes de realizar la instalación de una máquina debemos prever para nuestra comodidad las conexiones necesarias dependiendo del número de máquinas a instalar.

Cada una de las máquinas debe tener un interruptor magnetotérmico individual para mayor seguridad en el funcionamiento y para evitar averías en caso de tener problemas con la red eléctrica. Consultar el manual para dimensionar adecuadamente el magnetotérmico. Algunos modelos de máquinas modulares pueden ser trifásicos 380V+III+N.

IMPORTANTE: Todas las conexiones eléctricas deben llevar su toma de tierra correspondiente. Comprobar que la tensión coincide con la indicada en la placa de características de la máquina.

Con la máquina se envía una acometida flexible de agua (1,5m). En uno de los extremos lleva un codo, ésta es la parte de la acometida que va conectada a la toma de la máquina. En caso de no conectarlo así, corremos el riesgo de que la manguera quede doblada y no pase el agua a la presión correcta, comprendida entre (0,7 y 6 kg./cm.) (10/85 psi). En cada uno de los extremos de la acometida debemos colocar la junta-filtro que se envía también. En caso de presiones en la red de agua mayores a 6Kg./cm., podríamos instalar un reductor de presión para evitar posibles problemas.

El desagüe al cual vamos a enviar el agua sobrante, nunca debe estar más alto que el desagüe de salida de la máquina. Como mínimo debe estar 150mm. por debajo del desagüe de la máquina y que tenga un diámetro de 30mm. Si la tubería de desagüe que lleva la máquina es demasiado larga podemos ajustarla cortándola a la medida necesaria. Consultar instrucciones específicas del modelo.

PRIMERA PUESTA EN MARCHA

Una vez instalada la máquina, para realizar la puesta en marcha hay que realizar los siguientes pasos:

1. ¿La máquina está bien nivelada?
2. ¿Los desagües están bien conectados?
3. ¿La presión de agua es la correcta? En caso contrario colocar un regulador.
4. Abrir el agua.
5. Enchufar la máquina.

Antes de consumir el hielo producido por la máquina debemos realizar 2 ciclos de hielo para eliminar impurezas que hayan podido quedar en el circuito de agua. Esperamos que disfrute el hielo producido por su nueva máquina ITV.

MANTENIMIENTO

Para el correcto funcionamiento de las máquinas se recomienda realizar las tareas de mantenimiento indicadas para cada una que figuran en el manual del usuario que acompaña cada máquina de ITV, así como en los diversos manuales Técnicos de ITV. En caso de duda, consultar con el Servicio Técnico de ITV.

La limpieza periódica de las máquinas de hielo es necesaria para asegurar un correcto funcionamiento de las mismas. ITV recomienda realizar la limpieza una vez al año, siguiendo las recomendaciones descritas en el manual de usuario de cada modelo de máquina y aumentar la frecuencia en caso de aguas con mayor dureza.

CONDICIONES DE VENTA

- Precios Ex works Valencia (España) en vigor.
- Repuestos: Todos los pedidos de repuestos serán facturados en condiciones COD (Cash On Delivery)

DEVOLUCIONES

No se acepta la devolución de material sin autorización expresa de ITV por escrito.

En caso de aceptar la devolución, la mercancía se devolverá al almacén de ITV a portes pagados.

INCIDENCIAS EN EL TRANSPORTE

La mercancía se ha de comprobar en el momento de la recepción, por si existe algún desperfecto.

Si al recibir su mercancía observa que se ha producido alguna incidencia en el transporte, golpeo del embalaje, mojado, etc...la manera de actuar es la siguiente:

- El cliente receptor de la mercancía debe reflejar esta incidencia en el albarán de la agencia de transporte, antes de firmar el mismo. Inmediatamente después, debe comunicar este hecho a ITV por escrito, que a su vez dará parte a la agencia de transportes. PARA ESTA COMUNICACIÓN HAY UN PLAZO LEGAL MÁXIMO de 24 HORAS, que es el estipulado en la cobertura del seguro de transporte.
- Transcurridas estas 24h. sin haber notificado la incidencia correspondiente, ni la compañía de seguros ni la agencia de transporte atienden reclamación alguna, por lo que ITV declina cualquier responsabilidad sobre incidencias recibidas fuera de plazo.
- La mercancía viaja por cuenta y riesgo del receptor, aun cuando vaya a portes pagados.

- En caso de no poder revisar la mercancía en el momento de la entrega, se firmará un albarán con la indicación: CONFORME SALVO EXAMEN POSTERIOR, comprobando que la fecha del albarán es la correcta.
- ITV comunica a sus clientes en todo momento los plazos de tránsito aportados por la agencia de transporte, pero no se hace responsable de posibles retrasos de la agencia en el cumplimiento de los mismos.

GARANTÍA

Las máquinas de ITV tienen una garantía en piezas de 24 meses desde el suministro de las mismas.

Para la aplicación de la garantía se requiere que la máquina funcione dentro de las condiciones que indica el fabricante, incluyendo los filtros necesarios en caso de aguas duras o blandas excesivamente.

Para más detalles, consulte www.itv.es

Para permitir incorporar las mejoras derivadas de nuestra constante investigación, estas características podrán ser modificadas sin previo aviso.

Una vez completada su vida útil, todas las máquinas ITV deben tratarse como RAEE.

Por favor, contactar con **+34 961 66 75 75** o info@itv.es

NOTES

C/49092_17/A/20_V3

THE COMPANY RESERVES THE RIGHT TO MODIFY MODELS, FEATURES AND PRICES WITHOUT PRIOR NOTIFICATION.
LA EMPRESA SE RESERVA EL DERECHO DE MODIFICAR MODELOS, CARACTERÍSTICAS Y PRECIOS SIN NOTIFICACIÓN PREVIA.



ITV ICE MAKERS, S.L.

POL. IND. SECTOR 13, AVDA. DELS HOSTALERS, 2
46394 RIBAIREROJA DE TURIA, VALENCIA, SPAIN
PHONE: +34 96 166 75 75 | FAX: +34 96 166 81 00
comercial@itv.es | www.itv.es