



 **nuova**  
**SIMONELLI**<sup>®</sup>  
espresso coffee machines

## La migliore Aurelia di sempre

**IT** Indubbiamente una Aurelia, eppure... Ma ora con qualcosa in più. Aurelia II, la macchina preferita dai migliori baristi, oggi si arricchisce della nuova tecnologia Easy Cream, per soddisfare ancora di più le esigenze di un vasto settore che mira all'eccellenza.

Una macchina forte e di carattere che implementa la sua già elevata tecnologica.



WBC Rimini 2014, Hidenori Izaki

WBC Melbourne 2013, Pete Licata



WBC Vienna 2012, Raul Rodas



### Aurelia the best ever

**EN** Undoubtedly an Aurelia, and yet... Now with a little more. Aurelia II, the favorite coffee machine of the best baristas is enriched with the new **Easy Cream** technology to meet a big sector needs, always aiming for excellence.

A strong and character machine increasing its high technology.

### La meilleure Aurelia de tous les temps

**FR** Une Aurelia sans aucun doute... Mais avec quelque chose en plus. Aurelia II, la machine préférée des meilleurs barmen, s'enrichit aujourd'hui de la nouvelle technologie **Easy Cream** pour mieux satisfaire les nouveaux besoins d'un vaste secteur visant l'excellence.

Une machine à fort caractère, déjà de haut niveau d'un point de vue technologique.

### Die beste Aurelia aller zeiten

**DE** Zweifelsohne eine Aurelia, und dennoch... Nun noch etwas mehr. Aurelia II, die Lieblingsmaschine der besten Barmänner, ist um eine technische Innovation, **Easy Cream**, reicher. Stets die neuen Anforderungen einer großen Branche, die auf Exzellenz achtet, im Blick.

Eine solide, zuverlässige und hochtechnologische Maschine.

### La mejor Aurelia de siempre

**ES** Sin duda una Aurelia, sin embargo... Ahora con algo más. Aurelia II, la máquina preferida por los mejores baristas, hoy se enriquece de la nueva tecnología **Easy Cream**, para satisfacer aún más las nuevas exigencias de un amplio sector que apuesta por la excelencia.

Una máquina fuerte y de carácter que implementa su ya elevada tecnológica.



nuova  
**SIMONELLI**

## EASY CREAM

### Cappuccini perfetti, sempre.

**IT** Alla base della preparazione di un perfetto cappuccino ci sono l'esperienza e la tecnica del barista. A coloro che ancora non hanno raggiunto questi livelli arriva in aiuto la tecnologia **Easy Cream**.

La flessibilità dell'innovativo sistema latte offre ampie possibilità in relazione alle preferenze della clientela: più o meno cremoso e con una temperatura stabilita. E per i più esigenti è previsto anche il secondo pulsante di programmazione.\*

\* Possibilità consentita solo sulla lancia destra delle versioni Digit e T3.



## EASY CREAM

**Perfect cappuccino, always.**

**EN** The foundation of preparing a perfect cappuccino is always the barista's technique and expertise. **Easy Cream** technology can help those who have not yet reached these high levels. The milk system flexibility offers great opportunities in relation to customer preferences: more or less creamy and with a defined temperature. And for the most demanding Aurelia II is also provided to the second programming button.\*

\* Only on Digit and T3 version.

## EASY CREAM

**Des cappuccinos toujours parfaits.**

**FR** La préparation d'un cappuccino parfait passe par l'expérience et la technique du barman. Pour les moins experts, il y a technologie **Easy Cream**. La flexibilité du système à lait innovant offre de vastes possibilités permettant de répondre aux demandes spécifiques de chaque client: plus ou moins crémeux avec une température définie. Et pour les plus exigeants, une seconde touche de programmation a également été prévue.\*

\* Possibilité permise uniquement sur la lance droite des versions Digit et T3.

## EASY CREAM

**Immer ein perfekter Cappuccino.**

**DE** Grundvoraussetzung für einen perfekten Cappuccino ist das Können, die Technik des Barmanns. Mit der **Easy Cream** Technologie gelingt der Cappuccino auch mit weniger Erfahrung. Durch das flexible, innovative Milchsystem wird mach einfach allen Kundenwünschen gerecht: mehr oder weniger cremig und mit einer bestimmten Temperatur. Und für die Anspruchsvollsten gibt es auch eine Programmierungstaste.\*

\* Diese Möglichkeit gibt es nur am rechten Dampfrohr der Ausführungen Digit und T3.

## EASY CREAM

**Capuchinos perfectos, siempre.**

**ES** El fundamenti de un perfecto capuchino es la experiencia y la técnica del barista. A aquellos que todavía no han alcanzado estos niveles llega para ayudarles la tecnología **Easy Cream**. La flexibilidad del innovador sistema leche ofrece amplias posibilidades con relación a las preferencias de la clientela: más o menos cremosa y con una temperatura establecida. Y para los más exigentes está previsto el segundo botón de programación.\*

\* Posibilidad que solo se permite en la boquilla derecha de las versiones Digit y T3.

### How it works

**IT** L'Easy Cream riproduce esattamente i gesti del bravo barista: in una prima fase bilancia l'iniezione di vapore caldo ed aria, poi quando il latte ha raggiunto una temperatura intermedia, che è programmabile, arresta il flusso di aria, lasciando solo l'azione del vapore fino al raggiungimento della temperatura ottimale.

**EN** **Easy Cream** exactly reproduces the actions of good barista, firstly balancing the injection of steam and air. When the milk reaches an intermediate temperature, which can be programmed, the airflow stops. From then on, steam to heat the milk until it reaches the optimum temperature.

**FR** Le système **Easy Cream** reproduit exactement les gestes d'un barman expérimenté: dans un premier temps, le système équilibre l'injection de vapeur d'eau chaude et d'air puis, lorsque le lait a atteint une température intermédiaire, laquelle est programmable, il bloque le flux d'air, laissant uniquement agir la vapeur jusqu'à la température optimale.

**DE** **Easy Cream** ahmt die Handgriffe eines guten Barmanns nach: zunächst wird der Dampf-Luft-Strahl eingestellt, und sobald die Milch auf eine mittlere, programmierbare Temperatur erwärmt ist, wird die Luftströmung gestoppt. Der reine Dampfstrahl bringt die Milch weiter auf die ideale Temperatur.

**ES** **Easy Cream** reproduce exactamente los gestos del buen barista: en una primera fase equilibra la inyección de vapor caliente y aire, a continuación, cuando la leche ha alcanzado una temperatura intermedia (programable), para el flujo de aire, dejando solo la acción del vapor hasta que se alcance la temperatura óptima.

### How it is made

**IT** Il nuovo terminale della lancia, con fori tangenziali a diversa inclinazione, imprime un moto rotatorio al liquido per amalgamarne la consistenza; il risultato è davvero sorprendente.

**EN** The new end of the nozzle, with tangential holes at different angles, makes the liquid rotate to get the perfect consistency; the result is truly amazing.

**FR** Le nouvel embout de la buse, équipé de trous tangentiels à inclinaisons différentes, applique un mouvement rotatif au liquide afin d'en amalgamer la consistance. Le résultat est vraiment étonnant.

**DE** Das neue Endstück des Dampfrohrs mit tangentialen, unterschiedlich geneigten Öffnungen überträgt eine Drehbewegung die Flüssigkeit, um eine sämige Konsistenz zu erreichen; das Ergebnis ist wirklich erstaunlich.

**ES** El nuevo terminal de la boquilla, con los orificios tangenciales de diferente inclinación, imprime un movimiento rotatorio al líquido para amalgamar la consistencia, el resultado es verdaderamente sorprendente.

### Main result

**IT** Ancora più sorprendente è la costanza di risultato: ogni montatura ha la stessa qualità e identica temperatura, a prescindere dalla dimensione della caraffa o dal volume di latte.

**EN** Even more surprising is the consistency. Each serving has the same quality and the same temperature, regardless of the size or volume of the milk jug.

**FR** Le résultat est encore plus surprenant: chaque crème de lait obtenue est de qualité identique et à la même température, quelle que soit la taille du pot à lait ou du volume de lait.

**DE** Und noch überraschender ist die Konstanz des Ergebnisses: unabhängig von Milchkanne und Milchkanne sind Qualität und Temperatur bei jedem Aufschäumen identisch.

**ES** Aún más sorprendente es la constancia de resultado: cada vez que se monta, la leche tiene la misma calidad e idéntica temperatura, independientemente del tamaño de la jarra o del volumen de leche.



## Prestazioni e consistenza



Performance  
and consistency

Performances  
et consistance

Leistung  
und Konstanz

Prestación  
y consistencia



**SIS**  
Soft Infusion  
System

**IT** Aurelia II ripropone il già collaudato sistema SIS che è sinonimo di estrazioni cremose e di qualità superiore.



**EN** Aurelia II presents again the tested SIS system that is synonymous with superior quality and creamy extractions.

**FR** Aurelia II repropose le système SIS déjà largement testé, synonyme d'extractions crémeuses et de qualité supérieure.

**DE** Aurelia II bietet auch das bewährte System SIS, welches für cremigen Espresso von höchster Qualität steht.

**ES** Aurelia II vuelve a proponer el ya probado sistema SIS que es sinónimo de extracciones cremosas y de calidad superior.



**PID**  
Proportional  
Integral  
Derivative

**IT** L'innovativo pressostato digitale è uno strumento molto accurato nel determinare con precisione la temperatura dell'acqua in caldaia. Il barista può controllarla e programmarla direttamente dal display.

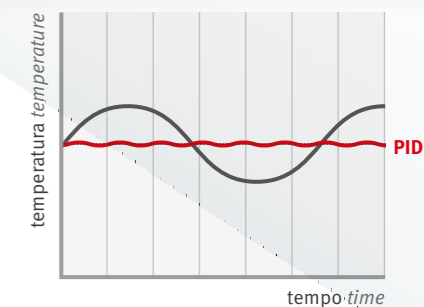

**EN** This innovative digital pressure switch is a very accurate tool determining the precise temperature of water in the boiler. The barista can control and program it directly from the display.

**FR** Le nouveau pressostat digital est un instrument très précis pour déterminer la température de l'eau dans la chaudière. Le barman peut la contrôler et la programmer directement depuis l'afficheur.

**DE** Dieser innovative digitale Druckschalter ist ein sehr genaues Instrument zur exakten Feststellung der Wassertemperatur im Boiler. Der Barista kann sie direkt am Display kontrollieren und programmieren.

**ES** El innovador pressostato digital es un instrumento muy preciso para determinar con exactitud la temperatura del agua en la caldera. El barista puede controlarla y programarla directamente desde la pantalla.

## Versatilità e funzionalità

Versatility  
and functionality

Versabilité  
et fonctionnalité

Vielseitigkeit  
und Funktionalität

Versatilidad  
y funcionalidad



### **Raised groups**

**IT** La macchina può essere richiesta con i gruppi ad altezza regolare (80 mm) o ad altezza maggiorata (125 mm) se si vuole operare anche con bicchieri alti.

**EN** The machine can be ordered with regular height groups (80 mm) or raised height groups (125 mm) if you also want to work with tall glasses.

**FR** La machine peut être commandée avec les groupes à hauteur normale (80 mm) ou à une hauteur supérieure (125 mm) si on désire travailler aussi avec des verres hauts.

**DE** Die Maschine kann auf Anfrage mit Brühgruppen auf normaler Höhe (80 mm) oder mit nach oben verlagerten Brühgruppen (125 mm) geliefert werden, wenn z.B. hohe Gläser verwendet werden sollen.

**ES** La máquina se puede solicitar con los grupos a una altura regular (80 mm) o a una altura aumentada (125 mm) si se desea trabajar también con los vasos altos.



### **Automatic cleaning**

**IT** Aurelia II permette di fare la pulizia automatica indipendente su ogni singolo gruppo. Il lavaggio diventa così sinergico con gli orari di esercizio e non serve più attendere la chiusura.

**EN** Aurelia II allows independent automatic cleaning of each individual group. Washing and operating hours can be carried out simultaneously. No need to wait for closing time.

**FR** Aurelia II permet d'effectuer un nettoyage automatique indépendant de chaque groupe. Le lavage devient ainsi synergique avec les horaires de service et il ne faut plus attendre la fermeture de l'établissement.

**DE** Aurelia II gestattet die automatische und unabhängige Reinigung der einzelnen Brühgruppen. Das Ausspülen erfolgt also in Synergie mit den Betriebszeiten und es muss nicht mehr gewartet werden, bis das Lokal geschlossen wird.

**ES** Aurelia II permite hacer la limpieza automática independiente en cada uno de los grupos. El lavado entra en sinergia con los horarios de funcionamiento y ya no hace falta esperar al cierre.

## Confort e benessere

**IT** Aurelia II conferma l'attenzione della Nuova Simonelli per la tutela ed il benessere del barista.

Dal punto di vista ergonomico, oltre a riproporre tutte le soluzioni che hanno reso la sua antenata la prima macchina al mondo ergonomicamente certificata (Leve Push&Pull, Portafiltri inclinati, Ampia visuale piano lavoro...), Aurelia II presenta nuovi interessanti accorgimenti.



Leather filter holder

## Comfort and well-being

**EN** Aurelia II confirms Nuova Simonelli's interest in the protection and well-being of the barista.

From the ergonomic point of view, in addition to reproducing all the solutions that made its predecessor the world's first ergonomically certified coffee machine (Push&Pull levers, slanting filter holders, high visibility work surface...) Aurelia II presents interesting new devices.

## Confort et bien-être

**FR** Aurelia II confirme l'attention de Nuova Simonelli pour la sécurité et le bien-être du barman.

Du point de vue ergonomique, outre toutes les solutions qui ont permis à son ancêtre d'être la première machine au monde ergonomiquement certifiée (leviers Push&Pull, Porte-filtres inclinés, Vaste vue sur le plan de travail...), Aurelia II présente de nouveaux détails importants.

## Komfort und Wohlbefinden

**DE** Aurelia II bestätigt das Interesse von Nuova Simonelli für die Sicherheit und das Wohlbefinden des Barista.

Unter ergonomischen Gesichtspunkten bietet Aurelia II außer den Lösungen, die aus dem Vorgänger die erste Maschine der Welt mit Ergonomie-Zertifikat (Push&Pull-Hebel, schräge Siebhalter, gute Übersicht über die Arbeitsfläche...) gemacht haben, neue und interessante Eigenschaften.

## Confort y bienestar

**ES** Aurelia II confirma la atención de la Nuova Simonelli por la tutela y el bienestar del barista.

Desde el punto de vista ergonómico, además de volver a proponer todas las soluciones que han hecho su antecesor la primera máquina en el mundo ergonómicamente certificada (Palancas Push&Pull, portafiltros inclinados, Amplia visual plano de trabajo...) Aurelia II presenta nuevos interesantes detalles.

1 Push&pull 2 Wide view 3 Conical handel 4 Inclined handle 5 Reverse mirror

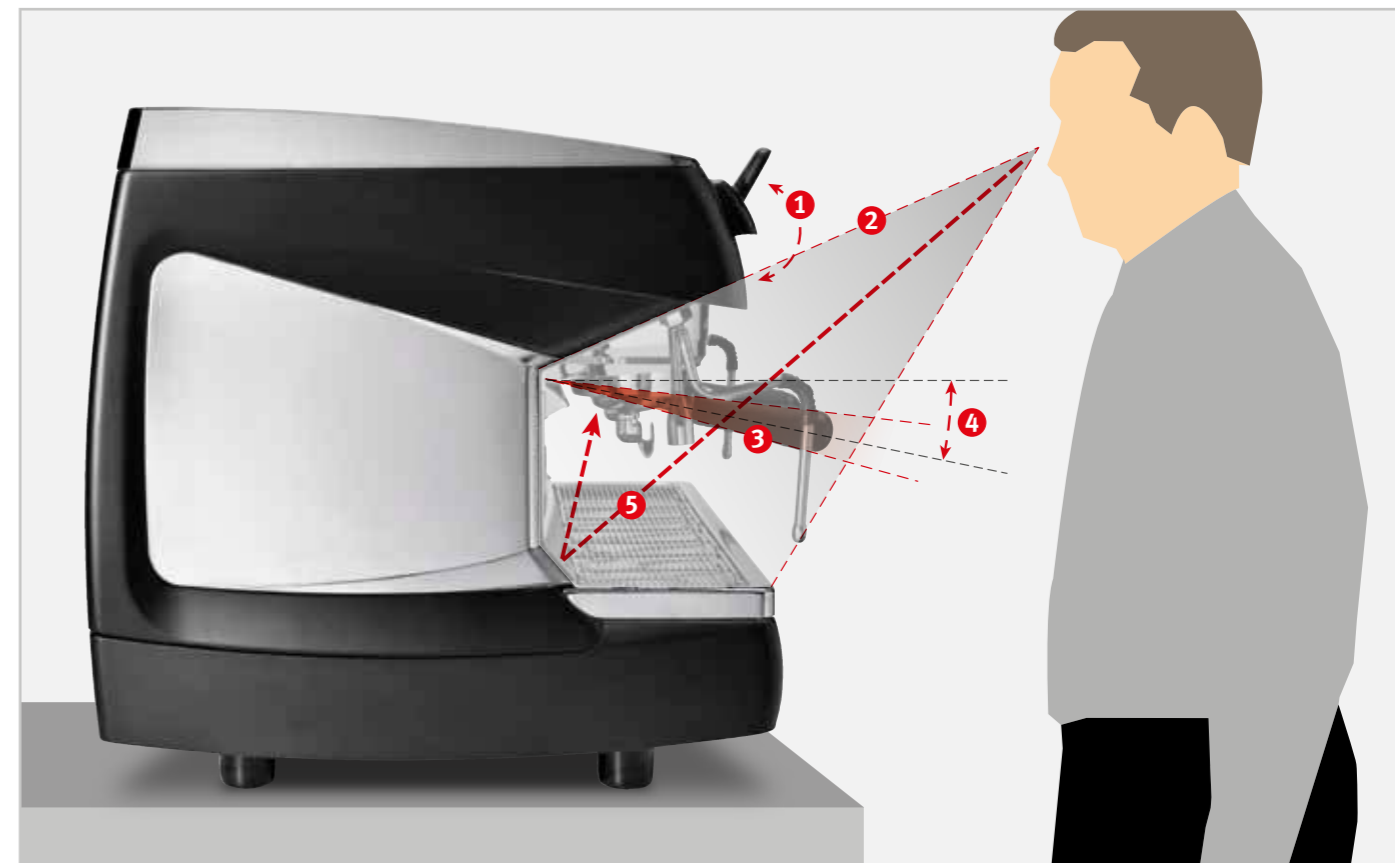



**Reverse mirror**

**IT** Consente al barista di osservare l'uscita del caffè dal portafiltro senza doversi chinare. Una piccola accortezza che sarà molto apprezzata dai baristi professionisti.

**EN** It allows the barista to watch the coffee filter output without bending down. A little foresight that will be appreciated by professional baristas.

**FR** Permet au barman d'observer l'extraction du café qui sort du porte-filtre sans devoir se pencher. Un petit détail qui sera très apprécié par les barmans professionnels.

**DE** Gestattet es dem Barista, das Auslaufen des Kaffees aus dem Sieb zu beobachten, ohne sich bücken zu müssen. Eine kleine Aufmerksamkeit, die ein Profi-Barista sicher zu schätzen weiß.

**ES** Permite al barista observar la salida del café desde el portafiltro sin tenerse que inclinar. Un pequeño detalle que será muy apreciado por los baristas profesionales.



**Milk light**

**IT** Porta luce all'interno del bricco latte, ovvero in uno degli angoli più bui per il barista, permettendogli di visualizzare ottimamente la fase di montaggio.

**EN** Lighting the inside of the milk jug, till now one of the darkest corners for the barista, allowing optimal sight of the foaming phase.

**FR** Point d'éclairage à l'intérieur du broc à lait, dans l'un des angles les plus obscurs pour le barman, lui permettant ainsi de voir parfaitement la phase de montage du lait.

**DE** Bringt Licht ins Innere des Milchkännchen, d.h. in einen der für den Barista dunkelsten Winkel, so dass er das Aufschäumen der Milch bestens sehen kann.

**ES** Hace luz dentro de la jarrita de la leche, o sea, en una de las esquinas más oscuras para el barista, permitiéndole visualizar de manera óptima la fase de montaje.



**LED light**

**IT** Nuovo anche il sistema di illuminazione del piano lavoro che garantisce uniforme intensità di luce su tutta la superficie.

**EN** The work surface lighting system is also new, guaranteeing uniform light intensity over the entire surface.

**FR** Nouveauté aussi pour le système d'éclairage du plan de travail qui garantit une intensité de lumière uniforme sur toute la surface.

**DE** Eine weitere Neuerung ist das Beleuchtungssystem der Arbeitsfläche, welches eine gleichmäßige Ausleuchtung der gesamten Fläche gewährleistet.

**ES** También es nuevo el sistema de iluminación del plano de trabajo que garantiza uniforme intensidad de luz en toda la superficie.



**Cool touch**

**IT** Le lance vapore hanno il sistema brevettato *cool touch*, che, oltre a garantire maggiore sicurezza contro fastidiose ustioni, assicura una più facile pulizia; stop alle incrostazioni di latte.

**EN** The steam nozzles have the patented *cool touch* system, which in addition to greater security against annoying scalding, ensures easy cleaning; no more milk encrustation.

**FR** Les buses vapeur ont un système breveté *cool touch*, qui, outre à garantir une majeure sécurité d'emploi contre le risque de brûlures, assure un nettoyage simplifié; finies les incrustations de lait.

**DE** Die Dampfrohre sind mit dem patentierten System *cool touch* ausgestattet, das nicht nur unangenehmen Verbrennungen vorbeugt, sondern auch die Reinigung erleichtert. Schluss mit festgebackener Milch.

**ES** Las boquillas de vapor tienen el sistema patentado *cool touch*, que, además de garantizar mayor seguridad contra fastidiosas quemaduras, asegura una limpieza más fácil; stop a las incrustaciones de leche.

## Razionalità e semplicità

Rationality  
and simplicity

Rationalité  
et simplicité

Klarheit und  
Übersichtlichkeit

Racionalidad  
y simplicidad

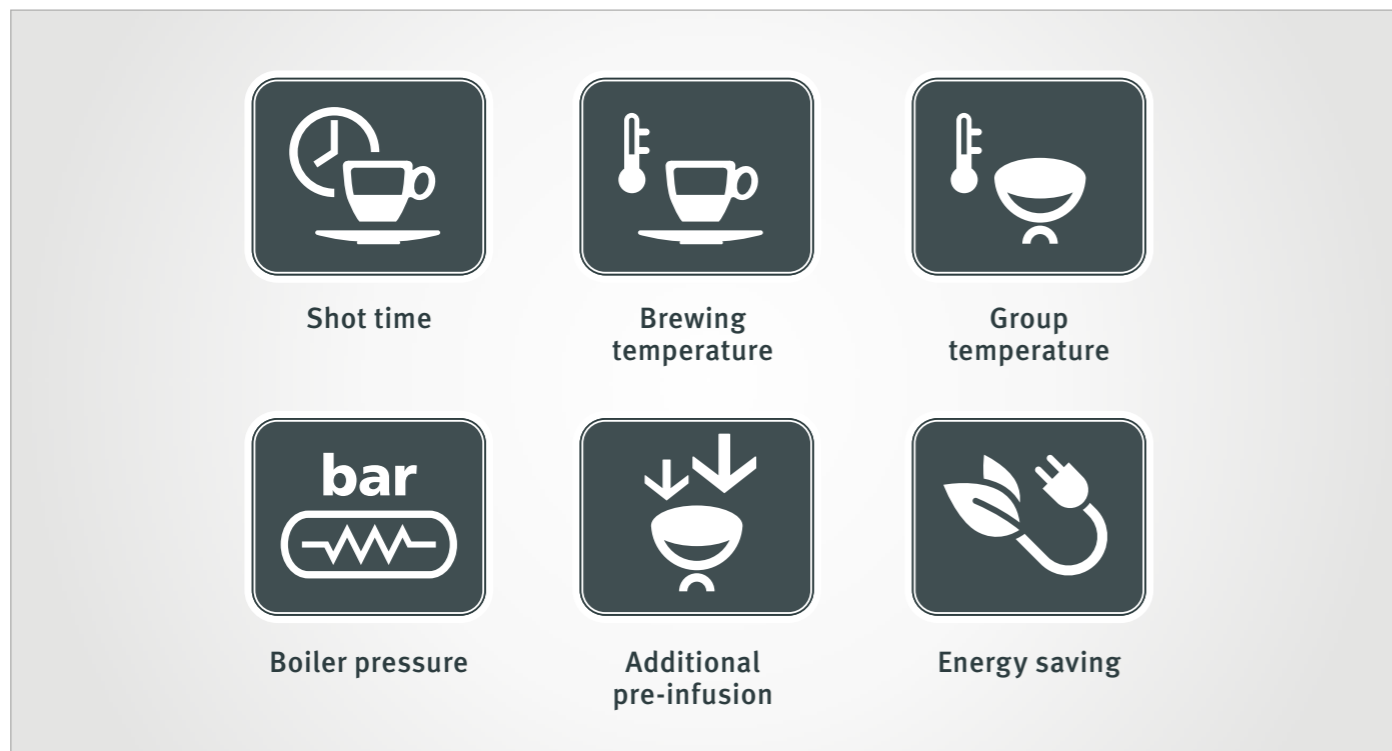

### Smart functions

**IT** Tante utili funzione elettroniche disponibili con la nuova centralina che equipaggia le versioni *Digit* e **T3**: daily on-off programmabile, autodiagnosi, doppio conteggio erogazioni, programmazione allarmi, PID, funzione Energy Saving, gestione scaldatazze, gestione autosteam, ... sono solo alcune delle funzioni che la rendono semplice e intelligente.

**EN** Many useful features are available with the electronic control unit in the new *Digit* and **T3** versions: programmable daily on-off, self-diagnosis, double counting, programmable alarms, PID, Energy Saving function, cup warmer management, Autosteam management, ... are just some of the features that make it simple and smart.

**FR** Aurelia II offre de nombreuses fonctions électroniques, disponibles avec la nouvelle centrale dont sont équipées les versions *Digit* et **T3**: daily on-off programmable, auto-diagnostic, double comptage des extractions, programmation des alarmes, PID, fonction Energy Saving, gestion chauffe-tasses, gestion Autosteam, sont seulement quelques-unes des fonctions qui la rendent simple et intelligente.

**DE** Die neue Steuerung der Ausführungen *Digit* und **T3** bietet zahlreiche, hilfreiche elektronische Funktionen: programmierbares daily on-off, Eigendiagnose, doppelter Zähler, Programmierung des Alarms, PID, Energiesparfunktion, Steuerung Tassenwärmer, Steuerung Autosteam, ... um nur einige der Funktionen zu nennen, dank der diese Maschine einfach und intelligent ist.

**ES** Muchas funciones útiles electrónicas disponibles con la nueva centralita que equipa las versiones *Digit* y **T3**: daily on-off programable, autodiagnóstico, doble cuenta dispensaciones, programación alarmas, PID, función Energy Saving, control calienta tazas, control autosteam ... son sólo algunas de las funciones que la hacen sencilla e inteligente.



### LCD display

**IT** Alla nuova centralina è associato un display grafico TFT con una gestione del menu tramite rotary switch, progettato per includere un'area di informazioni personalizzate per il barista e di diagnostica. Il nuovo display TFT consente al barista di settare e/o monitorare i parametri di erogazione:

- Shot time
- Brewing temperature – **T3**
- Group temperature – **T3**
- Boiler pressure
- Additional pre-infusion
- Energy saving

**EN** The new unit has a TFT graphic display with rotary switch menu management. In addition to displaying diagnostics, barista information can be customized. The new TFT display means the barista can set and/or monitor the output parameters:

- Shot time
- Brewing temperature – **T3**
- Group temperature – **T3**
- Boiler pressure
- Additional pre-infusion
- Energy saving

**FR** Un afficheur graphique TFT a été associé à la nouvelle centrale avec une gestion du menu à travers interrupteur rotatif, conçu pour inclure une zone d'informations personnalisées et de diagnostic pour le barman. Le nouvel afficheur TFT permet au barman de régler et/ou de contrôler les paramètres de distribution:

- Shot time
- Brewing temperature – **T3**
- Group temperature – **T3**
- Boiler pressure
- Additional pre-infusion
- Energy saving

**DE** Die neue Steuerung wurde mit einem grafischen TFT-Display verbunden, das mit einem Rotary-Switch zur Auswahl des Menüs ausgestattet ist, wodurch ein Bereich mit personalisierten Informationen zur Diagnose für den Bediener angelegt wurde. Das neue TFT-Display gestattet dem Bediener die Einstellung bzw. die Überwachung der Ausgabe-Parameter:

- Shot time
- Brewing temperature – **T3**
- Group temperature – **T3**
- Boiler pressure
- Additional pre-infusion
- Energy saving

**ES** La Nueva centralista está conectada a una pantalla electrónica gráfica TFT que permite nevar por medio de un rotary switch y así brindar informaciones y diagnósticos personalizados al barista. La nueva pantalla electrónica TFT permite al barista ajustar y/o controlar los parámetros de dispensación:

- Shot time
- Brewing temperature – **T3**
- Group temperature – **T3**
- Boiler pressure
- Additional pre-infusion
- Energy saving

# T3

## La nuova dimensione della qualità

**IT** Aurelia Competizione incorpora l'innovativa tecnologia T3 che è stata sviluppata dalla Nuova Simonelli facendo tesoro delle ricerche scientifiche effettuate presso prestigiosi centri universitari, dell'esperienza maturata nei campionati del World Barista Championship e soprattutto della collaborazione intercorsa con i baristi campioni del WBC. Aurelia II stabilisce nuovi standards di riferimento in termini di precisione, affidabilità e flessibilità delle prestazioni.

## The new dimension of quality

**EN** Aurelia Competition incorporates innovative T3 technology, developed by Nuova Simonelli taking advantage of scientific research from prestigious universities, experience with the World Barista Championship and above all work with WBC championship baristas Aurelia II sets new standards of reference in terms of precision, reliability and performance flexibility.

## La nouvelle dimension de la qualité

**FR** Aurelia Competizione incorpore la nouvelle technologie T3 qui a été développée par Nuova Simonelli grâce aux recherches scientifiques effectuées auprès de centres universitaires prestigieux, à l'expérience acquise lors des championnats du World Barista Championship et surtout grâce à la collaboration avec les baristas vainqueurs du WBC. Aurelia II établit donc de nouveaux standards de référence en termes de précision, de fiabilité et de flexibilité des performances.

## Die neue Dimension der Espresso-Qualität

**DE** Aurelia Competizione beinhaltet die innovative Technologie T3, die von Nuova Simonelli aufgrund wissenschaftlicher Studien bei angesehenen Universitäten, der bei den Meisterschaften der World Barista Championship gesammelten Erfahrung und insbesondere aufgrund der Zusammenarbeit mit den Meister-Baristas des WBC entwickelt wurde. Aurelia II setzt neue Standards im Hinblick auf Präzision, Zuverlässigkeit und Flexibilität der Leistungen.

## La nueva dimensión de la calidad

**ES** Aurelia Competizione incorpora la innovadora tecnología T3 que ha desarrollado la Nuova Simonelli haciendo tesoro de las investigaciones científicas efectuadas en prestigiosos centros universitarios, con experiencia desarrollada en los campeonatos del World Barista Championship y sobretodo con la colaboración compartida con los baristas campeones del WBC. Aurelia II establece nuevos estándares de referencia en términos de precisión, fiabilidad y flexibilidad de los rendimientos.

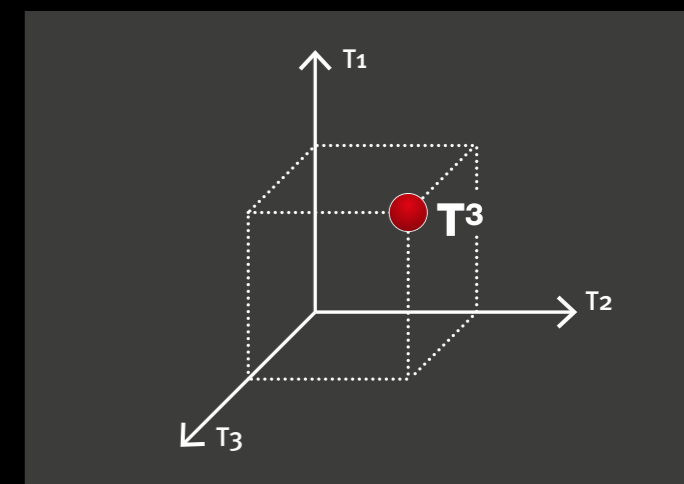
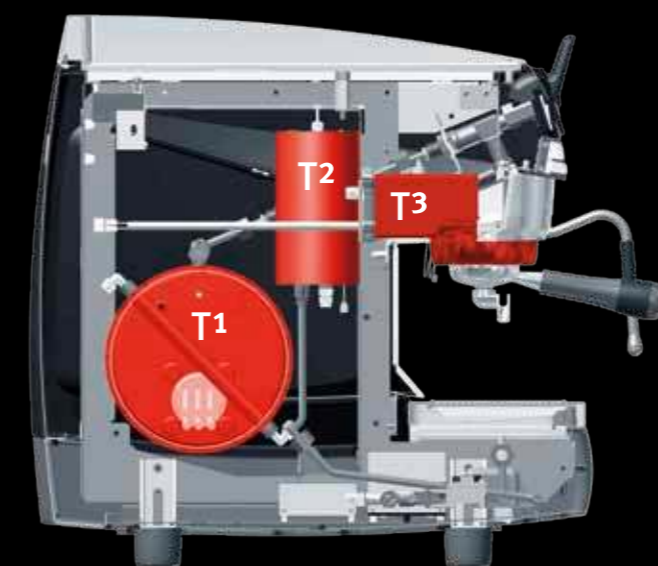

**IT** La tecnologia T3 garantisce performance ancora più evolute, perché effettua su ogni gruppo un controllo tridimensionale della temperatura. La lettura e la gestione diventano così particolarmente accurate. Associata ad una reattività in tempo reale della macchina, garantisce una straordinaria capacità di adattarsi perfettamente alle peculiarità di ogni miscela di caffè.

**EN** The T3 technology provides even more advanced performance, because on each group there is three-dimensional temperature control. So reading and operating become very accurate. Coupled with a real-time responsiveness of the machine, is the guarantee of an extraordinary ability to perfectly adapt to the characteristics of each coffee blend.

**FR** La technologie T3 garantit des performances encore plus évoluées car elle effectue un contrôle tridimensionnel de la température sur chaque groupe. La lecture et la gestion deviennent ainsi particulièrement précises. Associée à une réactivité en temps réel de la machine, elle garantit une capacité extraordinaire de s'adapter parfaitement aux caractéristiques de chaque mélange de café.

**DE** Die Technologie T3 gewährleistet noch fortschrittlichere Leistungen, da sie an jeder Brühgruppe eine dreidimensionale Kontrolle der Temperatur ausführt. Erfassung und Steuerung werden dadurch noch genauer. In Verbindung mit der ungemein hohen Reaktionsgeschwindigkeit der Maschine gewährleistet sie eine außerordentliche Fähigkeit, sich perfekt den Besonderheiten jeder Kaffeemischung anzupassen.

**ES** La tecnología T3 garantiza rendimientos todavía más avanzados, porque efectúa en cada grupo un control tridimensional de la temperatura. La lectura y la administración de esta manera son especialmente precisas. Asociada a una reactividad en tiempo real de la máquina, garantiza una extraordinaria capacidad para adaptarse perfectamente a las peculiaridades de cada mezcla de café.



### Pressure adjustment

**IT** Con Aurelia II **T3** anche la regolazione della pressione pompa è agevolata. Il barista può così agire direttamente, senza dover aprire la macchina o chiamare il tecnico di fiducia, per adattare la pressione alle sue esigenze.

**EN** With Aurelia II **T3** the pump pressure can also be adjusted. The barista can do so directly, without having to unlock the machine or call a trusted technician, to adapt the pressure to his needs.

**FR** Avec Aurelia II **T3**, même le réglage de la pression pompe est simplifié. Le barman peut ainsi agir directement, sans devoir ouvrir la machine ou appeler son technicien habituel, pour adapter la pression à ses exigences.

**DE** Bei Aurelia II **T3** ist auch der Pumpendruck leichter zu regeln. Der Barista kann den Druck direkt seinen Bedürfnissen anpassen, ohne die Maschine öffnen oder seinen Fachtechniker rufen zu müssen.

**ES** Con Aurelia II **T3** también la regulación de la presión de la bomba está facilitada. El barista puede de esta manera actuar directamente, sin tener que abrir la máquina o llamar al técnico de confianza, para adaptar la presión a sus exigencias.



### Thermal insulation

**IT** Prestazioni eccellenti e bassi consumi non sono obiettivi incompatibili per Aurelia II **T3**. Ogni parte del sistema idraulico è isolato termicamente con materiale tecnico per garantire massima costanza e minima dispersione energetica. Attraverso l'elettronica puoi spegnere uno o più gruppi nelle fasi di minor lavoro, abbattendo ulteriormente i consumi.

**EN** Excellent performance and low energy use are not mutually exclusive goals for Aurelia II **T3**. Each part of the hydraulic system is thermally insulated with technical material to ensure maximum consistency and minimum energy loss. Through the electronics one or more groups can be turned off in low workload phases, further reducing energy use.

**FR** Les performances excellentes et l'économie d'énergie ne sont pas des objectifs incompatibles avec Aurelia II **T3**. Chaque partie du système hydraulique est isolé thermiquement avec un matériel technique afin de garantir une constance maximum et une moindre dispersion d'énergie. A travers l'électronique, vous pouvez éteindre un ou plusieurs groupes pendant les phases de travail plus légère, en réduisant ainsi les consommations d'énergie.

**DE** Exzellente Leistungen und niedriger Verbrauch sind Ziele, die bei Aurelia II **T3** durchaus nicht im Widerspruch stehen. Jeder Teil des Hydrauliksystems ist durch technisches Material thermisch isoliert, um höchste Gleichmäßigkeit und minimale Energieverschwendung zu gewährleisten. Dank der Elektronik können in Zeiträumen mit weniger Kundenzulauf eine oder mehrere Brühgruppen abgeschaltet werden, so dass der Energieverbrauch noch zusätzlich gesenkt wird.

**ES** Rendimientos excelentes y bajos consumos no son objetivos incompatibles para Aurelia II **T3**. Cada parte del sistema hidráulico está aislado térmicamente con material técnico para garantizar la máxima constancia y la mínima dispersión energética. A través de la electrónica se pueden apagar uno o varios grupos en las fases de menor trabajo, abatiendo ulteriormente los consumos.



### Steam stop valve

**IT** Fare manutenzione del sistema vapore senza dover arrestare il funzionamento della macchina è il sogno di tanti baristi e tecnici. Con Aurelia II **T3** ora si può. Ogni lancia è equipaggiata di una valvola che consente di interrompere il passaggio del vapore. Si può così intervenire sulla lancia mentre si servono cappuccinos ai clienti.

**EN** Maintaining the steam system without stopping the machine functioning is the dream of many baristas and technicians. With Aurelia II **T3** you now can. Each nozzle is equipped with a valve which can block steam. So you can maintain the nozzle while still serving cappuccinos to customers.

**FR** Effectuer l'entretien du système vapeur sans devoir interrompre le fonctionnement de la machine est le rêve de tous les barmans et de tous les techniciens. Avec Aurelia II **T3**, cela est maintenant possible. Chaque buse vapeur est équipée d'une soupape qui permet d'interrompre le passage du vapeur. On peut ainsi intervenir sur la buse vapeur pendant qu'on sert des cappuccinos aux clients.

**DE** Die Wartung des Dampfsystems ohne Unterbrechung des Maschinenbetriebs ist der Traum vieler Baristas und Techniker. Mit Aurelia II **T3** ist es möglich. Jedes Dampfrohr ist mit einem Ventil ausgestattet, das die Unterbrechung des Dampfes ermöglicht. Das Dampfrohr kann also nach Belieben benutzt werden, wenn den Kunden Cappuccino serviert werden soll.

**ES** Hace el mantenimiento del sistema vapor sin tener que detener el funcionamiento de la máquina es el sueño de tantos baristas y técnicos. Con Aurelia II **T3** ahora se puede. Cada boquilla está equipada con una válvula que permite interrumpir el pasaje del vapor. Se puede de esta manera intervenir en la boquilla mientras se sirven capuchinos a los clientes.



### Teflon filter holder

**IT** Aurelia II **T3** è equipaggiata dei particolari portafiltri con rivestimento in teflon che offre maggiore pulizia e quindi preserva l'aroma del caffè in tazza. Su richiesta si può avere anche il sistema *easy clean* che garantisce lo smontaggio agevolato dei beccchi erogazione.

**EN** Aurelia II **T3** is equipped with the special teflon coated holder that offers greater cleanliness and thus preserves the aroma of coffee in the cup. The *easy clean* system is also available on demand. It ensures simple removal of the delivery nozzles.

**FR** Aurelia II **T3** est équipée de porte-filtres spéciaux revêtus de téflon qui offre une majeure hygiène et qui préserve donc l'arome du café dans la tasse. Il est possible également, sur demande, de munir la machine du système *easy clean* qui garantit le démontage aisé des becs d'extraction.

**DE** Aurelia II **T3** ist mit speziellen, teflonbeschichteten Siebhaltern ausgestattet, die bessere Sauberkeit bieten und somit das Aroma des Kaffees wahren. Auf Wunsch ist auch das System *easy clean* lieferbar, das ein besonders bequemes Abmontieren der Ausgusschnäbel ermöglicht.

**ES** Aurelia II **T3** está equipada con los especiales portafiltras con revestimiento en teflón que ofrece mayor limpieza y por lo tanto preserva el aroma del café en la taza. Bajo petición se puede tener también el sistema *easy clean* que garantiza el desmontaje facilitado de las boquillas de dispensación.

# Aurelia II

## T3

### IT Dedicata a:

- Baristi campioni
- Baristi super-professionisti
- Locali che propongono caffè diversi
- Locali focalizzati sulla qualità del caffè

### EN Dedicated to:

- Champion baristas
- Super professional baristas
- Shops that offer a variety coffees
- Shops focused on coffee quality

### FR Dédié à:

- Barmans vainqueurs
- Barmans super-professionnels
- Etablissements qui offrent un vaste choix de café
- Etablissements focalisés sur la qualité du café

### DE Speziell für:

- Meister-Baristas
- Superprofessionelle Baristas
- Lokale, die eine große Auswahl an Kaffee bieten
- Lokale, die sich auf die Qualität des Kaffees konzentrieren

### ES Dedicada a:

- Baristas campeones
- Baristas súper profesionales
- Locales que ofrecen una variedad de café
- Locales focalizados sobre la calidad del café

Aurelia II T3 – 3 groups



### Standard

- Reverse mirror
- Milk light
- Led light
- Cool touch
- PID
- SIS
- Automatic cleaning

### Optional

- Smart functions
- LCD display
- Pressure adjustment
- Thermal insulation
- Steam stop valve
- Teflon filter holder
- Easy Cream
- Leather filter holder
- Cup warmer

Aurelia II T3  
2 groups



# Aurelia II Digit

## IT Dedicata a:

- Professionisti esigenti
- Catene coffee shops
- Locali con elevate performance qualitative
- Locali alto vendenti

## EN Dedicated to:

- Demanding professionals
- Coffee shop chains
- Shops with high quality performance
- High turnover shops

## FR Dédié à:

- Professionnels exigeants
- Chaînes Coffee shops
- Etablissements avec hautes performances qualitatives
- Etablissements à grands volumes de vente

## DE Speziell für:

- Anspruchsvolle Profis
- Coffeshop-Ketten
- Lokale mit hohen Qualitätsansprüchen
- Lokale mit hohen Verkaufszahlen

## ES Dedicada a:

- Profesionales exigentes
- Cadenas Coffee shops
- Locales con elevados rendimientos cualitativos
- Locales con altas ventas



Aurelia II Digit

### Standard

- Reverse mirror
- PID
- SIS
- Automatic cleaning
- Smart functions
- LCD display

### Optional

- Easy Cream
- Cool touch
- Milk light
- Led light
- Raised groups
- Teflon filter holder
- Leather filter holder
- Cup warmer

Aurelia II Digit  
2 groups + Easy Cream



# Aurelia II

## S Semiautomatic

## V Volumetric

### IT Dedicata a:

- Professionisti esigenti ma attenti al costo
- Locali alto-medio vendenti
- Locali con medio-alto esigenze qualitative

### EN Dedicated to:

- Demanding Professionals in terms of quality and cost
- Medium-high turnover shops
- Medium-high quality performance shops

### FR Dédié à:

- Professionnels exigeants en termes de qualité et de coût
- Etablissements à moyens/hauts volumes de vente
- Etablissements à moyennes/hautes performances qualitatives de vente

### DE Speziell für:

- Anspruchsvolle Profis im Hinblick auf Qualität und Kosten
- Lokale mit mittleren bis hohen Verkaufszahlen
- Lokale mit mittlerer bis hoher Leistungsqualität

### ES Dedicada a:

- Profesionales exigentes en términos de calidad y de coste
- Locales de ventas medio-altas
- Locales con rendimientos cualitativos medio-altos



Aurelia II V – 2 groups (raised, on the left) and Aurelia II S – 3 groups (on the right)

### Standard

- Reverse mirror
- SIS
- Automatic cleaning (Volumetric)

### Optional

- Easy Cream (Volumetric)
- Cool touch
- Milk light
- Led light
- Raised groups
- Teflon filter holder
- Leather filter holder
- Cup warmer



Aurelia II S – 4 groups (raised)

## Aurelia II T<sup>3</sup>

2 GR

S



V



3 GR

S



3 GR

V



## Aurelia II Digit

2 GR



3 GR



4 GR



## Aurelia II S ☞ Semiautomatic

2 GR



3 GR



4 GR



## Aurelia II V ☞ Volumetric

2 GR



3 GR



4 GR



# AURELIA II

La migliore Aurelia di sempre  
The best Aurelia of all times



nuova  
**SIMONELLI**  
espresso coffee machines

La Nuova Simonelli si riserva il diritto di modificare senza preavviso le caratteristiche delle apparecchiature trattate in questa pubblicazione.

Nuova Simonelli reserves the right to modify the appliances presented in this publication without notice.

Versione / Version		2 gr					3 gr					4 gr		
Modello / Model		S	V	Digit	T <sup>3</sup> S	T <sup>3</sup> V	S	V	Digit	T <sup>3</sup> S	T <sup>3</sup> V	S	V	Digit
Carrozzeria Body	Materiale Material	Acciaio inox con inserti in ABS / Stainless Steel with ABS insert										Acciaio inox con inserti in ABS / Stainless Steel with ABS insert		
	Colori standard Colours	<input type="checkbox"/> Nero / Black <input type="checkbox"/> Bianco perla / Pearl white <input type="checkbox"/> Rosso / Red										<input type="checkbox"/> Nero / Black <input type="checkbox"/> Bianco perla / Pearl white <input type="checkbox"/> Rosso / Red		
Caldia Boiler	Kit Led completo Full LED light kit	<input type="checkbox"/>	<input type="checkbox"/>	<input type="checkbox"/>	<input type="checkbox"/>	<input type="checkbox"/>	<input type="checkbox"/>	<input type="checkbox"/>	<input type="checkbox"/>	<input type="checkbox"/>	<input type="checkbox"/>	<input type="checkbox"/>	<input type="checkbox"/>	<input type="checkbox"/>
	Capacità Boiler capacity	14 lt	14 lt	14 lt	14 lt	14 lt	17 lt	17 lt	17 lt	17 lt	17 lt	22 lt	22 lt	22 lt
	Materiale Material	Rame / Copper	Rame / Copper	Rame / Copper	Rame / Copper	Rame / Copper	Rame / Copper	Rame / Copper	Rame / Copper	Rame / Copper	Rame / Copper	Rame / Copper	Rame / Copper	Rame / Copper
	Valvola sicurezza Security Valve	<input type="checkbox"/>	<input type="checkbox"/>	<input type="checkbox"/>	<input type="checkbox"/>	<input type="checkbox"/>	<input type="checkbox"/>	<input type="checkbox"/>	<input type="checkbox"/>	<input type="checkbox"/>	<input type="checkbox"/>	<input type="checkbox"/>	<input type="checkbox"/>	<input type="checkbox"/>
	Valvola antirisucchio No-vacuum valve	<input type="checkbox"/>	<input type="checkbox"/>	<input type="checkbox"/>	<input type="checkbox"/>	<input type="checkbox"/>	<input type="checkbox"/>	<input type="checkbox"/>	<input type="checkbox"/>	<input type="checkbox"/>	<input type="checkbox"/>	<input type="checkbox"/>	<input type="checkbox"/>	<input type="checkbox"/>
	Pressostato Pressostat	Manual	Manual	Digital	Digital	Digital	Manual	Manual	Digital	Digital	Digital	Manual	Manual	Digital
Idraulica Hydraulics	Autolivello elettronico Automatic water flow	<input type="checkbox"/>	<input type="checkbox"/>	<input type="checkbox"/>	<input type="checkbox"/>	<input type="checkbox"/>	<input type="checkbox"/>	<input type="checkbox"/>	<input type="checkbox"/>	<input type="checkbox"/>	<input type="checkbox"/>	<input type="checkbox"/>	<input type="checkbox"/>	<input type="checkbox"/>
	Pompa volumetrica Volumetric pump	<input type="checkbox"/>	<input type="checkbox"/>	<input type="checkbox"/>	<input type="checkbox"/>	<input type="checkbox"/>	<input type="checkbox"/>	<input type="checkbox"/>	<input type="checkbox"/>	<input type="checkbox"/>	<input type="checkbox"/>	<input type="checkbox"/>	<input type="checkbox"/>	<input type="checkbox"/>
	Regol. esterna pompa External pump adjustm.	<input type="checkbox"/>	<input type="checkbox"/>	<input type="checkbox"/>	<input type="checkbox"/>	<input type="checkbox"/>	<input type="checkbox"/>	<input type="checkbox"/>	<input type="checkbox"/>	<input type="checkbox"/>	<input type="checkbox"/>	<input type="checkbox"/>	<input type="checkbox"/>	<input type="checkbox"/>
	Dosatura volumetrica Volumetric dosage	<input type="checkbox"/>	<input type="checkbox"/>	<input type="checkbox"/>	<input type="checkbox"/>	<input type="checkbox"/>	<input type="checkbox"/>	<input type="checkbox"/>	<input type="checkbox"/>	<input type="checkbox"/>	<input type="checkbox"/>	<input type="checkbox"/>	<input type="checkbox"/>	<input type="checkbox"/>
	Manometro (bar pompa) Gauge (bar pump)	<input type="checkbox"/>	<input type="checkbox"/>	<input type="checkbox"/>	<input type="checkbox"/>	<input type="checkbox"/>	<input type="checkbox"/>	<input type="checkbox"/>	<input type="checkbox"/>	<input type="checkbox"/>	<input type="checkbox"/>	<input type="checkbox"/>	<input type="checkbox"/>	<input type="checkbox"/>
	Manometro caldaia Gauge (boiler)	<input type="checkbox"/>	<input type="checkbox"/>	Electronic	Electronic	Electronic	<input type="checkbox"/>	<input type="checkbox"/>	Electronic	Electronic	Electronic	<input type="checkbox"/>	<input type="checkbox"/>	Electronic
	Indicatore livello acqua Water level indicator	<input type="checkbox"/>	<input type="checkbox"/>	<input type="checkbox"/>	<input type="checkbox"/>	<input type="checkbox"/>	<input type="checkbox"/>	<input type="checkbox"/>	<input type="checkbox"/>	<input type="checkbox"/>	<input type="checkbox"/>	<input type="checkbox"/>	<input type="checkbox"/>	<input type="checkbox"/>
	Reg. temp. gruppo Group temp. adjustm.	Termosifonic	Termosifonic	Termosifonic	Electronic	Electronic	Termosifonic	Termosifonic	Termosifonic	Electronic	Electronic	Termosifonic	Termosifonic	Termosifonic
	Infusione SIS Soft infusion system (SIS)	<input type="checkbox"/>	<input type="checkbox"/>	<input type="checkbox"/>	<input type="checkbox"/>	<input type="checkbox"/>	<input type="checkbox"/>	<input type="checkbox"/>	<input type="checkbox"/>	<input type="checkbox"/>	<input type="checkbox"/>	<input type="checkbox"/>	<input type="checkbox"/>	<input type="checkbox"/>
	N. stabilizzatori gruppo N. group stabilisers				2	2				3	3			
	Capacità stabilizz. gruppo Group stabiliser capacity				1	1				1	1			
	Gruppi altezza maggiorata Raised groups	<input type="checkbox"/>	<input type="checkbox"/>	<input type="checkbox"/>	<input type="checkbox"/>	<input type="checkbox"/>	<input type="checkbox"/>	<input type="checkbox"/>	<input type="checkbox"/>	<input type="checkbox"/>	<input type="checkbox"/>	<input type="checkbox"/>	<input type="checkbox"/>	<input type="checkbox"/>
	Portafiltro teflonato Teflon filter holder	<input type="checkbox"/>	<input type="checkbox"/>	<input type="checkbox"/>	<input type="checkbox"/>	<input type="checkbox"/>	<input type="checkbox"/>	<input type="checkbox"/>	<input type="checkbox"/>	<input type="checkbox"/>	<input type="checkbox"/>	<input type="checkbox"/>	<input type="checkbox"/>	<input type="checkbox"/>
	Portafiltro pelle + teflon Filter holder leather + teflon	<input type="checkbox"/>	<input type="checkbox"/>	<input type="checkbox"/>	<input type="checkbox"/>	<input type="checkbox"/>	<input type="checkbox"/>	<input type="checkbox"/>	<input type="checkbox"/>	<input type="checkbox"/>	<input type="checkbox"/>	<input type="checkbox"/>	<input type="checkbox"/>	<input type="checkbox"/>
	Padiglione teflonato Teflon pavillon	<input type="checkbox"/>	<input type="checkbox"/>	<input type="checkbox"/>	<input type="checkbox"/>	<input type="checkbox"/>	<input type="checkbox"/>	<input type="checkbox"/>	<input type="checkbox"/>	<input type="checkbox"/>	<input type="checkbox"/>	<input type="checkbox"/>	<input type="checkbox"/>	<input type="checkbox"/>
	Becco easy clean Easy clean spout	<input type="checkbox"/>	<input type="checkbox"/>	<input type="checkbox"/>	<input type="checkbox"/>	<input type="checkbox"/>	<input type="checkbox"/>	<input type="checkbox"/>	<input type="checkbox"/>	<input type="checkbox"/>	<input type="checkbox"/>	<input type="checkbox"/>	<input type="checkbox"/>	<input type="checkbox"/>
Vapore Steam	N. lance vapore N. steam wands	2	2	2	2	2	2	2	2	2	2	2	2	2
	Acciaio inox Stainless steel	<input type="checkbox"/>	<input type="checkbox"/>	<input type="checkbox"/>	<input type="checkbox"/>	<input type="checkbox"/>	<input type="checkbox"/>	<input type="checkbox"/>	<input type="checkbox"/>	<input type="checkbox"/>	<input type="checkbox"/>	<input type="checkbox"/>	<input type="checkbox"/>	<input type="checkbox"/>
	Lancia cool touch Cool touch wand	<input type="checkbox"/>	<input type="checkbox"/>	<input type="checkbox"/>	<input type="checkbox"/>	<input type="checkbox"/>	<input type="checkbox"/>	<input type="checkbox"/>	<input type="checkbox"/>	<input type="checkbox"/>	<input type="checkbox"/>	<input type="checkbox"/>	<input type="checkbox"/>	<input type="checkbox"/>
	Easy Cream singolo Single Easy Cream	<input type="checkbox"/>	<input type="checkbox"/>	<input type="checkbox"/>	<input type="checkbox"/>	<input type="checkbox"/>	<input type="checkbox"/>	<input type="checkbox"/>	<input type="checkbox"/>	<input type="checkbox"/>	<input type="checkbox"/>	<input type="checkbox"/>	<input type="checkbox"/>	<input type="checkbox"/>
	Easy Cream doppio Double Easy Cream	<input type="checkbox"/>	<input type="checkbox"/>	<input type="checkbox"/>	<input type="checkbox"/>	<input type="checkbox"/>	<input type="checkbox"/>	<input type="checkbox"/>	<input type="checkbox"/>	<input type="checkbox"/>	<input type="checkbox"/>	<input type="checkbox"/>	<input type="checkbox"/>	<input type="checkbox"/>
	N. lance N. lance	1	1	1	1	1	1	1	1	1	1	1	1	1
Acqua calda Hot water	Economizzatore acqua calda Hot water economiser	<input type="checkbox"/>	<input type="checkbox"/>	<input type="checkbox"/>	<input type="checkbox"/>	<input type="checkbox"/>	<input type="checkbox"/>	<input type="checkbox"/>	<input type="checkbox"/>	<input type="checkbox"/>	<input type="checkbox"/>	<input type="checkbox"/>	<input type="checkbox"/>	<input type="checkbox"/>
	Dosatura acqua calda Hot water dosage	<input type="checkbox"/>	<input type="checkbox"/>	<input type="checkbox"/>	<input type="checkbox"/>	<input type="checkbox"/>	<input type="checkbox"/>	<input type="checkbox"/>	<input type="checkbox"/>	<input type="checkbox"/>	<input type="checkbox"/>	<input type="checkbox"/>	<input type="checkbox"/>	<input type="checkbox"/>
Scaldacoppie Cup warmer	Elettrico On/Off On/Off electric	<input type="checkbox"/>	<input type="checkbox"/>	<input type="checkbox"/>	<input type="checkbox"/>	<input type="checkbox"/>	<input type="checkbox"/>	<input type="checkbox"/>	<input type="checkbox"/>	<input type="checkbox"/>	<input type="checkbox"/>	<input type="checkbox"/>	<input type="checkbox"/>	<input type="checkbox"/>
	Temp. programmabile Programmable temp.	<input type="checkbox"/>	<input type="checkbox"/>	<input type="checkbox"/>	<input type="checkbox"/>	<input type="checkbox"/>	<input type="checkbox"/>	<input type="checkbox"/>	<input type="checkbox"/>	<input type="checkbox"/>	<input type="checkbox"/>	<input type="checkbox"/>	<input type="checkbox"/>	<input type="checkbox"/>
Elettronica Electronic	Display TFT Display TFT	<input type="checkbox"/>	<input type="checkbox"/>	<input type="checkbox"/>	<input type="checkbox"/>	<input type="checkbox"/>	<input type="checkbox"/>	<input type="checkbox"/>	<input type="checkbox"/>	<input type="checkbox"/>	<input type="checkbox"/>	<input type="checkbox"/>	<input type="checkbox"/>	<input type="checkbox"/>
	On/Off On/Off	<input type="checkbox"/>	<input type="checkbox"/>	<input type="checkbox"/>	<input type="checkbox"/>	<input type="checkbox"/>	<input type="checkbox"/>	<input type="checkbox"/>	<input type="checkbox"/>	<input type="checkbox"/>	<input type="checkbox"/>	<input type="checkbox"/>	<input type="checkbox"/>	<input type="checkbox"/>
	Conteggio totale/parziale Partial/total Counter	<input type="checkbox"/>	<input type="checkbox"/>	<input type="checkbox"/>	<input type="checkbox"/>	<input type="checkbox"/>	<input type="checkbox"/>	<input type="checkbox"/>	<input type="checkbox"/>	<input type="checkbox"/>	<input type="checkbox"/>	<input type="checkbox"/>	<input type="checkbox"/>	<input type="checkbox"/>
	Autodiagnosi Check control	<input type="checkbox"/>	<input type="checkbox"/>	<input type="checkbox"/>	<input type="checkbox"/>	<input type="checkbox"/>	<input type="checkbox"/>	<input type="checkbox"/>	<input type="checkbox"/>	<input type="checkbox"/>	<input type="checkbox"/>	<input type="checkbox"/>	<input type="checkbox"/>	<input type="checkbox"/>
	Lavaggio autom. Autom. cleaning program	<input type="checkbox"/>	<input type="checkbox"/>	<input type="checkbox"/>	<input type="checkbox"/>	<input type="checkbox"/>	<input type="checkbox"/>	<input type="checkbox"/>	<input type="checkbox"/>	<input type="checkbox"/>	<input type="checkbox"/>	<input type="checkbox"/>	<input type="checkbox"/>	<input type="checkbox"/>
	Tempo erogazione Shot time	<input type="checkbox"/>	<input type="checkbox"/>	<input type="checkbox"/>	<input type="checkbox"/>	<input type="checkbox"/>	<input type="checkbox"/>	<input type="checkbox"/>	<input type="checkbox"/>	<input type="checkbox"/>	<input type="checkbox"/>	<input type="checkbox"/>	<input type="checkbox"/>	<input type="checkbox"/>
	Temp./press. caldaia Temp./press. boiler	<input type="checkbox"/>	<input type="checkbox"/>	<input type="checkbox"/>	<input type="checkbox"/>	<input type="checkbox"/>	<input type="checkbox"/>	<input type="checkbox"/>	<input type="checkbox"/>	<input type="checkbox"/>	<input type="checkbox"/>	<input type="checkbox"/>	<input type="checkbox"/>	<input type="checkbox"/>
	Temp. acqua caffè Brewing water temp.	<input type="checkbox"/>	<input type="checkbox"/>	<input type="checkbox"/>	<input type="checkbox"/>	<input type="checkbox"/>	<input type="checkbox"/>	<input type="checkbox"/>	<input type="checkbox"/>	<input type="checkbox"/>	<input type="checkbox"/>	<input type="checkbox"/>	<input type="checkbox"/>	<input type="checkbox"/>
	Program. temp. acqua caffè Coffee water temp. program	<input type="checkbox"/>	<input type="checkbox"/>	<input type="checkbox"/>	<input type="checkbox"/>	<input type="checkbox"/>	<input type="checkbox"/>	<input type="checkbox"/>	<input type="checkbox"/>	<input type="checkbox"/>	<input type="checkbox"/>	<input type="checkbox"/>	<input type="checkbox"/>	<input type="checkbox"/>
	Program. temp. gruppo Group temp. program	<input type="checkbox"/>	<input type="checkbox"/>	<input type="checkbox"/>	<input type="checkbox"/>	<input type="checkbox"/>	<input type="checkbox"/>	<input type="checkbox"/>	<input type="checkbox"/>	<input type="checkbox"/>	<input type="checkbox"/>	<input type="checkbox"/>	<input type="checkbox"/>	<input type="checkbox"/>
	Program. addolc Water softner program	<input type="checkbox"/>	<input type="checkbox"/>	<input type="checkbox"/>	<input type="checkbox"/>	<input type="checkbox"/>	<input type="checkbox"/>	<input type="checkbox"/>	<input type="checkbox"/>	<input type="checkbox"/>	<input type="checkbox"/>	<input type="checkbox"/>	<input type="checkbox"/>	<input type="checkbox"/>
	Program. manut. Maintenance program	<input type="checkbox"/>	<input type="checkbox"/>	<input type="checkbox"/>	<input type="checkbox"/>	<input type="checkbox"/>	<input type="checkbox"/>	<input type="checkbox"/>	<input type="checkbox"/>	<input type="checkbox"/>	<input type="checkbox"/>	<input type="checkbox"/>	<input type="checkbox"/>	<input type="checkbox"/>
	Program. press. caldaia Boiler pressure. program	<input type="checkbox"/>	<input type="checkbox"/>	<input type="checkbox"/>	<input type="checkbox"/>	<input type="checkbox"/>	<input type="checkbox"/>	<input type="checkbox"/>	<input type="checkbox"/>	<input type="checkbox"/>	<input type="checkbox"/>	<input type="checkbox"/>	<input type="checkbox"/>	<input type="checkbox"/>
	A - Larghezza (mm) A - Width (inch)	815 (32 1/16)	815 (32 1/16)	815 (32 1/16)	815 (32 1/16)	815 (32 1/16)	1045 (41 1/8)	1045 (41 1/8)	1045 (41 1/8)	1045 (41 1/8)	1045 (41 1/8)	1275 (50 3/16)	1275 (50 3/16)	1275 (50 3/16)
Dimensioni Dimension	H - Altezza (mm) H - Height (inch)	565 (22 3/16)	565 (22 3/16)	565 (22 3/16)	565 (22 3/16)	565 (22 3/16)	565 (22 3/16)	565 (22 3/16)	565 (22 3/16)	565 (22 3/16)	565 (22 3/16)	565 (22 3/16)	565 (22 3/16)	565 (22 3/16)
	C - Profondità (mm) C - Depth (inch)	565 (22 3/16)	565 (22 3/16)	565 (22 3/16)	565 (22 3/16)	565 (22 3/16)	565 (22 3/16)	565 (22 3/16)	565 (22 3/16)	565 (22 3/16)	565 (22 3/16)	565 (22 3/16)	565 (22 3/16)	565 (22 3/16)
	B - Larghezza (mm) B - Width (inch)	720 (28 5/16)	720 (28 5/16)	720 (28 5/16)	720 (28 5/16)	720 (28 5/16)	950 (37 3/8)	950 (37 3/8)	950 (37 3/8)	950 (37 3/8)	950 (37 3/8)	1180 (46 7/16)	1180 (46 7/16)	1180 (46 7/16)
	D - Profondità (mm) D - Depth (inch)	370 (14 9/16)	370 (14 9/16)	370 (14 9/16)	370 (14 9/16)	370 (14 9/16)	370 (14 9/16)	370 (14 9/16)	370 (14 9/16)	370 (14 9/16)	370 (14 9/16)	370 (14 9/16)	370 (14 9/16)	370 (14 9/16)
Peso Weight	Peso netto (kg) Net weight (lb)	76 (167)	76 (167)	76 (167)	78 (171)	78 (171)	90 (198)	90 (198)	90 (198)	93 (205)	93 (205)	106 (233)	106 (233)	106 (233)
	Peso lordo (kg) Gross weight (lb)	82 (180)	82 (180)	82 (180)	84 (185)	84 (185)	100 (220)	100 (220)	100 (220)	103 (227)	103 (227)	122 (268)	122 (268)	122 (268)
Potenza Power	Voltaggio Voltage	230 - 380V	230 - 380V	230 - 380V	230 - 380V	230 - 380V	230 - 380V	230 - 380V	230 - 380V	230 - 380V	230 - 380V	230 - 380V	230 - 380V	230 - 380V
	Potenza massima Maximum power	4500W	4500W	4500W	7300W	7300W	5200W	5200W	5200W	9100W	9100W	5200W	5200W	5200W
Suggerimenti Installazione / Hint installation														
Piano Macchina	Larghezza min. Minimum width	1100 (43 1/4)	1100 (43 1/4)	1100 (43 1/4)	1100 (43 1/4)	1100 (43 1/4)	1300 (51 1/8)	1300 (51 1/8)	1300 (51 1/8)	1300 (51 1/8)	1300 (51 1/8)	1550 (61)	1550 (61)	1550 (61)
	Profondità sugg. (mm) Depth (inch)	600 (23 9/16)	600 (23 9/16)	600 (23 9/16)	600 (23 9/16)	600 (23 9/16)	600 (23 9/16)	600 (23 9/16)	600 (23 9/16)	600 (23 9/16)	600 (23 9/16)	600 (23 9/16)	600 (23 9/16)	600 (23 9/16)
	Altezza sugg. (mm) Height (inch)	1040 (40 15/16)	1040 (40 15/16)	1040 (40 15/16)	1040 (40 15/16)	1040 (40 15/16)	1040 (40 15/16)	1040 (40 15/16)	1040 (40 15/16)	1040 (40 15/16)	1040 (40 15/16)	1040 (40 15/16)	1040 (40 15/16)	1040 (40 15/16)
	Diametro foro (mm) Hole diameter (inch)	60 (2 5/16)	60 (2 5/16)	60 (2 5/16)	60 (2 5/16)	60 (2 5/16)	60 (2 5/16)	60 (2 5/16)	60 (2 5/16)	60 (2 5/16)	60 (2 5/16)	60 (2 5/16)	60 (2 5/16)	60 (2 5/16)
Ingr. acqua Water inflow	Dist. max rubinetto (mm) Max dist. from water tap (inch)	1000 (39 5/16)	1000 (39 5/16)	1000 (39 5/16)	1000 (39 5/16)	1000 (39 5/16)	1000 (39 5/16)	1000 (39 5/16)	1000 (39 5/16)	1000 (39 5/16)	1000 (39 5/16)	1000 (39 5/16)	1000 (39 5/16)	1000 (39 5/16)
	Attacco Pipe connection	3/8	3/8	3/8	3/8	3/8	3/8	3/8	3/8	3/8	3/8	3/8	3/8	3/8
Impianto elettr. Wiring	Dist. max prese (mm) Max dist. (inch)	1000 (39 5/16)	1000 (39 5/16)	1000 (39 5/16)	1000 (39 5/16)	1000 (39 5/16)	1000 (39 5/16)	1000 (39 5/16)	1000 (39 5/16)	1000 (39 5/16)	1000 (39 5/16)	1000 (39 5/16)	1000 (39 5/16)	1000 (39 5/16)
	Se impianto 380V If 380V	Trif. con neutro	Trif. con neutro	Trif. con neutro	Trif. con neutro	Trif. con neutro	Trif. con neutro	Trif. con neutro	Trif. con neutro	Trif. con neutro	Trif. con neutro	Trif. con neutro	Trif. con neutro	Trif. con neutro
	Amper macch. Ampere	20	20	20	32	32	23	23	23	40	40	23	23	23

• standard ◦ optional

[www.nuovasimonelli.it](http://www.nuovasimonelli.it)



**Nuova Simonelli S.p.A.**

Via M. D'Antegiano, 6  
62020 Belforte del Chienti  
Macerata Italy  
tel. +39.0733.9501  
fax +39.0733.950242  
videoconf. +39.0733.950201

[www.nuovasimonelli.it](http://www.nuovasimonelli.it)  
[n.simonelli@nuovasimonelli.it](mailto:n.simonelli@nuovasimonelli.it)

**Nuova Distribution USA**

6940 Salashan PKWY BLDG A  
Ferndale, WA 98248  
tel. +1.360.3662226  
fax +1.360.3664015  
videoconf. +1.360.3188595

[www.nuovadistribution.com](http://www.nuovadistribution.com)  
[info@nuovadistribution.com](mailto:info@nuovadistribution.com)

