

DIVA



# DIVA

LA NUOVA INTERPRETE DELL'ELEGANZA



DIVA

# LA NUOVA INTERPRETE DELL'ELEGANZA

EN

La ricerca dell'eleganza è, nella moda così come nell'industrial design, un percorso di scoperta di quell'alchimia perfetta di ingredienti che riesce a generare un prodotto emozionante e ricco di fascino. Con la nuova vetrina Diva, Isa rimane fedele a quella filosofia industriale che da oltre 50 anni l'ha resa celebre in tutto il mondo della gelateria e della pasticceria professionale: prodotti non solo efficienti, dalle prestazioni tecnologiche eccellenti e fedeli alleati nel lavoro quotidiano ma anche vere e proprie icone dalla spiccata personalità, con una cura maniacale del dettaglio.

The search for elegance is in fashion as well as in industrial design, a journey of discovery of the perfect combination of ingredients that can generate an exciting and fascinating product. With the new display cabinet Diva, Isa remains loyal to the industrial philosophy that for 50 years has made it famous all over the world of ice cream and professional pastry: these products are not only efficient, high performance and loyal supporters in the daily work but also true icons with a strong personality, characterized by an obsessive attention to details.

THE NEW  
EXPONENT  
OF THE  
ELEGANCE

FR

La recherche de l'élégance dans l'industrial design, est comme un parcours de découverte d'ingrédients qui peuvent générer un produit excitant et fascinant comme dans un'alchimie parfaite. Avec la nouvelle vitrine Diva, Isa reste fidèle à la philosophie industrielle qui depuis 50 ans l'a rendu célèbre dans le monde de la crème glacée et de la pâtisserie professionnel : produits efficaces avec excellente performances technologiques, et fidèles alliés dans le travail quotidien, mais aussi de véritables icônes avec une forte personnalité, avec une attention obsessionnelle du détail.

LA NOUVELLE  
INTERPRÊTE  
DE L'ÉLÉGANCE

DE

Die Suche nach Eleganz ist in der Mode sowie im Industriedesign, eine Entdeckungsreise der perfekten Zusammenstellung von Zutaten, die ein spannendes und faszinierendes Produkt generieren kann. Mit der neuen Vitrine Diva bleibt Isa der industriellen Philosophie treu, die seit 50 Jahren es berühmt in der ganzen Welt von Eis und professionellem Gebäck hat. Diese Produkte sind nicht nur effizient, mit hervorragende Leistung und treuen Mitarbeiter in der täglichen Arbeit, sondern auch wahre Symbole, die eine ausgeprägte Individualität sind und durch eine obsessive Liebe zum Detail gekennzeichnet sind.

DER NEUE  
INTERPRET  
DER ELEGANZ

ES

La búsqueda de la elegancia es tanto en la moda como en la industria del diseño un recorrido para descubrir la alquimia perfecta de ingredientes que generan un producto emocionante y lleno de fascinación. Con la nueva vitrina Diva, ISA continúa fiel a la filosofía industrial que la llevó al estrellato del mundo de la heladería y de la pastelería profesional hace ya más de 50 años. Además de productos eficientes, prestaciones tecnológicas excelentes y colaboradores fieles en el trabajo cotidiano, también cuenta con auténticos iconos de marcada personalidad cuidados hasta el último detalle.

LA NUOVA  
INTERPRETE  
DE LA  
ELEGANCIA



ΔΙΔΑ

# DESIGN CONTEMPORANEO

CONTEMPORARY  
DESIGN

DESIGN  
CONTEMPORAIN

ZEITGENÖSSISCHES  
DESIGN

DISEÑO  
CONTEMPORÁNEO





**H125 - H140 / 2 ALTEZZE**  
2 HEIGHTS  
2 HAUTEURS  
2 HÖHEN  
2 ALTURAS

**PIANO DI LAVORO: CORIAN™ GLACIER WHITE**  
COUNTERTOP: CORIAN™ GLACIER WHITE  
PLAN DE TRAVAIL: CORIAN™ GLACIER WHITE  
ARBEITSPLATTE: CORIAN™ GLACIER WHITE  
MOSTRADOR: CORIAN™ GLACIER WHITE

**POSSIBILITÀ DI CANALIZZAZIONE**  
MULTIPLEXING  
POSSIBILITÉ DE CANALISATION  
ZUSAMMENBAU  
POSIBILIDAD DE CANALIZACION

**FIANCHI LATERALI: CORIAN™**  
SIDE PANEL: CORIAN™  
CÔTÉ: CORIAN™  
SEITENVERKLEIDUNG: CORIAN™  
PANEL LATERAL: CORIAN™

**FRONTALE: CORIAN™**  
FRONT PANEL: CORIAN™  
FRONTAL: CORIAN™  
FRONTPANEEL: CORIAN™  
FRONTAL: CORIAN™

**ILLUMINAZIONE INFERIORE RGB**  
RGB BOTTOM LIGHT  
ILLUMINATION INFÉRIEURE RGB  
UNTERE BELEUCHTUNG RGB  
ILUMINACIÓN INFERIOR RGB

ΔIVA

# ESSENZIALE E TECNOLOGICA

EN

Diva è la nuova interprete dell'eleganza secondo Isa: un equilibrio perfetto tra design, estetica e funzionalità che esalta il food appeal del prodotto e dona un tocco di classe all'ambiente di consumo grazie ai volumi che si raccordano in maniera armoniosa, alle ampie superfici trasparenti del castello vetri (senza montanti frontali e con i laterali a ridotto spessore) e alle nuance sobrie e ricercate dei pannelli frontali e laterali.

Diva is the new exponent of the elegance by Isa: a perfect balance between design, aesthetics and functionality that enhances the food appeal of the product and gives a touch of charme to the environment, thanks to the volumes, that fit together in a harmonious way, the wide transparent surfaces of the glass frame (without front pillars and with lateral pillars that have reduced thickness) and thanks to the sober and refined nuances of the front and side panels.

ESSENTIAL  
AND  
TECHNOLOGICAL

FR

Diva est la nouvelle interprète de l'élégance selon Isa: un équilibre parfait entre design, esthétique et fonctionnalité, qui améliore le food appeal du produit et donne une touche de classe à l'environnement, grâce aux volumes qui sont reliés de façon harmonieuse, les grandes surfaces transparentes des verres (sans jambes de force avant et latéraux avec épaisseur réduit) et aux nuances sobres et sophistiquées des panneaux frontaux et latéraux.

ESSENTIEL  
ET TECHNOLOGIE

DE

Diva ist der neue Interpret der Eleganz von Isa: eine perfekte Balance zwischen Design, Ästhetik und Funktionalität, die das Food Appeal des Produkts verbessert und einen Hauch von Charme der Umgebung gibt, dank der Rauminhalte, die sich gegenseitig in einer harmonischen Weise verbinden, dank der großen transparenten Flächen des Glasrahmens (ohne vorderen Pfosten und mit Seitenpfosten, die reduzierter Dicke haben) und dank der nüchternen und raffinierten Nuancen der Frontpaneelen und Seitenpaneelen.

ESSENTIELL  
UND  
TECHNOLOGISCH

ES

Diva es la nueva intérprete de la elegancia según ISA: un equilibrio perfecto entre diseño, estética y funcionalidad que exalta el food appeal del producto y da un toque de clase al ambiente de consumo gracias a los volúmenes que se entremezclan de manera armoniosa y a las amplias superficies de la vitrina transparente (sin soportes frontales y con laterales de bajo espesor) y a los matices sobrios y elaborados de los paneles frontales y laterales.

ESENCIAL  
Y TECNOLÓGICA



DIVA

# DIVA COLORS

DIVA  
COLORS

DIVA  
COULEURS

DIVA  
FARBEN

DIVA  
COLORES



SIDE PANEL

A /  
GRIGIO

B /  
CORIAN™ GLACIER WHITE  
CORIAN™ PEARL GRAY  
CORIAN™ CLAY  
CORIAN™ BISQUE



FRONTAL PANEL

CORIAN™ GLACIER WHITE



CORIAN™ PEARL GRAY





CORIAN™ CLAY



CORIAN™ BISQUE

# H125

# H140

	120	170	120+50 COMBI	220	170+50 COMBI	AE 45
<b>Versioni / Versions</b>						
(VG) Gelato / Gelato	/	/	/	/	/	/
(VP) Pasticceria / Pastry	/	/		/		/
<b>Unità Condensatrice a bordo / Condensing unit Included</b>						
Air / Aria	/	/	/	/	/	/
Water / Acqua	/	/	/	/	/	/
Air + Water / Aria + Acqua	/	/	/	/	/	/
<b>Unità condensatrice remota compresa (fino a 20 metri) / Remote condensing unit included (up to 20 meters)</b> <b>Unità condensatrice remota compresa semi-ermetica / Remote condensing unit included semi-hermetic</b>						
Air / Aria	/	/	/	/	/	/
Air + Water / Aria + Acqua	/	/	/	/	/	/
<b>Gelato. Allestimento vaschette / Container setup</b>						
<b>5 Lt</b> 360x165x120h	 12	18	18 (6+12)	24	24 (6+18)	13
<b>5 Lt</b> 360x250x80h	 8	12	14 (6+8)	16	18 (6+12)	9
<b>5 Lt</b> 360x250x80h trapezoidali	 -	-	-	-	-	14



# DIVA GELATERIA



ENERGY SAVING  
LED



INSTALLATION  
Plug-in



TEMPERATURE  
-20/+2°C



DEFROST  
Reverse Cycle



CLIMATIC CLASS  
7

DIVA  
ICE CREAM

DIVA  
GLACIER

DIVA  
EISCAFÉ

DIVA  
HELADERÍA









# DIVA PASTICCERIA



ENERGY SAVING  
LED



INSTALLATION  
Plug-in / Remote unit



TEMPERATURE  
+1/+10 °C



DEFROST  
Off cycle



CLIMATIC CLASS  
7

DIVA  
PASTRY

DIVA  
PÂTISSERIE

DIVA  
KONDITOREI

DIVA  
PASTELERÍA





ΔΙΔΑ





**ΔIVA**

# DIVA GELATERIA

		<b>120</b>	<b>170</b>	<b>220</b>
External dimensions (LxDxH)	H125	1166 x 1103 x 1257mm	1661 x 1103 x 1257 mm	2156 x 1103 x 1257 mm
Dimensioni esterne (LxPxH)	H140	1166 x 1103 x 1408 mm	1661 x 1103 x 1408 mm	2156 x 1103 x 1408 mm
Capacity (gross/net)	H125	719 / 147 lt	1059 / 216 lt	1399 / 285 lt
Capacità (lorda/netta)	H140	865 / 147 lt	1273 / 216 lt	1680 / 285 lt
Net weight	H125	300 kg	375 kg	470 kg
Peso netto	H140	325 kg	395 kg	480 kg
Refrigeration Refrigerazione	Ventilated - Doppia Ventilazione			
Refrigerant Refrigerante	R404A			
Climatic class Classe climatica	7			
Operating conditions Condizioni ambientali	35 °C / 75 %RH			
Cabinet capacity range Temperatura di regolazione	-20/+2 °C			
Product temperature Temperatura prodotto	-16/-14 °C			
Compressor (type) Compressore (tipologia)	1 Hermetic - 1 Ermetico	2 Hermetic - 2 Ermetico	2 Hermetic - 2 Ermetico	
Defrost Sbrinamento	Reverse Cycle / Inversione di Ciclo			
Power supply Alimentazione	230 V / 1 Ph / 50 Hz	400 V / 3 Ph / 50 Hz	400 V / 3 Ph / 50 Hz	
Electrical input (standard) Assorbimento elettrico	1240 W / 6 A	1720 W / 3 A	2700 W / 4,2 A	
Electrical input (defrost) Assorbimento elettrico	2300 W / 11 A	2950 W / 4,9 A	6300 W / 8,5 A	

<b>AE 45</b>	<b>120+50 COMBI</b>	<b>170+50 COMBI</b>
1835 x 1103 x 1257 mm	1661 x 1103 x 1257 mm	2156 x 1103 x 1257 mm
1835 x 1103 x 1408 mm	1661 x 1103 x 1408 mm	2156 x 1103 x 1408 mm
946 / 193 lt	1059 / 216 lt	1399 / 285 lt
1136 / 193 lt	1273 / 216 lt	1680 / 285 lt
378 kg	385 kg	480 kg
400 kg	408 kg	505 kg
Ventilated - Doppia Ventilazione		
R404A		
7		
35 °C / 75 %RH		
-20/+2 °C		
-16/-14 °C		
2 Hermetic - 2 Ermetico	2 Hermetic - 2 Ermetico	2 Hermetic - 2 Ermetico
Reverse Cycle / Inversione di Ciclo		
400 V / 3 Ph / 50 Hz		
1720 W / 3 A	1720 W / 3 A	2700 W / 4,2 A
2950 W / 4,9 A	2950 W / 4,9 A	6300 W / 8,5 A

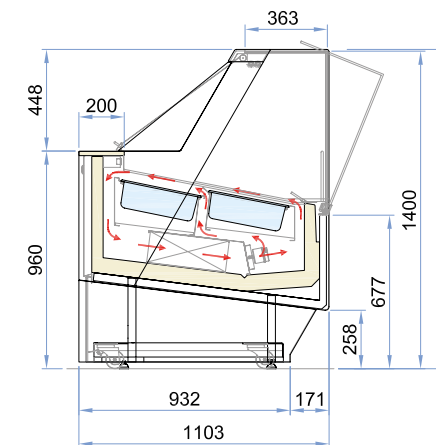
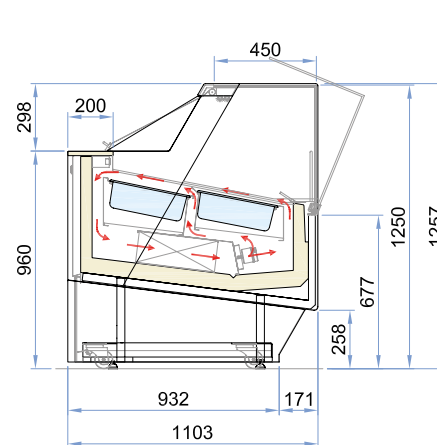

ΔIVA

## DIVA PASTICCERIA

		120	170	220	AE 45
External dimensions (LxDxH)	H125	1166 x 1103 x 1257 mm	1661 x 1103 x 1257 mm	2156 x 1103 x 1257 mm	1835 x 1213 x 1257 mm
Dimensioni esterne (LxPxH)	H140	1166 x 1103 x 1408 mm	1661 x 1103 x 1408 mm	2156 x 1103 x 1408 mm	1835 x 1213 x 1408 mm
Capacity (gross/net)	H125	720 / 214 lt	1059 / 317 lt	1398 / 418 lt	946 / 205 lt
Capacità (lorda/netta)	H140	865 / 239 lt	1272 / 254 lt	1680 / 466 lt	1136 / 200 lt
Net weight	H125	295 kg	375 kg	470 kg	368 kg
Peso netto	H140	318 kg	400 kg	492 kg	390 kg
Refrigeration Refrigerazione	Ventilated - Ventilata				
Refrigerant Refrigerante	R404A				
Climatic class Classe climatica	3				
Operating conditions Condizioni ambientali	25 °C / 60 %RH				
Product temperature Temperatura prodotto	+1 /+10 °C				
Compressor (type) Compressore (tipologia)	1 Hermetic - 1 Ermetico				
Defrost Sbrinamento	Off cycle - Fermata compressore				
Power supply Alimentazione	230 V / 1 Ph / 50 Hz				
Electrical input (standard) Assorbimento elettrico		1360 W / 7,4 A	1485 W / 8,1 A	1610 W / 8,7 A	1360 W / 7,4 A
Electrical input (defrost) Assorbimento elettrico		420 W / 2,3 A	485 W / 2,6 A	450 W / 2,4 A	420 W / 2,3 A

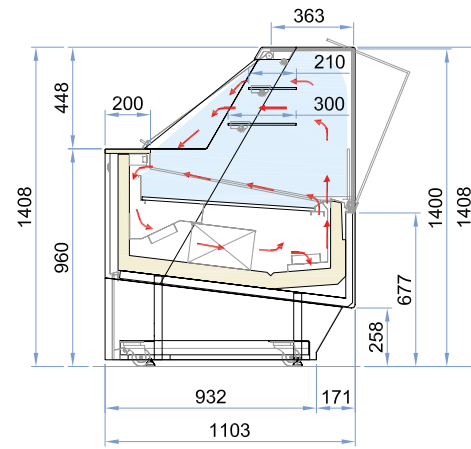
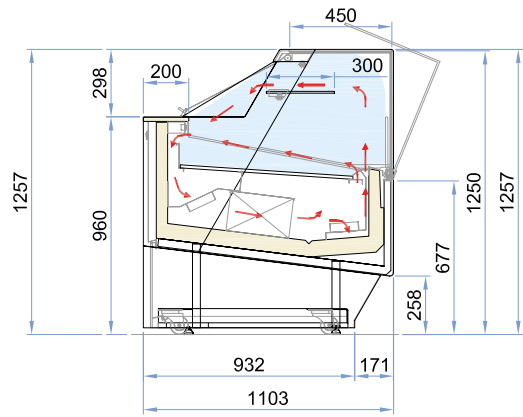



**ISA** nasce in Umbria, nel cuore di quell'Italia rinomata in tutto il mondo per la sua eccellenza artigiana, industriale e creativa. Con quattro stabilimenti e la presenza in oltre trenta mercati globali ISA è uno dei player al mondo più importanti del mercato dell'arredamento per locali pubblici, delle vetrine e degli armadi refrigerati per gelateria e pasticceria e dell'arredamento professionale.

EN

ISA was established in Umbria, in the heart of Italy, a nation that is famed all over the world for its artisan, industrial and creative excellence. With four sites and the presence in over thirty global markets, ISA is one of the most important players on furniture market for public places, ice cream display cabinets, pastry display cases and professional furniture.

FR

ISA nait en Ombrie, au milieu de cette partie-là d'Italie célèbre dans tout le monde pour son excellence artisanale, industrielle et créative. Avec quatre usines et en étant sur plus de trente marchés globaux, ISA est un des joueurs les plus importants sur le marché international de l'ameublement pour locaux publics, de vitrines et d'armoires d'exposition réfrigérées pour glacerie et pâtisserie et de l'ameublement professionnel.

DE

ISA wurde in Umbrien gegründet, im Herzen Italiens, die in der ganzen Welt für ihre handgefertigte, industrielle und kreative Vorzüglichkeit berühmt ist. Mit vier Werkanlagen und dank der Anwesenheit in mehr als dreißig ISA Global Märkten, ist ISA einer der wichtigsten Player der weltweiten Möbelmarkt für Lokale, Vitrinen und Kühlschränke für Eisdiele und Konditorei und professionelle Einrichtung.

ES

ISA nace en Umbria, en el corazón de una Italia de renombre en todo el mundo por su artesanía, industria y creatividad excelentes. Con cuatro establecimientos y presente en más de treinta mercados globales, ISA es uno de los principales protagonistas mundiales del mercado del mobiliario profesional y de locales públicos así como de los expositores y refrigeradores para heladería y pastelería.

La ISA S.p.A. nell'ambito del continuo miglioramento del prodotto, si riserva il diritto di modificare in qualsiasi momento, senza preavviso, le caratteristiche tecniche ed estetiche dei propri modelli.

In the interest of continual product improvements, ISA S.p.A. reserves the right to make changes in technical specifications and accessories at any moment and without prior notice.





428100160100

M1216R2



**ISA** S.p.A.

via del Lavoro 5  
06083 Bastia Umbra PG  
Italy

T. +39 075 801 71  
F. +39 075 800 09 00  
E. [customerservice@isaitaly.com](mailto:customerservice@isaitaly.com)

[www.isaitaly.com](http://www.isaitaly.com)