

# BAKERY, CATERING, PASTRY, PIZZA EQUIPMENT

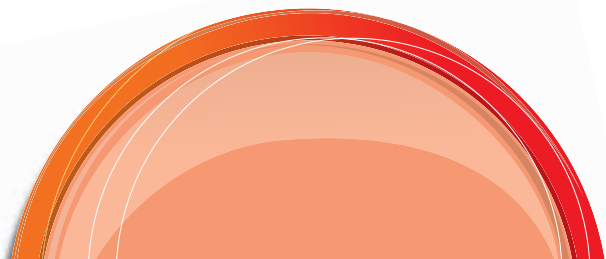

Catalogo  
Catalogue

40<sup>th</sup> SIGMA  
1974-2014





## STORIA

### 1973 Le origini.

SIGMA nasce verso la fine del 1973 anno in cui Luciano Gnocchi, dopo essere stato per diversi anni Responsabile dell'Ufficio Sviluppo e Progetti di una importante industria del Settore, ne fuoriesce e fonda la propria azienda iniziando a costruire impastatrici a spirale, vera novità per quell'epoca.

### 1974 La prima manifestazione fieristica.

Nei primi mesi del 1974 SIGMA parteciperà alla Sua prima Fiera di Settore a Genova dove esporrà i primi modelli di macchine impastatrici costruiti.

### 1974-1985 Lo sviluppo.

Durante questi anni SIGMA amplia il proprio portafoglio prodotti presentandosi in diversi mercati a livello mondiale. Dal Sud Africa al Nord Europa, da Singapore al Canada e al Brasile l'azienda potrà contare su numerosi rivenditori qualificati.

### 1985-2003 L'esperienza Multinazionale.

Interessata da un progetto industriale strategico, SIGMA riceve l'offerta per entrare a far parte di un gruppo leader mondiale del settore (VMI France), con il quale rimarrà fino al 2003, quando tornerà ad essere totalmente di proprietà della famiglia Gnocchi.

Durante tutti questi anni l'azienda ha l'opportunità di condividere e sviluppare il Know-how del gruppo sulle mescolatrici planetarie.

Ciò le permetterà di diventare il più grosso produttore in Italia di tali macchine con una produzione di oltre 1500 pz l'anno.

### 2004 ad oggi.

Il ritorno ad essere una azienda totalmente completamente italiana, dà un impulso importante al rilancio ed alla espansione di SIGMA.

Con l'obiettivo di allineare la struttura ai nuovi scenari di mercato, vengono introdotte nuove figure giovani ed innovative con capacità manageriali ed organizzative che assumono ruoli di responsabilità.

Dopo oltre 40 anni dall'inizio della sua sfida, SIGMA con lo stesso impegno e la passione che la hanno caratterizzata in tutti questi anni, è composta da un gruppo di persone attente all'ascolto ed al confronto con la clientela, stimolate costantemente dal miglioramento e dalla spinta all'innovazione, fattori che da sempre la contraddistinguono.



## STORY

### 1973 Origins.

SIGMA was born at around the end of 1973, when Mr Luciano Gnocchi, after being for several years responsible of the development and projects office of an important industry of the sector, leaves it and establishes his own company starting to manufacture spiral mixers, that was a real novelty at that time.

### 1974 The first exhibition.

In the first months of 1974 SIGMA takes part in its Sector Exhibition in Genova where it exhibits its first models of mixers.

### 1974-1985 Development.

During these years SIGMA makes its products range wider facing foreign markets: from South Africa to North Europe, from Singapore to Canada and Brasil. The company can rely on several qualified dealers.

### 1985-2003 Multinational Experience.

Interested in an industrial strategic project, SIGMA gets the offer to join a world leading bakery group (VMI France), with which it remains until 2003, when returns to be completely property of the Gnocchi family.

During all these years the company has the opportunity to share and develop the Know-how of the group on the planetary mixers.

All this allows SIGMA to become the biggest manufacturer

of such machines in Italy producing more than 1500 pieces per year.

### From 2004 till today.

The return to be a completely Italian company own by Gnocchi Family, gives an important boost to relaunching and expansion of SIGMA.

With the goal to align the structure to the new market scenes, new young and innovative figures, with managerial and organizing skills, start working in SIGMA assuming responsibility roles.

After more than 40 years from the beginning of his challenge, SIGMA with the same engagement and passion of the beginning, is today composed by a group of people listening carefully to their customers. They are stimulated constantly to a continuous improvement and by the push towards innovation, that has always distinguished SIGMA's philosophy.





## COSTANTE INNOVAZIONE E RICERCA

SIGMA pone da sempre al centro della propria strategia la continua innovazione e ricerca ed il costante miglioramento dei propri prodotti. L'Azienda, che può contare su un'ampia gamma di prodotti offerti, è sempre impegnata nell'arricchire ulteriormente il proprio portafoglio prodotti. Elementi portanti di tale scelta strategica sono: da un lato la Divisione Sviluppo Prodotti, costituita da un team di tecnici che segue la progettazione e l'intero ciclo di vita di ogni modello di macchina prodotta, coniugando qualità, sicurezza, affidabilità e la ricerca di ottime performances; dall'altro il Reparto Produzione che si occupa della fabbricazione in serie dei prodotti in portafoglio assicurandone la massima qualità ed affidabilità.

## LA DIVISIONE SVILUPPO PRODOTTI

Creata nel 2003 la Divisione ha l'obiettivo di ricercare costantemente soluzioni innovative volte al raggiungimento dell'eccellenza e della massima affidabilità dei prodotti sviluppati. Dotato dei più moderni sistemi di progettazione, il team che la costituisce è fatto da persone altamente competenti e specializzate in grado di seguire l'intero ciclo di vita dei prodotti, sviluppando un know how interno e lavorando in stretta collaborazione con tutte le altre componenti aziendali.

## IL REPARTO PRODUZIONE

I prodotti creati da SIGMA si caratterizzano da sempre per qualità, affidabilità, sicurezza e prestazioni che li distinguono nel mercato. Tale risultato è reso possibile anche grazie all'organizzazione produttiva che risponde ai criteri più avanzati della produzione meccanica industriale, anche me-

dante l'informatizzazione di alcuni processi di lavorazione, riuscendo così a coniugare l'efficienza produttiva con una attenta ricerca di qualità nei dettagli, garantita dalla lavorazione artigianale eseguita da esperti meccanici durante tutte le differenti fasi della produzione. A questa area aziendale fanno capo l'industrializzazione di prodotto e di processo, mentre i diversi centri di esecuzione sono specializzati per tipologia e classe dimensionale dei prodotti. Dotati di attrezzature di altissima qualità e delle più moderne procedure produttive, i centri di esecuzione e produzione sono ubicati nello stabilimento di Torbole Casaglia (BS). La grande affidabilità e solidità dei prodotti fabbricati, l'investimento nelle certificazioni dei propri macchinari e l'adeguamento ai più alti standard igienici e di sicurezza, hanno costituito i fattori di successo che contraddistinguono l'azienda nel mercato. Ad oggi nel mondo sono operanti diverse migliaia di macchine con grande soddisfazione dei loro utilizzatori.

## LA DIVISIONE COMMERCIALE

Si avvale prevalentemente di figure direttamente collegate all'Azienda integrate da una rete di Agenti e Sub Agenti. La forte competenza di settore maturata attraverso una lunga esperienza sul campo ne costituisce il tratto dominante oltre alla spiccata sensibilità ad ascoltare le esigenze ed i suggerimenti che provengono dai propri clienti/ distributori. Una qualificata struttura di back office, formata da un team di persone ben rodute all'interno dell'azienda, asseconda in tempi rapidi tutte le esigenze informative dei clienti relativamente a quotazioni, tempi di consegna, trasporti e assistenza sui ricambi.



## CONSTANT INNOVATION AND RESEARCH

SIGMA has always put at the centre of its own strategy the continuous innovation and research and the constant improvement of their products. The company, which can rely on a wide range of products, is always engaged to enrich more and more its range of products. Important elements of such strategic choice are: on one side the Products Development Division, made of a team of highly specialised technicians who follow the development and the whole life cycle of each model of machine manufactured by SIGMA, combining quality, security, reliability and the research of excellent performances; on the other side the Production Department, which is responsible for the mass-production of the range assuring the maximal quality and reliability.

## THE DEVELOPMENT PRODUCTS DIVISION

The Division was created in 2003 with the goal to research constantly innovative solutions for reaching the excellence and the maximum reliability of the developed products. Equipped with the most modern projecting systems, the team is made by highly competent and specialised people able to follow the whole life cycle of the products, developing an inner know how, working in tight collaboration with all the other company components.

## THE PRODUCTION DEPARTMENT

The products manufactured by SIGMA stand up for their quality, reliability, security and performances in the market. Such a result is possible also thanks to the productive organization that respects the most advanced criteria of the indu-

strial mechanical production and also to the computerization of some work processes, managing to combine the productive efficiency with a careful research of quality in the details. This is guaranteed by the handcraft work made by expert mechanics during the different production phases. The product and process industrialisation refers to this department, while the various execution centres are specialised according to the typology and dimensional class of the products. Equipped with very high quality and with the most modern productive procedures, the execution and production centres are located in the factory in Torbole Casaglia (BS). The great reliability and sturdiness of the products manufactured, the investment in the certifications of its machines, the bringing in line with the highest hygienic and safety standards have brought SIGMA to the success, for which it stands up in the market. Nowadays in the world several thousands of machines are working with big satisfaction of their users.

## THE COMMERCIAL DEPARTMENT

Made of several people, the Commercial Division avails itself of figures directly related with the Company and is supplemented by a net of Agents and Subagents. The strong competence of the sector, reached through a long field experience, is its dominant feature besides their remarkable sensitivity to listen to the needs and suggestions coming from customers and dealers. A qualified back office structure, made of a team of skilled people ripened inside the company, satisfies quickly all kinds of requests of customers concerning quotations, delivery time, transport and spare parts assistance.



## PRODOTTI

SIGMA ha sempre costruito macchine per la panificazione sviluppando un continuo Know how tale da renderla una delle aziende più specializzate nei processi di impasto per il mercato della panificazione.

L'ampia gamma di prodotti offerti è progettata internamente da Tecnici altamente specializzati della Divisione Sviluppo Prodotti, ed è prodotta interamente nel moderno stabilimento in Italia dove è ubicata anche la propria sede.

SIGMA è presente anche in Russia con un Team di rappresentanza e promozione a Mosca per l'Area delle ex Repubbliche Sovietiche ed uno in Serbia per tutti i paesi dell'area del Sud Est Europa.

Può contare inoltre su una ampia rete di oltre 400 rivenditori a livello mondiale, che commercializzano i suoi prodotti in oltre 80 Paesi, garantendo alla propria clientela un elevato livello di assistenza.



## PRODUCTS

SIGMA has always being manufacturing machines for bakery, developping a continuous "Know how", so that it became one of the most specialised companies in the dough processes for the bakery market.

Such a specialisation is shared by all the employees of the company who are incited more and more in the continuous research towards quality and attention to the details.

A common engagement which allowed the company to reach important results. The wide range of offered products is projected wholly by highly specialised technicians of the Products Development Department and is manufactured completely in the modern factory in Italy where also its seat is located.

SIGMA is present also in Russia with an agency and promotional Team in Moscow responsible for the area of the ex Soviet Republics and one in Serbia responsible for all the countries of the South East Europe.

SIGMA relies on a wide range of more than 400 dealers worldwide who trade its products in more than 80 countries, guaranteeing its customers a high assistance level.



# Command & Diagnostic App

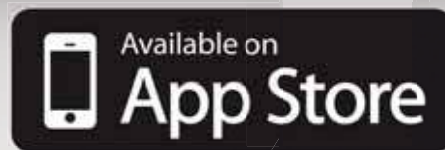
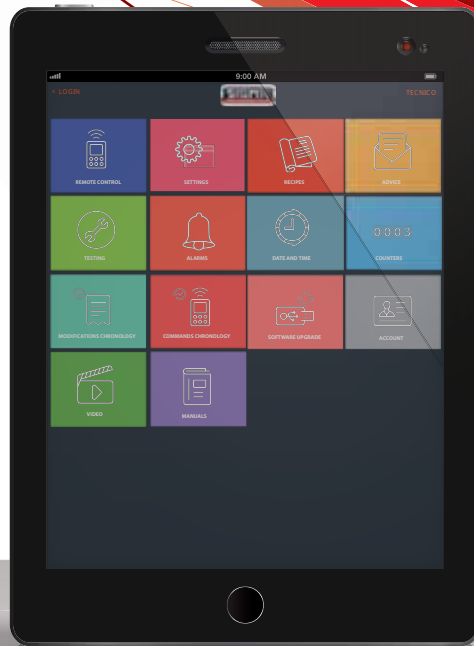

Internet  
of Things



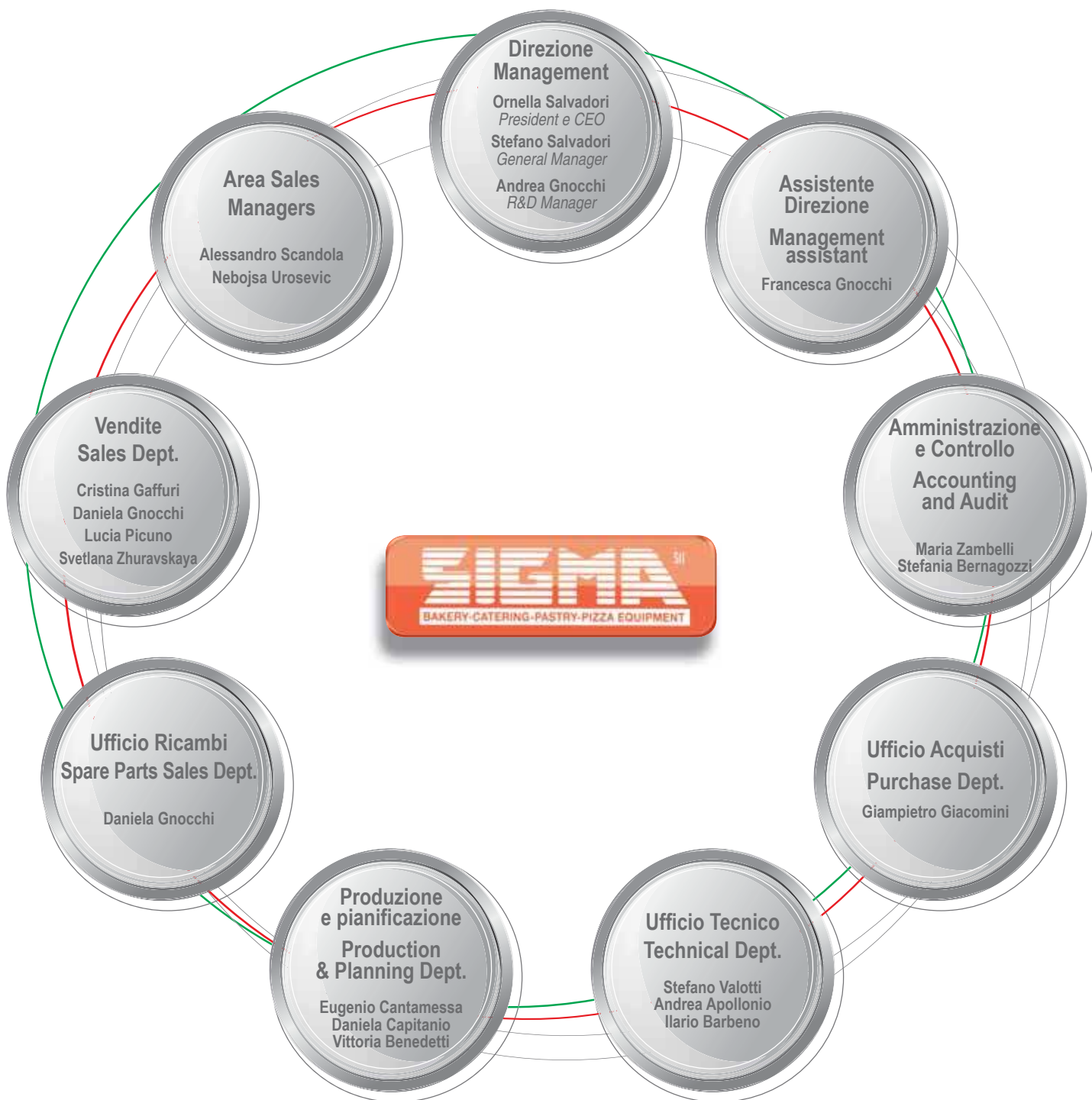

## Condizioni di vendita General Terms Of Sales



### Prodotti

Il presente LISTINO PREZZI annulla e sostituisce, con decorrenza dal 1 Gennaio 2015, tutti i precedenti.

### Ordini

Tutti gli ordinativi si intenderanno accettati solo tramite nostra conferma d'ordine della quale una copia dovrà esserci resa sottoscritta per accettazione.

### Pagamenti

Le condizioni di pagamento sono da concordarsi di volta in volta. Eventuali spese per bollo effetti e/o tratte, registrazione contratti ecc., sono sempre a carico dell'acquirente.

### Resa

La merce si intende sempre resa franco fabbrica; nel caso di trasporto effettuato con nostri mezzi, il relativo costo sarà addebitato in fattura.

### Trasporto

A carico del cliente. Eventuali contestazioni sullo stato difettoso del materiale, devono essere evidenziate al trasportatore al momento dell'accettazione della merce.

### Imballo

Eventuale imballaggio sarà addebitato in fattura.

### Garanzia

Tutte le parti componenti le macchine, escluso le parti elettriche, godono di una garanzia di 12 mesi, quando i difetti sono dovuti alla costruzione. La garanzia non contempla la sostituzione della macchina. La garanzia non contempla le spese di manodopera per la sostituzione dei ricambi e qualsiasi altra spesa accessoria.

### I.V.A.

Esclusa.

### Conformità

Tutte le macchine vengono consegnate con Certificato di Conformità e Targa CE.

### Fotografie

Le fotografie ed i colori delle macchine rappresentate nel listino e sui cataloghi sono puramente indicative.

**SIGMA srl si riserva la facoltà di effettuare cambiamenti e/o migliorie senza alcun preavviso.**



### Products

This PRICE LISTE cancels and replaces, starting from January 1<sup>st</sup> 2015, all the previous ones.

### Orders

All the orders will be considered accepted only after our order confirmation. One copy of it has to be returned duly signed.

### Payments

The payment terms will be agreed each time.

### Delivery Terms

Delivery terms are usually ex-works.

### Transport

To be paid by the customer. Possible complaints for damaged goods must be pointed out to the forwarder at the moment of the acceptance of the goods.

### Packing

To be added in the invoice.

### Warranty

All the components of our machines, except for the electrical parts, have a one-year guarantee, starting from the delivery date, when there are manufacturing defects. The warranty doesn't imply the replacement of the machine. It also doesn't imply the costs of labor for the replacement of spare parts and all the other possible expenses.

### Taxes

Duties and local taxes are at customer's charge.

### Conformity

All our machines have the CE Certification.

### Photos

Pictures and colours of the machines shown in both price list and catalogues are illustrative.

**Sigma srl reserves the right to change them without informing.**



[www.sigmasrl.com](http://www.sigmasrl.com)



**Catalogo  
Catalogue**



**Pasticceria**  
Pastry & Confectionary



**14**



**Pizza**



**32**



**Panificazione**  
Bakery



**48**

BAKERY

CATERING

PASTRY

PIZZA

EQUIPMENT



**Chef**  
Planetarie a variazione elettronica  
Planetary mixers with electronic  
speed variator



**Best mix**  
Planetarie a variazione meccanica  
Planetary mixers with mechanical  
speed variator



**RF300**  
Raffinatrice a 2 cilindri  
2 cylinders Grinding machine



**Tauro**  
Impastatrici a spirale a vasca  
fissa da banco  
Bench Spiral Mixers with fixed bowl



**Divider-rounders**  
Spezzarrotondatrici da banco  
Bench Divider-rounders



**Sfera**  
Arrotondatrice a coclea  
Screw Rounder



**Aeromix**  
Impastatrici planetarie  
Planetary Mixers



**Powermix**  
Impastatrici planetarie automatiche  
a disimpegno totale  
Automatic Planetary Mixers  
with total disengagement



**Red Line**  
Impastatrici a spirale a vasca fissa  
Spiral Mixers with fixed bowl



**Gold Line**  
Impastatrici a spirale con scarico dal fondo  
Spiral mixers with bottom discharge



**A bracci tuffanti**  
Impastatrici a bracci tuffanti  
Twin arms mixers



**A forcella**  
Impastatrici a Forcella  
Fork mixers



**Tramogge**  
Tramogge di alimentazione  
Feeding Hoppers



**Spezzatrici  
Volumetriche**  
Spezzatrici volumetriche  
Volumetric Dividers



**Arrotondatrici  
Coniche**  
Arrotondatrici coniche  
Conical Rounders



**Cuocicrema**

Cuocicrema a gas  
Cream cookers with gas burner



**Electric Cookers**

Cuocitori elettrici  
Electric cookers



**Sfogliatrici**

Sheeters



**Sprizza**

Stenditrici a freddo per pizza  
Cold system Pizza spinner



**Sfogliatrice verticale**

Vertical sheeter



**Green Line**

Impastatrici a spirale a vasca fissa  
Spiral Mixers with fixed bowl



**Autosvuotanti**

Impastatrici a spirale autosvuotanti  
Overtunable Spiral Mixers



**Silver Line**

Impastatrici a spirale con vasca estraibile  
Spiral mixers with removable bowl



**Super Premium**

Impastatrici a spirale con vasca estraibile  
Spiral mixers with removable bowl



**Maciste  
MacisteMax**

Sollevatori per vasche estraibili  
Spiral mixer Lifters



**Hercules**

Sollevatori per vasche estraibili  
Spiral mixer Lifters



**Sollevatori  
Planetarie**

Sollevatori per vasche planetarie  
Planetary mixer Lifters



**Ribaltatori**

Tipper lifters



**Spezzarrotondatrici**

Bun Dividers



**Esagonali/Quadre**

Spezzatrici esagonali e quadre  
Hexagonal and Square Dividers



**Formatrici  
a 3 cilindri**

Formatrici per Baguette a 3 cilindri  
3 cylinders Baguette moulders



**Formatrici  
a 2 cilindri**

Formatrici per pane avvolto  
Long loaf moulders

# Pasticceria - Pastry & Confectionary



**16 Chef**  
Planetarie a variazione elettronica  
Planetary mixers with electronic speed variator



**18 Best mix**  
Planetarie a variazione meccanica  
Planetary mixers with mechanical speed variator



**20 Accessori**  
Accessori per planetarie  
Planetary Mixers Assessories



**24 RF300**  
Raffinatrice a 2 cilindri  
2 cylinders Grinding machine



**26 Cuocicrema**  
Cuocicrema a gas  
Cream cookers with gas burner



**28 Electric Cookers**  
Cuocitori elettrici  
Electric cookers



**30 Sfogliatrici**  
Sheeters







## Pasticceria Pastry & Confectionary



### “Chef”

Impastatrici planetarie a variazione elettronica  
Planetary mixers with electronic speed variator



Modello Model	KW	Peso Weight (Kg)	Alimentazione Voltage	Vasca Bowl (Lt.)	Diametro Vasca Bowl dimension (mm)	Dimensioni Dimension (mm)
CHEF 7,5	0,25	33	220/1/50	7,5	230X210	365X400X615
CHEF 10	0,55	55	220/1/50	10	250x230	560x600x775
CHEF 20	0,75	80	220/1/50	20	315x290	605x725x840
CHEF 20H	0,75	95	220/1/50	20	315x290	605x725x1180
CHEF 30	1,1	100	220/1/50	30	350x365	605x735x1180
CHEF 40	1,5	190	220/1/50	40	400x370	700x920x1355
CHEF 60	2,2	225	220/1/50	60	450x370	730x985x1490

#### CARATTERISTICHE TECNICHE GENERALI GENERAL TECHNICAL CHARACTERISTICS

- Variatore elettronico (Inverter)
- 6 velocità
- Elevata coppia a bassi regimi
- Dotazione standard: spirale, pala, frusta
- Planetarie da terra con piedini inox
- Struttura acciaio di grosso spessore
- Motore trifase con alimentazione monofase
- Griglia inox asportabile
- Normative CE
- Certificazione GOST
- Electronic variator (Inverter)
- 6 speeds
- High torque at low speed
- Standard equipment: spiral, blade and whisk
- Structure in high thickness steel sheet
- Stainless steel feet on floor standing planetary mixers
- Three-phase motor with single-phase input
- Removable stainless steel grid
- CE rules
- GOST certification

#### OPTIONALS

- Tensioni speciali
- Riduzioni per vasche e accessori
- Versione in Inox
- Kit utensili in acciaio inox
- Sistema riscaldamento vasca
- Tappo vasca
- Special tensions
- Smaller bowls and tools available
- Stainless steel version
- Stainless steel tools Kit
- Heating Bowl System
- Drain Bowl cap



Le planetarie della serie Chef sono macchine particolarmente adatte all'uso nel settore alberghiero. Simili alla serie Best Mix per ciò che riguarda potenze, utensili e vasche, esse sono più compatte e quindi meno ingombranti. L'azionamento avviene mediante variatore elettronico a 6 velocità preimpostate, premendo pulsanti di grande semplicità operativa. La grande riserva di potenza e la eccezionale robustezza le rendono adatte ad un uso altamente professionale. La griglia di protezione facilmente smontabile per il lavaggio, i dispositivi di sicurezza, le molte parti trattate al nichel chimico alimentare e le verniciature certificate hanno consentito a questa linea di macchine di ottenere l'approvazione dei più prestigiosi enti internazionali certificatori della qualità. Oltre alle dotazioni standard come vasca, pala, frusta e spirale, le macchine possono essere dotate di una numerosa serie di accessori come raschiatori, fruste speciali, protezioni trasparenti, riduttore con presa di forza laterale, macinacarne, tagliaverdure, vasche e utensili ridotti, bruciatori a gas. Il tutto consente di offrire al cliente un'ampia scelta per ottenere dalla macchina il massimo della efficienza e versatilità.



Die Planetenrührmaschinen der ChefBaureihe sind Maschinen, die insbesondere für den Hotelbereich geeignet sind. Leistung, Zubehör und Wannen sind ähnlich wie bei der Best Mix-Baureihe, nur kompakter und platzsparender. Der Antrieb erfolgt über einen elektronischen Regler (Inverter), welcher es erlaubt mit 6 voreingestellten Geschwindigkeiten zu arbeiten, indem die entsprechenden leicht zu bedienenden Tasten gedrückt werden. Durch die große Kraftreserve und die hervorragende Robustheit ist die Maschine für professionelle Anwendungen auf hohem Niveau bestens geeignet. Das zur Reinigung leicht abzumontierende Schutzgitter, die Sicherheits-vorrichtungen, die vielen für die Lebensmittelproduktion chemisch mit Nickel behandelten Teile sowie die zertifizierten Lackierungen haben dazu geführt, dass diese Maschinenbaureihe die Abnahmeprüfungen der namhaftesten internationalen Qualitätsprüfeinrichtungen bestanden hat. Außer der Standardausrüstung wie Wanne, Mischflügel, Schneebeesen und Spirale, können die Maschinen auch mit vielen Zubehörteilen wie Schaber, besonderen Schneebeesen, transparenten Schutzvorrichtungen, Untersetzungsgetriebe mit seitlicher Befestigung, Hackfleischmühle, Gemüseschneider, kleineren Wannen und Mischwerkzeugen und Gasbrennern ausgestattet werden. All dies erlaubt es, dem Kunden eine weitreichende Auswahl anzubieten, welche höchste Effizienz und Versatilität garantiert.



The Chef line planetary mixers are highly recommended for use in the hotel sector. Though similar to the Best Mix line in terms of power, tools and bowls, these machines are more compact and therefore take up less space. The electronic inverter control, with its easy-to-use buttons, operates the 6 preset speed modes. Thanks to their long-lasting power supply and durable construction, these machines stand up to rigorous professional use. The protection grid, which is easily detachable for cleaning, the safety devices, the fact that most parts of the machines are treated with nickel plating for food use and the certified paint finishes have earned this series the approval of the most prestigious international quality certifiers. In addition to the standard features like the bowl, the blade, the whip and the spiral, these machines can also be equipped with a number of extra accessories like scrapers, special whips, trolleys for bowl, transparent safety protection, reducers, meat mincers, vegetable slicers, reduction bowls and tools and gas burners. All these features offer our customers a wide range of choices, allowing them to obtain the maximum efficiency and versatility from our machines.



Las planetarias de la serie Chef son máquinas particularmente aptas para ser utilizadas en el sector hotelero. Similares a las de la serie Best Mix en cuanto a potencia, utensilios y perrol, éstas son más compactas y por lo tanto menos voluminosas. El accionamiento mediante variador electrónico (inverter) permite gestionar las 6 velocidades predisuestas presionando los pulsadores de gran simplicidad operativa. La gran reserva de potencia y la excepcional robustez las hacen idóneas para un uso altamente profesional. La rejilla de protección fácilmente desarmable para el lavado, los dispositivos de seguridad, las numerosas piezas tratadas con níquel químico alimentario y los barnizados certificados han permitido que esta línea de máquinas obtuviera la aprobación de los más prestigiosos entes internacionales de certificación de calidad. Además de las dotaciones estándar tales como el perrol, la pala, el batidor y la espiral, las máquinas pueden ser dotadas de una nutrida serie de accesorios como rascadores, batidores especiales, protecciones transparentes, reductor con toma de energía lateral, picador de carne, corta verduras, perrol y utensilios reducidos, quemadores de gas. Todo esto nos permite brindar al cliente una amplia gama de posibilidades para obtener de la máquina la máxima eficiencia y versatilidad.



Les batteurs de la série Chef sont des machines particulièrement adaptées à l'utilisation dans le secteur de l'hôtellerie. Similaires à la série Best Mix en ce qui concerne les puissances, les outils les cuves, elles sont plus compactes et donc moins encombrantes. L'actionnement par le variateur électronique (inverter) permet de gérer les 6 vitesses préétablies en appuyant sur les boutons de grande simplicité opérative. La grande réserve de puissance et l'exceptionnelle robustesse les rendent aptes à une utilisation hautement professionnelle. La grille de protection facilement démontable pour le nettoyage, les dispositifs de sécurité, les nombreuses parties traitées au nickel chimique alimentaire et les vernis certifiés ont permis à cette ligne de machines d'obtenir l'approbation des plus prestigieux organismes internationaux qui certifient la qualité. En plus des équipements standards comme la cuve, la palette, le fouet et la spirale, les machines peuvent être équipées d'une série d'accessoires comme les racleurs, les fouets spéciaux, les chariots porte cuve, les protections transparentes, les réducteurs avec prise de force latérales, les hacheviande, les coupe-légumes, les cuves et les ustensiles réduits, les brûleurs à gaz. Le tout permet d'offrir au client un grand choix afin d'obtenir de la machine le maximum de l'efficacité et de l'assortiment.



Планетарные тестомесильные машины серии Chef – это машины, особенно рекомендованные для использования в гостиничной сфере. Они похожи на серию Best Mix по мощности, принадлежности и дежам, но они более компактны и занимают меньше места. Эти машины с 6-ю предварительно установленными скоростями легко запустить с помощью кнопок включения электронного инвертора. Большой запас мощности и прочная конструкция делают эти машины пригодными для высоко профессионального использования. Защитная решетка, легко снимаемая для мытья, устройства безопасности и никелированные детали для пищевого применения, а также покраска сертифицированной краской, позволили данной линии машин получить сертификаты наиболее престижных международных сертификационных органов по качеству. Кроме стандартных принадлежностей, таких как дежа, лопатка, венчик и спираль, эти машины могут быть оснащены большим количеством дополнительных принадлежностей, таких как скребки, специальные венчики, тележки для деж, прозрачные защитные крышки, редукторы, мясорубки, овощерезки, дежи меньшего размера, инструменты и газовые горелки. Всё это позволяет предложить заказчикам широкий выбор для достижения максимальной эффективности и многоцелевого применения машин.





## Pasticceria Pastry & Confectionary



### “Best Mix”

Impastatrici planetarie a variazione meccanica  
Planetary mixers with mechanical speed variator



Modello Model	KW	Peso Weight (Kg)	Alimentazione Voltage	Vasca Bowl (Lt.)	Diametro Vasca Bowl dimension (mm)	Dimensioni Dimension (mm)
BM 10	0,5	55	400/3/50	10	250x230	365x400x615
BM 20	0,9	90	400/3/50	20	315x290	560x600x775
BM 20H	0,9	105	400/3/50	20	315x290	605x725x840
BM 30	1,1	110	400/3/50	30	350x365	605x725x1180
BM 40	1,5	205	400/3/50	40	250x230	605x735x1180
BM 60	2,2	240	400/3/50	60	315x290	700x920x1355
BM 80	3,0	280	400/3/50	80	315x290	730x1000x1490

#### CARATTERISTICHE TECNICHE GENERALI GENERAL TECHNICAL CHARACTERISTICS

- Variatore meccanico a cinghia a 7 velocità (10-20-30-40 Lt.) a 15 velocità (60-80 Lt.)
- Salita e discesa vasca elettronica sui modelli 40-60-80
- Elevata e costante coppia motrice in tutte le velocità
- Motore trifase con alimentazione trifase
- Planetarie da terra con piedini inox
- Dotazione standard: spirale, pala, frusta
- Funzionamento con timer o manuale
- Griglia inox asportabile
- Normative CE
- Certificazioni GOST
- Belt speed variator 7 speeds (10-20-30-40 Lt.) 15 speeds (60-80 Lt.)
- Motorized bowl lifting
- High and constant torque at all speeds
- Three-phase motor with three-phase input
- Stainless steel feet on floor standing planetary mixers
- Manual operation or with timer
- Standard equipment: spiral, blade, whisk
- Removable stainless steel grid
- CE rules
- GOST certifications

#### OPTIONALS

- Tensioni speciali
- Riduzioni per vasche e accessori
- Versione in Inox
- Kit utensili in acciaio inox
- Sistema riscaldamento vasca
- Tappo vasca
- Riduttore per attacco accessori
- Special tensions
- Smaller bowls and tools available
- Stainless steel version
- Stainless steel tools Kit
- Heating Bowl System
- Drain Bowl cap
- Reducer



Best Mix è il nome di queste planetarie dalle caratteristiche eccezionali. Impeccabili nei rapporti di velocità, esse danno i migliori risultati qualitativi nelle emulsioni, mescolazioni ed impasti per pasticceria e gastronomia. Migliaia di esemplari costruiti sono la migliore garanzia della affidabilità e robustezza di queste macchine. Il particolare variatore a cinghia fornisce una ampia escursione fra minimo e massimo e garantisce i più alti valori di coppia ai bassi regimi. La grande riserva di potenza e la eccezionale robustezza le rendono adatte ad un uso altamente professionale. La griglia di protezione facilmente smontabile per il lavaggio, i dispositivi di sicurezza, le molte parti trattate al nichel chimico alimentare e le verniciature certificate hanno consentito a questa linea di macchine di ottenere l'approvazione dei più prestigiosi enti internazionali certificatori della qualità. Oltre alle dotazioni standard come vasca, pala, frusta e spirale, le macchine possono essere dotate di una numerosa serie di accessori come raschiatori, fruste speciali, carrelli porta vasca, protezioni trasparenti, riduttore con presa di forza laterale, macinacarne, tagliaverdure, vasche e utensili ridotti, bruciatori a gas. Il tutto consente di offrire al cliente un'ampia scelta per ottenere dalla macchina il massimo della efficienza e versatilità.



Best Mix ist der Name dieser Planetenrührmaschine mit herausragenden Eigenschaften. Die einwandfreien Geschwindigkeitsverhältnisse erlauben die qualitativ höchsten Resultate bei Emulsionen, Mischungen und Teigmassen im Konditorei- und Gastronomiebereich. Tausende bereits hergestellte Exemplare sind die beste Garantie für die Zuverlässigkeit und Robustheit dieser Maschinen. Das besondere stufenlose Keilriemengetriebe erlaubt eine weite Spanne zwischen niedrigster und höchster Geschwindigkeit und garantiert die höchsten Drehmomentwerte bei niedrigen Drehzahlen. Durch die große Kraftreserve und die hervorragende Robustheit ist die Maschine für professionelle Anwendungen auf hohem Niveau bestens geeignet. Das zur Reinigung leicht abzumontierende Schutzgitter, die Sicherheitsvorrichtungen, die vielen für die Lebensmittelproduktion chemisch mit Nickel behandelten Teile sowie die zertifizierten Lackierungen haben dazu geführt, dass diese Maschinenbaureihe die Abnahmeprüfungen der namhaftesten internationalen Qualitätsprüfeinrichtungen bestanden hat. Außer der Standardausrüstung wie Wanne, Mischflügel, Schneebesens und Spirale, können die Maschinen auch mit vielen Zubehörteilen wie Schaber, besonderen Schneebesens, Wannentransportvorrichtungen, transparenten Schutzvorrichtungen, Untersetzungsgetriebe mit seitlicher Befestigung, Hackfleischmühle, Gemüseschneider, kleineren Wannen und Mischwerkzeugen, Gasbrennern ausgestattet werden. All dies erlaubt es, dem Kunden eine weitreichende Auswahl anzubieten, welche höchste Effizienz und Versatilität garantiert.



Best Mix is the name of this line of planetary mixers with exceptional features. With their outstanding speed ratio, they offer the best results in terms of quality when used for making emulsions, mixtures and dough for pastry-making and food preparations. The thousands of units we have produced testify to the reliable and long-lasting performance of these machines. Our unique belt variators offer a wide range of speeds between maximum and minimum guaranteeing the highest low speed torque values. Thanks to their long-lasting power supply and durable construction, these machines stand up to rigorous professional use. The protection grid, which is easily detachable for cleaning, the safety devices, the fact that most parts of the machines are treated with nickel plating for food use and the certified paint finishes have earned this series the approval of the most prestigious international quality certifiers. In addition to the standard features like the bowl, the blade, the whip and the spiral, these machines can also be equipped with a number of extra accessories like scrapers, special whips, trolleys for bowls, transparent safety protection, reducers, meat mincers, vegetable slicers, reduction bowls and tools and gas burners. All these features offer our customers a wide range of choices, allowing them to obtain the maximum efficiency and versatility from our machines.



Best Mix es el nombre de estas batidoras de características excepcionales. Impecables en las relaciones de velocidad, éstas brindan los mejores resultados de calidad en las emulsiones, mezclas y amasados para pastelería y gastronomía. Miles de ejemplares fabricados son la mejor garantía de la fiabilidad y robustez de estas máquinas. El variador de correa con características particulares suministra un amplio recorrido entre el mínimo y el máximo y garantiza los más elevados valores de par en bajos regímenes. La gran reserva de potencia y la excepcional robustez las hacen adecuadas para un uso altamente profesional. La rejilla de protección fácilmente desarmable para el lavado, los dispositivos de seguridad, las numerosas piezas tratadas con níquel químico alimentario y los barnizados certificados han permitido que esta línea de máquinas obtuviera la aprobación de los más prestigiosos entes internacionales de certificación de calidad. Además de las dotaciones estándar tales como el perrol, la pala, el batidor y la espiral, las máquinas pueden ser dotadas de una nutrida serie de accesorios como rascadores, batidores especiales, carritos porta cubetas, protecciones transparentes, reductor con toma de energía lateral, picador de carne, corta verduras, perrol y utensilios reducidos, quemadores de gas. Todo esto nos permite brindar al cliente una amplia gama de posibilidades para obtener de la máquina la máxima eficiencia y versatilidad.



Best Mix est le nom de ce batteur mélangeur avec caractéristiques exceptionnelles. Les rapports de vitesse sont impeccables et donnent les meilleurs résultats relatifs à la qualité des émulsions, des mélanges et des pétrissages pour les pâtisseries et les plats cuisinés. Les milliers d'exemplaires construits sont la meilleure garantie de la fiabilité et de la robustesse de ces machines. Le variateur particulier à courroie fournit une ample exécution entre le minimum et le maximum et garantit les valeurs les plus élevées de couple à bas régimes. La grande réserve de puissance et l'exceptionnelle robustesse les rendent aptes à une utilisation hautement professionnelle. La grille de protection facilement démontable pour le nettoyage, les dispositifs de sécurité, les nombreuses parties traitées au nickel chimique alimentaire et les vernis certifiés ont permis à cette ligne de machines d'obtenir l'approbation des plus prestigieux organismes internationaux qui certifient la qualité. En plus des équipements standards comme la cuve, la palette, le fouet et la spirale, les machines peuvent être équipées d'une série d'accessoires comme les racleurs, les fouets spéciaux, les chariots porte cuve, les protections transparentes, les réducteurs avec prise de force latérales, les hache-viande, les coupe-légumes, les cuves et les ustensiles réduits, les brûleurs à gaz. Le tout permet d'offrir au client un grand choix afin d'obtenir de la machine le maximum de l'efficacité et de l'assortiment.



Best Mix – это тип планетарных машин, обладающих удивительными характеристиками. Безукоризненные по соотношению скоростей, они дают наилучшие качественные результаты при производстве эмульсий, смесей и теста для кондитерских и кулинарных изделий. Тысячи созданных машин являются лучшей гарантией их надежности и прочности. Особый ременный вариатор предоставляет широкий диапазон между минимальной и максимальной скоростями, а также гарантирует самые высокие значения момента при низких режимах. Благодаря большому запасу мощности и чрезвычайной прочности, эти машины пригодны для высоко профессионального использования. Защитная решётка, легко снимаемая для мытья, защитные устройства, многочисленные детали, покрытые никелем, пригодным для использования с пищевыми продуктами, а также сертифицированная краска, позволили данной линии машин получить сертификаты, подтверждающие качество, от наиболее престижных международных сертификационных органов. Дополнительно к стандартным принадлежностям, таким как дежа, лопатка, венчик и спираль, эти машины могут быть также укомплектованы некоторыми дополнительными принадлежностями, такими как скребки, специальные венчики, тележки для деж, прозрачные защитные устройства, редуктор понижающей передачи, мясорубки, овощерезки, дежи меньшего объема, инструменты и газовые горелки. Всё это позволяет предложить заказчику широкий выбор для достижения максимальной эффективности и многоцелевого применения машины.



## Accessori per planetarie Planetary Mixers Accessories



Codice Code	Descrizione Description	
01175030-1	Frusta/Wired whisk CHEF 7,5 mm 2	
01098114	Frusta/Wired whisk BM-CHEF-AMX 10 mm 3	
01097114	Frusta/Wired whisk BM-CHEF-AMX 20 mm 3	
01161011	Frusta/Wired whisk BM-CHEF-AMX 30 mm 3	
01095058	Frusta/Wired whisk BM-CHEF-AMX 40 mm 3	
01101058	Frusta/Wired whisk BM-CHEF 60 mm 3	
01101159-2	Frusta/Wired whisk BM 80 mm 4	
<b>FRUSTE SPECIALI/SPECIAL WIRED WHISKS</b>		
01097128	Frusta/Wired whisk BM-CHEF-AMX 20 mm 4	
01161016	Frusta/Wired whisk BM-CHEF-AMX 30 mm 4	
01095059	Frusta/Wired whisk BM-CHEF-AMX 40 mm 5	
01101059	Frusta/Wired whisk BM-CHEF 60 mm 5	
87101190	Frusta speciale/Special whisk BM 80 mm 6	
01175091	Pala/Blade CHEF 7,5	
01098165	Pala/Blade BM-CHEF-AMX 10	
01097224	Pala/Blade BM-CHEF-AMX 20	
01161038-1	Pala/Blade BM-CHEF-AMX 30	
01095216	Pala/Blade BM-CHEF-AMX 40	
01101245	Pala/Blade BM-CHEF 60	
87101158-1	Pala Inox/Stainless steel Blade BM 80	
01175092	Spirale/Spiral CHEF 7,5	
01098164	Spirale/Spiral BM-CHEF-AMX 10	
01097223	Spirale/Spiral BM-CHEF-AMX 20	
01161039-1	Spirale/Spiral BM-CHEF-AMX 30	
01095217	Spirale/Spiral BM-CHEF-AMX 40	
01101246	Spirale/Spiral BM-CHEF 60	
01101157-1	Spirale inox/Stainless steel Spiral BM 80	





## Accessori per planetarie Planetary Mixers Accessories



Codice Code	Descrizione Description	
01175043	Raschiatore/Scraper CHEF 7,5	
00003319	Gruppo raschiatore /Scraper BM-CHEF-AMX 10	
00003317	Gruppo raschiatore /Scraper BM-CHEF-AMX 20-30	
00003322	Gruppo raschiatore/Scraper BM-CHEF-AMX 40	
00003323	Gruppo raschiatore/Scraper BM-CHEF 60	
00003325	Gruppo raschiatore/Scraper BM 80	
00003281	Kit planet. Vasca + attrezzi 10 su 20 - Planetary KIT bowl + tools 10/20	
00003282	Kit planet. Vasca + attrezzi 20 su 30 - Planetary KIT bowl + tools 20/30	
00003283	Kit planet. Vasca + attrezzi 20 su 40 - Planetary KIT bowl + tools 20/40	
00003285	Kit planet. Vasca + attrezzi 40 su 60 - Planetary KIT bowl + tools 40/60	
00003289	Kit planet. Vasca + attrezzi 60 su 80 - Planetary KIT bowl + tools 60/80	
00003286	Vasca planetaria/Stainless steel bowl CHEF 7,5	
04098109	Vasca planetaria/Stainless steel bowl BM-CHEF-AMX 10 260X229	
04200043-1	Vasca planetaria/Stainless steel bowl BM-CHEF-AMX 20	
04161001	Vasca planetaria/Stainless steel bowl BM-CHEF-AMX 30 350X365	
04095122-2	Vasca planetaria/Stainless steel bowl BM-CHEF-AMX 40 400X376	
04101120-1	Vasca planetaria/Stainless steel bowl BM-CHEF 60 455X435	
04101156-2	Vasca planetaria/Stainless steel bowl BM 80 480X506	
01161036	Carrello per vasca/Trolley for bowl BM-CHEF-AMX 30	
32020859	Carrello per vasca/Trolley for bowl BM-CHEF-AMX 40	
32020590	Carrello per vasca/Trolley for bowl BM-CHEF 60	
01101168	Carrello inox per vasca/Stainless steel trolley for bowl BM 80	
04101263-2	Vasca con ruote/Bowl with wheels BM-CHEF-AMX 60	
04101255-2	Vasca con ruote/Bowl with wheels BM-CHEF-AMX 80	

## Accessori per planetarie Planetary Mixers Accessories



Codice Code	Descrizione Description	
00003318	Gruppo riduttore/Reducer BM-CHEF 20-30	
51010111	Gruppo riduttore/Reducer BM-CHEF 40-60-80	
00003501	Tagliaverdure con disco regolabile/Vegetable slicer with Adjustable disk	
31000156	Disco cubettatrice + 2 trafilie/Dicing & cutting disk + 2 die plates	
31000157	Disco fette regolabile/Adjustable Slicing disk (0,5 - 5 mm)	
31000155	Disco granulare/Grinding disk mm 4	



Taglio alla Julienne  
Grinding disk



Taglio a cubetti  
Dicing & cutting disk













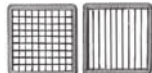
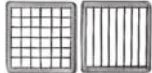

Taglio a fette  
Slicing disk



## Accessori per planetarie Planetary Mixers Accessories



Codice Code	Descrizione Description	
31000041	Tagliacubettatrice (senza dischi e trafilè) Dicing & cutting (without disk and die plate)	
31000922	Trafilà cubetti/Die plates for cubes mm 9x9x9	
31000923	Trafilà cubetti/Die plates for cubes mm 13x13x9	
31000924	Trafilà cubetti/Die plates for cubes mm 19x19x9	
31000780	Trafilà strisce/Die plates for strips mm 7x9	
31000784	Trafilà strisce/Die plates for strips mm 10x9	
31000921	Trafilà strisce/Die plates for strips mm 13x9	
00003500	Tritacarne con 2 trafilè, 2 coltelli e 1 pestello Meat mincer with 2 blades, 2 knives and 1 pestle	
31000183	Passatutto con tritacarne/Tomato juice extractor with meat mincer PS 12	
31000037	Grattugia/Cheese grater	
31000069	Tirasfoglia/Dough roller	
31000070	Tagliapasta/Dough cutter mm 1,5	
31000071	Tagliapasta/Dough cutter mm 2	



## Pasticceria Pastry & Confectionary



### “RF300”

Raffinatrice a 2 cilindri  
2 cylinders Grinding machine



Modello Model	KW	Peso Weight (Kg)	Alimentazione Voltage	Dimensioni Dimension (mm)
RF300	1,10	190	400/3/50	692X640X1150



Raschiatori  
Scrapers



Tramoggia  
Hopper



Griglia di protezione  
Protection grid

### CARATTERISTICHE TECNICHE GENERALI GENERAL TECHNICAL CHARACTERISTICS

- Cilindri in granito
- Spalle in ghisa
- Ingranaggi cementati e temperati
- Apertura max cilindri mm. 6
- Rulli con velocità asincrona
- Protezione antinfortunistica
- Normativa CE
- Certificazione GOST
- Granite cylinders
- Cast iron shoulders
- Hardened, tempered and rectified gears in oil bath
- Max cylinders opening mm 6
- Asynchronous speed cylinders
- Safety protection
- CE rules
- GOST certification

### OPTIONALS

- Tensioni speciali
- Cilindro posteriore oscillante
- Special tensions
- Rear oscillating cylinder



Come il modello Plus la RF300 è una macchina raffinatrice robusta e semplice, dotata di cilindri in granito da 300 mm, spalle in ghisa, ingranaggi cementati, temperati e rettificati. La sua pulizia è estremamente semplice grazie alla possibilità di smontare facilmente i raschiatori. L'apertura massima dei cilindri è di 6 mm e la loro differente velocità consente di raffinare al meglio tutti i prodotti granulati. Le vaschette raccogli prodotto ed i carter laterali sono in acciaio inox; la tramoggia di carico è in materiale atossico ed è protetta da una griglia. I suoi 190 kg di peso indicano una macchina molto solida, concepita per durare negli anni. È dotata di ruote per facili spostamenti.



As the Plus version, the RF300 is a sturdy and simple grinder, equipped with 300 mm cylinders in granite, abutments in cast iron, hardened, casehardened and rectified gears. It is very easy to clean as the scrapers can be dismantled without any difficulties. All granulated products can be grinded at best, thanks to the 6 mm max span of the cylinders and their different speeds. The collector basin and the lateral cases are in stainless steel; the charging hopper is in non-toxic material and is protected by a grid. Its weight of 190 kg is a sign of a very sturdy and long-lasting machine. It is equipped with wheels to move it easily.



Comme le modèle Plus la RF300 est une broyeuse solide et simple, équipée de cylindres en granit de 300 mm, de panneaux arrière en fonte, des engrenages cimentés, trempés et rectifiés. Son nettoyage est extrêmement simple grâce à la possibilité de démonter facilement les racleurs. L'ouverture maximum des cylindres est de 6 mm et leur vitesse différente permet de raffiner au mieux tous les produits granulés. Les petits bacs de recueil de produit et les carters latéraux sont en acier inoxydable; la trémie de chargement est en matériel non toxique, de plus elle est protégée par une grille. Ses 190 kg indiquent une machine très solide, conçue pour durer des années. Elle est équipée de roues pour des déplacements faciles.



Wie das Modell Plus ist auch RF300 eine widerstandsfähige und einfach zu bedienende Mahlmaschine; sie ist mit Zylindern aus Granit von 300 mm, mit Verstreben aus Gusseisen sowie eingesetztem, gehärtetem und geschliffenem Getriebe ausgestattet. Die Reinigung ist extrem einfach, da die Schaber leicht abmontiert werden können. Der weite maximale Auszug der Zylinder von 6 mm und die variierende Geschwindigkeit ermöglichen ein optimales Zerkleinern von gekörnten Produkten. Die Produktsammelbehälter und die seitlichen Gehäuse sind aus Inox-Stahl, der Ladetrichter aus atoxischem Material und durch ein Gitter geschützt. Das Gewicht von 190 kg weist auf eine widerstandsfähige Maschine hin, die für eine hohe Lebensdauer ausgelegt ist. Sie besitzt Räder und kann daher leicht verstellt werden.



Como el modelo Plus, la RF300 es una máquina refinadora sólida y simple, con cilindros de granito de 300 mm, paletas de hierro, engranajes cementados, templados y rectificadas. Su limpieza es extremadamente simple gracias a la posibilidad de desmontar con facilidad los raspadores. La apertura máxima de los cilindros es de 6 mm y sus diferentes velocidades permite refinar lo mejor posible los productos granulados. Las cubas recolectoras de producto y los cárteres laterales son de acero inoxidable; la tolva de carga es de material atóxico y está protegida por una rejilla. Los 190 Kg de peso indican que se trata de una máquina sólida, concebida para durar a través de los años. Presenta ruedas para facilitar los desplazamientos.



Как и модель PLUS, модель RF300 является прочным и простым в обращении измельчителем, оснащенным гранитным цилиндром 300 мм, опорами из чугуна, усиленным, в усиленном корпусе и с заземленным механизмом. Ее очень просто чистить, поскольку скребки легко снимаются. Все гранулированные продукты можно успешно измельчить благодаря максимальному зазору между цилиндрами в 6 мм и разнице их скоростей. Емкость для сбора измельченного продукта и боковые панели изготовлены из нержавеющей стали. Загрузочная воронка – из нетоксичного материала и защищена решеткой. Вес машины составляет 190 кг, что говорит о ее большой прочности и долговечности. Она оснащена колесами для облегчения передвижения.



## Pasticceria Pastry & Confectionary



### “Cuocicrema”

Cuocicrema a gas  
Cream cookers with gas burner



Modello Model	KW	Peso Weight (Kg)	Alimentazione Voltage	Vasca Bowl (Lt.)	Dimensioni Dimension (mm)
CC30/2	0,37	70	400/3/50	30	800X600X1300
CC50/1	0,37	85	400/3/50	50	800X600X1300
CC50/2	0,37	85	400/3/50	50	800X600X1300

#### CARATTERISTICHE TECNICHE GENERALI GENERAL TECHNICAL CHARACTERISTICS

- Vasca basculante
- Pala in acciaio inox con raschiatori
- Cinematismi su cuscinetti a sfera pre-lubrificati
- Doppia vasca inox con olio termico
- Normative CE
- Horizontally pivoted bowl
- Stainless steel blade with scrapers
- Kinematic motions on pre-lubricated ball bearings
- Double stainless steel bowl with thermic oil inside
- CE rules

#### OPTIONALS

- Tensioni speciali
- Versione inox
- Special tensions
- Inox version



Il cuocicrema a gas è adatto per piccoli e medi laboratori di pasticceria e trova applicazione nella preparazione di tutte le creme a caldo. E' composto da una vasca di acciaio inossidabile provvista di intercapedine riempita di olio termico, da un attrezzo agitatore anch'esso di acciaio inossidabile e da un robusto basamento che racchiude gli organi di movimento e l'apparecchiatura elettrica. Un grosso bruciatore garantisce un rapido riscaldamento che è controllabile attraverso l'apposito termometro di cui la vasca è provvista. Tutto il gruppo vasca è montato su supporti girevoli in modo da consentire un facile svuotamento agendo sull'apposita leva. Particolare cura è stata posta nella realizzazione dei sistemi di sicurezza rendendo la macchina conforme alle normative vigenti.



Der Cremekocher mit Gasbetrieb eignet sich für kleine und mittlere Konditorküchen und wird bei der Herstellung von allen warmen Cremes eingesetzt. Er besteht aus einer Edelstahlwanne mit Zwischenwänden, die mit Thermoöl aufgefüllt sind, ferner aus einem Rührwerkzeug, ebenfalls aus Edelstahl, und aus einem robusten Sockel, in dem Bewegungselemente und die elektrische Apparatur untergebracht sind. Ein großer Brenner garantiert eine schnelle Erwärmung, die über ein entsprechendes Thermometer der Wanne kontrollierbar ist. Die ganze Wannengruppe ist auf drehbare Halterungen montiert, um ein einfaches Entleeren über den entsprechenden Hebel zu ermöglichen. Ein Minutenzähler mit Tonausgabe warnt den Bediener, wenn die Garung beendet ist. Besonderes Augenmerk wurde auf die Herstellung der Sicherheitssysteme gelegt, was die Maschine in Übereinstimmung mit den geltenden Richtlinien bringt.



Our gas cooker is suitable for preparing any hot creams in small and medium confectioneries. It is composed of a stainless steel bowl with a hollow space filled with thermal oil, of a stainless steel mixing tool and of a strong base containing the movement controls and the electrical equipment. The rapid heating is guaranteed by a large burner which can be controlled by means of an appropriate thermometer supplied with the bowl. The entire bowl unit is mounted on revolving supports to allow easy emptying by using the suitable lever. A timer sounds to warn the operator when the cooking process has been completed. Great care has been given to the carrying out of the safety devices so that the machine complies with the regulations in force.



El cocedor de crema a gas es apto para pequeños y medianos laboratorios de pastelería, y se aplica en la preparación de todas las cremas en caliente. Esta compuesto por una cuba de acero inoxidable con doble fondo llena de aceite térmico, con una herramienta agitadora también de acero inoxidable y con una base sólida que reúne los órganos de movimiento y los equipos eléctricos. Un fuerte quemador garantiza el rápido calentamiento que se puede controlar mediante un apropiado termómetro que presenta la cuba. Todo el grupo de cuba está montado sobre soportes giratorios para permitir el fácil vaciado con la palanca apropiada. Un cuentaminutos con dispositivo sonoro advierte al operador sobre la cocción. Se ha puesto especial atención a la realización de sistemas de seguridad que hacen que la máquina se encuentre dentro de las normas vigentes.



Notre gaz cuiseur à crème est désigné pour petites et moyennes pâtisseries pour la préparation de toutes les crèmes à chaud. Il est composé d'une cuve en acier inoxydable dotée d'un interstice rempli d'huile thermique, d'un agitateur en acier inoxydable et d'une base robuste qui renferme les organes de mouvement et les dispositifs électriques. Un gros brûleur garantit un chauffage rapide qui peut être contrôlé à l'aide d'un thermomètre spécial dont la cuve est équipée. Tout le groupe cuve est monté sur des supports pivotants pour permettre un vidage aisé au moyen du levier prévu à cet effet. Une minuterie à sonnerie avise l'opérateur quand la cuisson est achevée. Un soin tout particulier a été apporté à la réalisation des dispositifs de sécurité, le résultat est une machine conforme aux règles en vigueur.



Наша газовая варочная машина подходит для приготовления любых горячих кремов в небольших и средних кондитерских. Она состоит из емкости из нержавеющей стали с «рубашкой», заполненной термостойким маслом, перемешивающего рабочего органа из нержавеющей стали и прочной станины с панелью управления и электрооборудованием. Быстрый нагрев гарантирован большой горелкой, контроль за которой осуществляется с помощью термометра, поставляемого вместе с емкостью. Емкость установлена на вращающиеся крепления, позволяющие очень просто выгрузить продукт с помощью рукоятки. Звонок таймера предупреждает оператора, когда процесс приготовления завершен. Большое внимание было уделено устройствам безопасности, чтобы машина соответствовала существующим нормам.



## Pasticceria Pastry & Confectionery



### “Electric Cookers”

Cuocitori elettrici  
Electric cookers



Modello Model	KW	Peso Weight (Kg)	Alimentazione Voltage	Vasca Bowl (Lt.)	Dimensioni Dimension (mm)
EC30	4,20	120	400/3/50	30	740X700X1360
EC60	6,45	135	400/3/50	60	740X760X1360

#### CARATTERISTICHE TECNICHE GENERALI GENERAL TECHNICAL CHARACTERISTICS

- Costruzione interamente in acciaio inox
- Riscaldamento elettrico
- Doppia vasca inox con olio termico
- Motore a due velocità
- Pala in acciaio inox con raschiatori
- Controllo elettronico della temperatura
- Vasca estraibile basculante
- Normative CE
- Stainless steel construction
- Electric heating
- Double stainless steel bowl with thermic oil inside
- Two speeds motor
- Stainless steel blade with scrapers
- Electronic control heating system
- Horizontally pivoted removable bowl
- CE rules

#### OPTIONALS

- Tensioni speciali
- Rubinetto di scarico prodotto
- Velocità regolabile
- Dosatrice volumetrica per invasettamento
- Special tensions
- Discharging cock with ball valve
- Speed control
- Volumetric dosing pump



I cuocitori elettrici sono atti alla preparazione e cottura di svariate tipologie di prodotti: dalle creme alle marmellate, dall'impasto per bignè al latte condensato, dalla besciamella alla polenta, dai ragù di carne, di funghi, di verdure, ai risotti e tanti altri prodotti. Esistono in varie versioni, con semplice movimento di un utensile oppure con movimento planetario di due utensili contemporaneamente, a 1, 2 velocità fisse o con variatore elettronico, con struttura opportunamente rinforzata sono ottime nella preparazione dell'impasto per torrone sia morbido che duro. Dal punto di vista tecnico, si tratta di macchine costruite completamente in acciaio inox rigorosamente alimentare, che sfruttano il principio della cottura a "bain-marie" con vasca a tripla parete ed intercapedine in bagno d'olio diatermico, rispondenti alle norme CE, dotate di protezioni antinfortunistiche che ne rendono l'uso semplice e sicuro. L'utensile mescolatore centrale è dotato di raschiatori a lato e fondo vasca, per evitare ogni incollamento del prodotto alle pareti della vasca, il movimento tradizionalmente in senso orario, può essere richiesto anche su comando a senso antiorario qualora le tipologie degli impasti da preparare lo richiedano. Il controllo della temperatura di cottura avviene tramite un termostato elettronico che è possibile integrare con timer per temporizzare il funzionamento delle resistenze e dell'utensile mescolatore. L'applicazione su richiesta del programmatore di cicli di lavoro, e la possibilità di scegliere dalla capacità 30 fino alla 200 lt, completano veramente il quadro fornendo così uno strumento di lavoro aperto a tutte le necessità: dalla pasticceria alla gastronomia.



Electric cookers essential in the food industry for preparing and cooking a variety of types of products: to name just a few, from creams, jams, cream puff dough, condensed milk, béchamel sauce, polenta and risottos to meat, mushroom and vegetable sauces. They are available in several versions with the simple movement of one tool or with the planetary movement of two tools at the same time. They come in 1 or 2 fixed speeds or with electronic variator, and with the structure properly reinforced, they are excellent for preparing both soft and hard almond nougat mixture. From the technical viewpoint, these machines are completely built in stainless steel suitable for alimentiation. They make use of the "bain-marie" cooking concept, with a triple-wall tank with hollow space in a diathermic oil bath to meet the EC standards, and are equipped with accident-prevention protections that make their use simple and safe. The central mixing tool is fitted with scrapers on the sides and bottom of the tank to prevent the product from adhering to the walls of the tank. Its traditional clockwise movement can be substituted with anti-clockwise movement upon command, should the types of dough to be prepared require it. The cooking temperature is controlled by an electronic thermostat that can be integrated with a timer for timing operation of the heating elements and the mixing tool. Application of the work cycle programmer upon request and the possibility to choose capacities ranging from 30 to 200 l truly complete the picture, thus providing a work tool for all needs, from patisserie to gastronomy.



Cuiseurs électriques indispensables dans l'industrie alimentaire, utilisés pour la préparation et la cuisson de différents types de produits: des crèmes aux confitures, de la pâte à chou au lait condensé, de la béchamel à la polenta italienne, des ragoûts de viande, de champignons, de légumes, aux risottos, pour n'en citer que quelques-uns. Ce sont des machines extrêmement polyvalentes, qui existent en différentes versions, avec simple mouvement d'un ustensile ou bien avec mouvement planétaire de deux ustensiles simultanément, à 1, 2 vitesses fixes ou avec variateur électronique; dotées d'une structure opportunément renforcée, elles sont l'idéal pour préparer la pâte pour le nougat dur ou mou. D'un point de vue technique, il s'agit de machines entièrement construites en acier inoxydable pour l'alimentation, qui exploitent le principe de la cuisson au "bain-marie" avec cuve avec triple paroi à chemise avec bain d'huile diathermique, conformes aux normes CE, munies de dispositifs de protection pour la prévention des accidents garantissant une utilisation simple et sûre. Le bras mélangeur central est équipé de racleurs pour les côtés et le fond de la cuve, pour éviter l'adhérence du produit contre les parois de la cuve; le mouvement, qui est traditionnellement fourni dans le sens des aiguilles d'une montre, peut être demandé également dans le sens inverse aux aiguilles d'une montre si les types de mélanges à préparer l'exigent. Le contrôle de la température de cuisson se produit par l'intermédiaire d'un thermostat électronique qui peut être intégré avec un temporisateur pour temporiser le fonctionnement des résistances et du bras mélangeur. L'application sur demande du programmatore de cycles de travail et la possibilité de choisir la capacité entre 30 et 200 l, complètent vraiment la gamme en fournissant ainsi un instrument de travail approprié à toutes les exigences: de la pâtisserie à la gastronomie.



Elektrokocher sind für die Zubereitung der verschiedensten Produkte in der Lebensmittelindustrie unentbehrlich. Diese Geräte sind äußerst vielseitig, möglich sind 1/2 feststehender Geschwindigkeiten oder eine elektronische Geschwindigkeitsregelung, mit entsprechend verstärkter Struktur sind diese Geräte optimal geeignet für die Zubereitung von festen Teigmassen wie hartem und weichem Torrone. Technisch gesehen, bestehen diese Geräte vollständig aus rostfreiem, für die Lebensmittelindustrie geeignetem Stahl und nutzen über die Wanne mit dreifacher Wand und Zwischenraum mit Wärmeträgeröl das Prinzip des Garens im „Wasserbad“. Die Geräte entsprechen den EU-Normen und sind mit Schutzvorrichtungen ausgestattet, die ihren Gebrauch einfach und sicher machen. Das zentrale Rührgerät verfügt über Kratzer an den Seiten und am Boden der Wanne, damit das Produkt sich nicht in der Wanne absetzt. Die gewöhnlicherweise im Uhrzeigersinn erfolgende Bewegung kann auf Befehl entsprechend des gewünschten Produkts auch entgegengesetzt Uhrzeigersinn ausgeführt werden. Die Steuerung der Gartemperatur erfolgt über ein elektronisches Thermostat, das mit einer Zeitschaltuhr ausgestattet werden kann, um den Betrieb der Heizwiderstände und des Rührgeräts zeitlich zu regeln. Die durch die BedienerInnen einstellbaren Arbeitszyklen und die Wahlmöglichkeit des Fassungsvermögens zwischen 30 und 200 l vervollständigen das Produkt.



Cocedores eléctricos son aptos para preparar y cocer varios tipos de productos. Existen en varias versiones, a 1, 2 velocidades fijas o con variador electrónico; con estructura oportunamente reforzada son óptimas para preparar el amasijo para turrón blando o duro. Desde el punto de vista técnico, se trata de máquinas fabricadas por completo en acero inoxidable rigurosamente alimenticio, que aprovechan el principio de cocción a "baño de maría" con cuba de triple pared de doble fondo en baño de aceite diatérmico, que se ajustan a las normas CE, y que presentan protecciones contra accidentes que permiten el uso simple y seguro. La herramienta mezcladora central presenta raspadores laterales y en el fondo de la cuba, para evitar que se pegue el producto a las paredes. El movimiento tradicionalmente en el sentido de las agujas del reloj se puede solicitar también en el sentido opuesto si los tipos de amasijos que se deben preparar lo requieren. El control de la temperatura de cocción se realiza con un termostato electrónico que se puede integrar con temporizador para medir el funcionamiento de las resistencias y de la herramienta mezcladora. La aplicación a pedido del programador de ciclos de trabajo, y la posibilidad de elegir desde una capacidad de 30 a 200 l, completan en realidad el cuadro.



Машины варочные электрические необходимы в пищевой промышленности для приготовления и варки различных видов продуктов. Это – чрезвычайно универсальные машины разных видов с использованием простого движения одного или планетарного движения двух рабочих органов одновременно. Они могут работать на 1 или 2 скоростях или с использованием вариатора скорости. Эти машины прекрасны для приготовления мягких и твердых миндальных смесей нуги. С технической точки зрения эти машины полностью изготовлены из нержавеющей стали для пищевого применения. Они используют метод «bainmarie» (рубашку) с трехстенным котлом с полостями между стенками, заполненными диатермическим маслом, и оснащены средствами защиты от несчастных случаев для простой и безопасной работы. Центральный рабочий орган оснащен скребками с боков и снизу для предотвращения прилипания продукта к стенкам котла. Его традиционное вращение по часовой стрелке может быть по запросу заменено на вращение против часовой стрелки, если для приготовления определенных видов теста требуется именно такое вращение. Электронный термостат осуществляет контроль температуры приготовления продуктов, который может работать вместе с таймером для временной регулировки работы нагревательных элементов и перемешивающего рабочего органа. Картину дополняет также возможность программного обеспечения рабочего цикла с помощью программатора как опции, а также выбора объема котла вместимостью от 30 до 200 литров.





## Pasticceria Pastry & Confectionary



### “Sfogliatrici” Sheeters



Modello Model	KW	Peso Weight (Kg)	Alimenta- zione Voltage	Dimensioni aperta Dimension opened (mm)	Dimensioni chiusa Dimension closed (mm)	Dimensione tappeto Carpet dimension (mm)
SFG 500 B	0,55	142	400/3/50	2035X955X612	750X955X825	500X700
SFG 500 T	0,55	170	400/3/50	2035X955X1270	750X955X1482	500X700
SFG 500 TM	0,55	185	400/3/50	2990X955X1270	1100X955X1920	500X1180
SFG 600 TM	0,75	232	400/3/50	2990X1055X1270	1100X1055X1920	595X1180
SFG 600 TMM	0,75	260	400/3/50	3840X1055X1270	-	595X1600
SFG 600 TL	0,75	300	220/1/50	3415X1055X1270	-	con gruppo taglio with cutting device

### CARATTERISTICHE TECNICHE GENERALI GENERAL TECHNICAL CHARACTERISTICS

- Cilindri di laminazione rettificati e lucidati al cromo duro Ø 73
- Tappeti a velocità differenziata
- Raschiatori universali e reversibili
- Apertura max cilindri mm 48
- Tavoli rialzabili e smontabili
- Spalle in alluminio anticorrosivo
- Inverter monofase
- Normative CE
- Certificazione GOST
- Misure triangoli per taglia croissant: mm 60x80/80x100/140x130/140x180
- Certificazione ETL e GOST
- Rolling cylinders ground and polished in hard chrome Ø 73
- Belts with different speeds
- Universal and reversible scrapers
- Max cylinders opening mm 48
- Rising and dismantable arms
- Bored shoulders in anticorrosive steel
- Single-phase inverter
- GOST certification
- CE rules
- Triangle size for cutting device: mm 60x80/80x100/140x130/140x180
- ETL and GOST certification

### OPTIONALS

- Tensioni speciali
- Rulli per tagli tondi o quadrati
- Special tensions
- Rollers for round or square cuts





SFG 600 e 500 è il nome della nuova linea di sfogliatrici per artigianato sviluppate da Sigma. I cilindri di grande diametro, una meccanica assolutamente affidabile e collaudata, insieme ad una linea estetica gradevole e facilmente pulibile fanno di queste macchine la massima espressione dell'efficacia e della funzionalità. Spalle in alluminio anticorrosione, cuscinetti a sfera su tutti i movimenti, raschiatori inferiori e superiori intercambiabili e reversibili, comando morbido e preciso distinguono questa serie dalle precedenti. Possono laminare qualsiasi pasta alimentare, ottenendo spessori sottili e costanti, garanzia di uniformità nei prodotti cotti. Le macchine vengono fornite con apparecchiatura elettrica in bassa tensione, ruote bloccabili per la migliore movimentazione, tappeti rialzabili per il contenimento dell'ingombro a macchina in riposo, raschiatori smontabili facilmente per l'ordinaria pulizia. Particolarmente curato l'aspetto ergonomico funzionale. La manutenzione è ridotta a quella della normale pulizia e controllo periodico.



SFG 600 und 500 sind die letzten zwei Modelle von Walzmaschinen der Firma SIGMA. Die Zylinder mit grossem Durchmesser, eine hochzuverlässige und getestete Mechanik, zusammen mit einem schönen Design und einer einfachen Reinigung, machen aus diesen Maschinen die höchste Expression von Funktionalität und Zuverlässigkeit. Schultern aus Acorodal- Aluminium, Kugellager auf allen Bewegungen, austauschbare und umkehrbare untere und obere Abschaber, genaue und bequeme Steuerung unterscheiden diese Serie von den vorherigen. Sie können jeden Teig walzen und dünne und gleichmässige Dicken erzielen, was in gekochten Produkten eine Garantie der Gleichmässigkeit ist. Die Maschinen werden mit elektrischer Vorrichtung in Niederspannung nach den letzten Vorschriften geliefert, montieren sperrbare Räder für eine bequemere Bewegung, aufhebbare Teppiche für einen reduzierten Raumbedarf wenn die Maschine ausser Betrieb ist, sowie einfach abmontierbare Abschaber für eine sorgfältige Reinigung. Die Struktur ist ergonomisch und praktisch. Die Wartung ist minimal und reduziert sich auf die Reinigung und auf die periodischen Kontrollen.



SFG 600 and 500 is the name of the new sheeters' line for artisanship created by Sigma. The cylinders with a big diameter, a very reliable and tested mechanics together with a pleasant and easily cleanable aesthetic line are the expression of the efficiency and functionality of these machines. Bored shoulders in anti-corrosion steel, ball bearings on all movements, universal and reversible scrapers, soft and precise control are the major differences of these sheeters compared to the previous ones. They can roll all kind of alimentary dough, obtaining thin and constant thickness, guarantee of uniformity in the cooked products. The machines are supplied with a low tension electric control panel, blocking wheels for a better movement, rising belts to limit the encumbrance of the machine, easily removable scrapers for the ordinary cleaning. The ergonomic and functional aspect is particularly cared, the maintenance is reduced to the normal cleaning and to a periodical checking.



SFG 600 y 500 es el nombre de la nueva línea de laminadoras para artesanado evolucionadas por Sigma. Los cilindros de grande diámetro, una mecánica absolutamente fiable y probada, junto a una línea estética agradable y fácilmente limpiable hacen de estas máquinas la máxima expresión de la eficiencia y funcionalidad. Lados de aluminio anticorrosión, rodamientos de bola en todos los movimientos, raspadores inferiores y superiores intercambiables y reversibles, mando suave y preciso distinguen a esta serie de las antecedentes. Pueden laminar cualquiera masa alimenticia, obteniendo espesores delgados y constantes, garantía de uniformidad en los productos cocidos. Las máquinas se entregan con equipo eléctrico de baja tensión conforme a normativas, ruedas blocables para una mejor movilidad, filtros alzables para la contención de las dimensiones con máquina en reposo, raspadores desmontables fácilmente para la ordinaria limpieza. Especialmente cuidado el aspecto ergonómico funcional, el mantenimiento es reducido, sólo la normal limpieza y control periódico.



SFG 600 et 500 est le nom donné à la nouvelle ligne des laminoirs pour l'artisanat et développée par Sigma. Des cylindres ayant un grand diamètre, une mécanique absolument fiable et dûment essayée, unis à une ligne esthétique agréable et facile à nettoyer font de cette machine l'expression maximum de l'efficacité ainsi que de la fonctionnalité. Les butées en aluminium anticorrosion, les roulements à billes sur tous les mouvements, les racleurs inférieurs et supérieurs interchangeables et réversibles, les commandes souples et précises distinguent cette série des précédentes. Elles peuvent feuilletter n'importe quelle pâte alimentaire, en obtenant des épaisseurs fines et constantes, en garantissant ainsi l'uniformité des produits cuits. Les machines sont fournies avec des équipements électriques en basse tension, des roues bloquants pour obtenir une meilleure manutention, des tapis relevants afin de contenir l'encombrement de la machine quand elle ne travaille pas, des racleurs faciles à démonter pour effectuer le nettoyage ordinaire. L'aspect ergonomique et fonctionnel est spécialement soigné, l'entretien est réduit seulement au nettoyage normal et au contrôle périodique.



Фирма СИГМА сконструировала модели SFG 600 и 500, которые являются моделями новой серии раскаточных машин для небольших пекарен. Цилиндры большого диаметра, очень надежные и проверенные механизмы и внешне эстетично выглядящие машины, которые можно удобно и легко почистить, являются выражением эффективности и функциональности этих машин. Фланцы из антикоррозионной стали, подшипники на всех движущихся узлах, универсальные и двусторонние скребки, плавная и точная система управления являются основными отличиями этих раскаточных машин по сравнению с предыдущими моделями. Они могут раскатывать все виды пищевого теста, производя тонкое тестовое полотно с равномерной толщиной, и гарантировать однородность приготовленного продукта. Машины оснащены электрической панелью управления с низким напряжением, колесами для удобного передвижения с блокировкой, подъемными ремнями для ограничения препятствий, легко снимаемыми скребками для обычной чистки. Особое внимание было уделено эргономичным и функциональным аспектам, а техническое обслуживание сведено до обычной чистки и периодической проверки.



# Pizza



**34 Tauro**  
Impastatrici a spirale a vasca fissa da banco  
Bench Spiral Mixers with fixed bowl



**38 Divider-rounders**  
Spezzarrotondatrici da banco  
Bench Divider-rounders



**42 Sfera**  
Arrotondatrice a coclea  
Screw Rounder



**44 Sprizza**  
Stenditrici a freddo per pizza  
Cold system Pizza spinner



**46 Sfogliatrice verticale**  
Vertical sheeter







Pizza



## “Tauro”

Impastatrici a spirale a vasca fissa da banco  
Bench Spiral Mixers with fixed bowl



### CARATTERISTICHE TECNICHE GENERALI GENERAL TECHNICAL CHARACTERISTICS

- Vasca, spirale, piantone, grigliato in acciaio inox
- Cinematismi su cuscinetti a sfera pre-lubrificati
- Pannello comandi frontale a tenuta stagna (escluse TAURO 12 e 18)
- Vasca con fondo molto arrotondato
- Trasmissione con cinghie dentate inestensibili
- Normative CE
- Certificazione GOST

- Stainless steel bowl, spiral, shaft and grid
- Kinematic motion on pre-lubricated ball bearings
- Frontal control panel with watertight seals (Tauro 12 and 18 not included)
- Well rounded bottom bowls
- Transmission with inextensible toothed belts
- CE rules
- GOST certification

### OPTIONALS

- Tensioni speciali
- Tappo vasca
- Versione inox
- Special tensions
- Drain bowl cap
- Stainless steel version



Modello Model	KW	Peso Weight (Kg)	Vasca Bowl (Lt.)	Diametro Vasca Bowl dimension (mm)	Dimensioni Dimension (mm)	Max farina Max flour (Kg)	Min acqua Min water (Lt.)
TAURO 12	0,55	45	16	320X210	350X540X570	7,5	4,1
TAURO 18	0,55	46	21	360X210	380X580X570	11,0	6,0
TAURO 22	0,75	67	29	400X230	400X700X800	12,5	7,5
TAURO 22 (2 Velocità/Speed)	0,8/1,1	67	29	400X230	400X700X800	12,5	7,5
TAURO 25	0,75	72	32	400X260	400X720X800	16,0	9,0
TAURO 25 (2 Velocità/Speed)	0,8/1,1	72	32	400X260	400X720X800	16,0	9,0
TAURO 30	0,75	75	41	450X260	490X750X770	18,5	10,0
TAURO 30 (2 Velocità/Speed)	0,8/1,1	75	41	450X260	490X750X770	18,5	10,0
TAURO 35	1,10	88	48	450X300	490X750X830	22,0	12,0
TAURO 35 (2 Velocità/Speed)	1,2/1,55	88	48	450X300	490X750X830	22,0	12,0
TAURO 40	1,10	96	60	500X300	530X780X830	25,0	15,0
TAURO 40 (2 Velocità/Speed)	1,2/1,55	96	60	500X300	530X780X830	25,0	15,0
TAURO 35 Automatic (2 Velocità/Speed)	1,2/1,55	88	48	450X300	490X750X910	22,0	12,0
TAURO 40 Automatic (2 Velocità/Speed)	1,2/1,55	102	60	500X300	530X780X910	25,0	15,0
TAURO 25 PLUS (2 Velocità/Speed) (Rinforzata/Heavy Duty)	1,2/1,55	75	32	400X260	440X700X770	16,0	9,0
TAURO 35 PLUS (2 Velocità/Speed) (Rinforzata/Heavy Duty)	1,2/1,55	90	48	450X300	490X750X830	22,0	12,0
TAURO 40 PLUS (2 Velocità/Speed) (Rinforzata/Heavy Duty)	1,2/1,55	100	60	500X300	530X780X830	25,0	15,0

**Ruote - Wheels**

Basamento con ruote  
Basement with wheels



# Pizza



Basamento su ruote (optional)  
Basement on wheels (optional)



TAURO 22-25-30-35-40



TAURO 35A-40A



TAURO 12-18



Le TAURO sono impastatrici classiche per la pizzeria o per piccoli impasti da pane. La forma della spirale, il rapporto del suo diametro rispetto alla vasca, insieme al numero di giri di spirale e vasca forniscono i migliori risultati d'impasto, mentre la presenza del piantone centrale migliora il rendimento dell'impastatrice. Tutte le parti a contatto con la pasta sono in acciaio inox, l'apparecchiatura elettrica di comando, semplice e funzionale è rispondente alle normative vigenti.

- Più potenti: le trasmissioni ad alto rendimento forniscono i valori di coppia sulla spirale fra i più elevati.
- Più affidabili: tutti i cinematismi girano su cuscinetti a sfera prelubrificati. Le cinghie sono inestensibili. Nessuna manutenzione è richiesta.
- Pannello e comandi con guarnizioni a tenuta stagna.
- Nuovi carter con comandi frontali "comodi e visibili".
- Grigliati in acciaio inox AISI 204.
- Vasche con fondo molto arrotondato per evitare ristagni di farina.



Es handelt sich hierbei um die klassische Knetmaschine für Pizzerien oder für kleinere Mengen an Brotteig. Die Form der Spirale und ihr Durchmesser im Verhältnis zur Wanne begünstigen zusammen mit der Anzahl an Drehungen von Spirale und Wanne die besten Ergebnisse für die Teigmasse, während die zentrale Lenksäule die Leistungskraft der Knetmaschine verbessert. Alle im Kontakt mit der Teigmasse stehenden Bauteile sind aus rostfreiem Stahl gefertigt. Die elektrische Steuervorrichtung ist einfach und funktionelle aufgebaut und entspricht den gesetzlichen Vorschriften.

- Noch leistungsfähiger: Der Hochleistungsantrieb bietet der Spirale höchstmögliche Drehmomente.
- Noch zuverlässiger: Alle Getriebe drehen auf vorgeschmiedeten Lagern. Die Riemen können nicht gedehnt werden. Es ist keine Wartung notwendig.
- Tafel und Steuerung hermetisch abgedichtet.
- Neue Gehäuse mit bequem bedienbarer und gut erkennbarer Frontalsteuerung.
- Gitter aus rostfreiem Stahl AISI 204.
- Wannen mit stark abgerundetem Boden, um Ablagerung des Mehls zu vermeiden.



TAURO are the classic kneaders for pizzeria or for mixing small quantities of bread dough. The shape of the spiral, the relationship of its diameter with the bowl, together with the spiral and bowl revolutions provide the best dough results, while the presence of the central shaft improves the efficiency of the kneading machine. All the parts in contact with the dough are in stainless steel, the control panel simple and functional respects the rules in force.

- More powerful: the efficient transmissions supply the highest torque values on the spiral.
- More reliable: all the kinematic motions turn on prelubricated bearings. The belts are inextensible. No maintenance is necessary.
- Control panel, push buttons and timer with watertight seals.
- New upper cover with "easy to use and clearly visible" frontal controls.
- Stainless steel AISI 204 grid.
- Bowl with a well rounded bottom to avoid flour stagnation.



TAURO son amasadoras clásicas para pizzería o para pequeñas masas de pan. La forma de la espiral, la relación de su diámetro con respecto a la cuba y el número de giros de la espiral y de la cuba proveen los mejores resultados de amasado; y la presencia de la columna central mejora el rendimiento de la amasadora. Todas las partes en contacto con la masa son de acero inoxidable. El equipo eléctrico es de fácil manejo y funcional conforme a las normativas vigentes.

- Más potentes: las transmisiones de alto rendimiento proporcionan muy elevados valores de pares de fuerzas.
- Más fiables: todos los cinematismos giran sobre cojinetes de rodamiento prelubricados. Las correas son inextensibles. No necesitan mantenimiento.
- Panel y mandos con guarniciones herméticas.
- Nuevo cárter con mandos frontales "cómodos y bien visibles".
- Rejillas en acero inoxidable AISI 204.
- Cubas con fondo muy redondeado para evitar cúmulos de harina.



TAURO sont des pétrins classiques pour pizzeria ou pour de petits pétrissage de pain. La forme de la spirale, son diamètre en rapport à la cuve, uni au nombre de tours de spirale et de cuve, fournissent les meilleurs résultats de pétrissage; la présence du pivot centrale améliore le rendement du pétrin. Toutes les parties en contact avec la pâte sont en acier inox. Le tableau électrique de commande répond aux normes en vigueur.

- Plus puissantes: les transmissions à grand rendement fournissent les valeurs de couple sur la spirale les plus élevés.
- Plus fiables: tous les cinématismes tournent sur des roulements à sphère pré lubrifiés. Les courroies sont inextensibles. Aucun entretien nécessaire.
- Panneau et commandes avec garnitures étanches.
- Nouveau couvercle avec commandes frontales «pratiques et bien visibles».
- Grille en acier inoxydable AISI 304.
- Cuve avec le fond bien arrondi pour éviter rétamage de farine.



Эти машины являются классическими тестомесильными машинами для пиццерий или для замеса не-большого количества теста для хлебобулочных изделий. Форма спирали, соотношение ее диаметра с размером дежи вместе со скоростью вращения спирали и дежи обеспечивают наилучшее качество теста, а наличие центрального отсекавателя увеличивает эффективность тестомесильной машины. Все части, контактирующие с тестом, изготовлены из нержавеющей стали. Панель управления - простая и функциональная, отвечает существующим требованиям.

- Более мощная: эффективная коробка передач обеспечивает наилучший крутящий момент спирального рабочего органа.
- Более надежная: все кинематические движения осуществляются на предварительно смазанных подшипниках. Ремни не растягиваются. Нет необходимости в техническом обслуживании.
- Панель управления, кнопки и таймер оснащены водонепроницаемой изоляцией.
- Новая верхняя крышка с фронтальным управлением «легко работать и наблюдать».
- Защитная решетка из нержавеющей стали AISI 204.
- Дежа с правильной округлой формой дна для предотвращения скопления муки на дне.





Pizza



## “DR 14-11 Divider-rounders”

Spezzarrotondatrici da banco  
Bench Divide-rounders



Modello Model	Descrizione Description	KW	Peso Weight (Kg)	Alimentazione Voltage	Dimensioni Dimension (mm)
D 14	SPEZZATRICE: fornita solo con gruppo di taglio da 14 pezzi e basamento. MANUAL DIVIDER D 14: Provided only with 14 sections cutting group and basement.	-	85	-	585X685X1640
D 11	SPEZZATRICE: fornita solo con gruppo di taglio da 11 pezzi e basamento. MANUAL DIVIDER D 11: Provided only with 11 sections cutting group and basement.	-	87	-	585X685X1640
DR 14	SPEZZAROTONDATRICE: fornita di 1 gruppo di taglio da 14 pezzi, telaio da 14 coppe, 2 piatti porta porzioni e bacinella inox. DIVIDER AND ROUNDER MACHINE: provided with 1 section cutting group (14 pieces) , 1 tub plate , 2 dough plates, 1 stainless stell dish.	0,30	96	220/50/1	585X685X875
DR 11	SPEZZAROTONDATRICE: fornita di 1 gruppo di taglio da 11 pezzi, telaio da 11 coppe, 2 piatti porta porzioni e bacinella inox. DIVIDER AND ROUNDER MACHINE: provided with 1 section cutting group (11 pieces), 1 tub plate , 2 dough plates, 1 stainless stell dish.	0,30	96	220/50/1	585X685X875

### ACCESSORI - ACCESSORIES

Gruppo di taglio da 14 pezzi - 14 Sections cutting group

Gruppo di taglio da 11 pezzi - 11 Sections cutting group

Telaio 14 coppette - 14 Tub plate

Telaio 11 coppette - 11 Tub plate

Piatto porta porzioni 11/14 segni - Dough plate 11/14 pieces

Bacinella inox per gruppo 14 divisioni - Stainless steel dish for 14 sections

Bacinella inox per gruppo 11 divisioni - Stainless steel dish for 11 sections

Basamento tubolare con ruote - Tubolar basement with wheels

Olio divisorio (fusto da 5 litri) - Releasing oil (5lt. Tank )



N.B. PRIMA DI ORDINARE LA DR, SPECIFICARE IL TIPO DI COPPA SCELTA (Vedi tabella sottostante)  
 N.B. PLACING THE ORDER, PLEASE SPECIFY THE KIND OF TUBS YOU NEED (See chart below)

Gruppo Taglio Section cutting group	Codice coppa Tub letter	Colore coppe Tub colour	Capacità in gr. Range weight gr. (MIN/MAX)	Capacità in onces. Range weight oz. (MIN/MAX)
14 Divisioni/Sections	A	Bianca/White	250/300	8,8 / 10,5
	B	Verde/Green	175/225	6,2 / 7,9
	C	Rossa/Red	150/200	5,3 / 7,0
	D	Bianca/White	110/150	3,9 / 5,3
	H	Bianca/White	220/260	7,8 / 9,2
11 Divisioni/Sections	E	Bianca/White	480/650	17 / 22,9
	F	Bianca/White	320/480	11,3 / 17
	G	Bianca/White	300/350	10,6 / 12,4



Gruppo taglio 14 divisioni  
Cutting group 14 sections

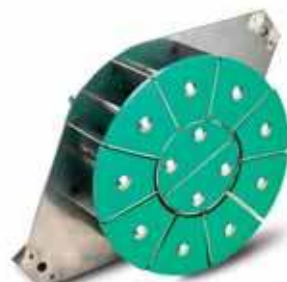

Gruppo taglio 11 divisioni  
Cutting group 11 sections



## CARATTERISTICHE TECNICHE GENERALI GENERAL TECHNICAL CHARACTERISTICS

- Taglio manuale da 14 o 11 divisioni
- Arrotondatura automatica con timer
- Normative CE
- Certificazione ETL e GOST
- Manual cutting 14 or 11 sections
- Automatic rounding with timer
- CE rules
- ETL and GOST certification

## OPTIONALS

- Tensioni speciali
- Coppette personalizzate
- Special tensions
- Customized cup size





È la più moderna sintesi dei due più antichi sistemi per spezzare e arrotondare porzioni di pasta da pane e pizza. La macchina consente, di spezzare ed arrotondare circa 800/1000 porzioni di pasta l'ora. Le porzioni possono essere da 150 a 320 gr con il gruppo taglio a quattordici divisioni e da 300 a 650 gr con il gruppo di taglio a undici divisioni. Il gruppo taglio, costruito interamente in acciaio inox, è facilmente smontabile per la sostituzione o per il lavaggio. Grazie ad un sistema di arrotondatura quanto più simile alla manualità del pizzaiolo, la pasta non subisce alcuno stress e le palline risultano sempre perfette. L'utilizzo è estremamente semplice e consente a personale non qualificato d'ottenere ottimi risultati senza alcuno sforzo fisico. Poco ingombrante e praticissima è anche incredibilmente economica.



Es ist die modernste Synthese der beiden ältesten Systeme zum Teilen und Rundformen von Brot- und Pizzateig. Die Maschine ermöglicht es, etwa 800/1000 Teigportionen pro Stunde zu teilen und zu runden. Die Portionen können 150 bis 320g beim Schneidaggregat zu vierzehn Unterteilungen und 300 bis 650g beim Schneidaggregat zu elf Unterteilungen betragen. Das Schneidaggregat besteht vollständig aus Edelstahl und ist einfach für den Ersatz oder für die Reinigung abbaubar. Dank eines Grundformsystems, das eher der Handarbeit eines Pizzabäckers ähnelt, erleidet der Teig keine Stressbehandlung und die Kugeln sind immer perfekt. Der Gebrauch ist äußerst einfach und ermöglicht es, dass auch nicht Fachpersonal beste Ergebnisse ohne Kraftaufwand erzielen kann. Es ist Platz sparend und äußerst praktisch und dazu unglaublich kostengünstig.



This machine is the most modern synthesis of the two oldest methods of cutting and rounding bread and pizza dough. The machine is able to cut and round about 800/1000 portions of dough per hour. The portions can weigh from 150 to 320 gr with the cutting group dividing into 14 sections and from 300 to 650 gr with the cutting group dividing into 11 sections. The cutting group, entirely constructed in stainless steel, is easily dismantlable for replacement or washing purposes. Thanks to a rounding system that is very similar to the manual dexterity of the pizza-maker, the dough has no stress and the balls are always perfectly round. The machine is extremely easy to use and allow unqualified personnel to achieve excellent results without employing any physical effort. Small in its dimensions and very practical this machine is also very cheap.



Es la más moderna síntesis de los dos sistemas más antiguos para cortar y redondear porciones de masa de pan y pizza. La máquina permite cortar y redondear entre 800 y 1000 porciones de masa a la hora. Las porciones pueden ser de 150 hasta 320 gr con un grupo de corte de once divisiones. El grupo de corte, fabricado enteramente en acero inoxidable, puede desmontarse sin dificultad para su sustitución o lavado. Gracias a su sistema de redondeo, muy similar a la pizza elaborada a mano, la masa no sufre ningún estrés y las bolas resultan siempre perfectas. Su fácil manejo permite a personal no cualificado conseguir resultados óptimos sin esfuerzo físico alguno. Poco voluminosa y muy práctica, resulta una máquina increíblemente económica.



Cette machine représente la synthèse la plus moderne des deux anciens systèmes utilisés pour diviser et bouler des portions de pâte à pain ou à pizza. La machine permet de diviser et de façonner 800-1000 portions de pâte/l'heure. Les portions peuvent être de 150 à 320 gr. avec le groupe de découpage ayant quatorze divisions et de 300 à 600 gr. avec le groupe de découpage ayant onze divisions. Le groupe de découpage, constitué entièrement en acier inox, est facilement démontable pour pouvoir en effectuer l'échange ou pour pouvoir le laver. Grâce à un système d'arrondissement très similaire à la dextérité d'un pizzaiolo, la pâte n'a pas de stress et les boules sont toujours parfaites. Son utilisation est très simple et elle permet même à un personnel qui n'est pas qualifié en la matière d'obtenir de très bons résultats sans aucun effort physique. Pas encombrant et très pratique elle est aussi incroyablement économique.



Эта машина является синтезом двух старых методов резки и округления теста для пиццы и хлеба. Она может резать и округлять приблизительно 800/1000 тестозаготовок в час. Вес заготовок может быть от 150 до 320 г при использовании режущей группы на 14 секций и от 300 до 650 г при использовании режущей группы на 11 секций. Режущую группу, изготовленную из нержавеющей стали, можно легко вытащить с целью замены или мойки. Благодаря системе округления, имитирующей ручную работу изготовителя пиццы, структура теста не разрушается, и шарообразные заготовки хорошо округлены. Машина чрезвычайно проста в работе и позволяет даже неквалифицированному персоналу без усилий достигать прекрасных результатов. Небольшая по габаритам и очень практичная – эта машина так же является очень дешевой.



Pizza



## “Sfera”

Arrotondatrice a coclea  
Screw Rounder



Modello Model	KW	Peso Weight (Kg)	Dimensioni Dimension (mm)	Capacità in gr. Range weight gr. (MIN/MAX)	Capacità in oncie. Range weight oz. (MIN/MAX)
Arrotondatrice SFERA	0,37	60	350X540X780	30 / 1000	01 / 35

### CARATTERISTICHE TECNICHE GENERALI GENERAL TECHNICAL CHARACTERISTICS

- Costruzione solida e robusta
- Manutenzione ridotta
- Coclee intercambiabili in alluminio
- Vassoio in uscita in acciaio inox
- Cilindro in materiale plastico certificato NSF
- Facile pulizia
- Normativa CE
- Solid and sturdy structure
- Practically maintenance-free
- Interchangeable aluminium endless screws
- Stainless steel Output Tray
- NSF certified plastic cylinder
- Easy to clean
- CE rules

### OPTIONALS

- Coclea teflonata per impasti molto delicati da pasticceria
- Tefloned endless screw for delicate pastry dough



Cilindro di arrotondatura  
Rotating cylinder



Coclea  
Endless screw



L'arrotondatrice a coclea modello "Sfera" è ideale per arrotondare porzioni di pasta di tutti i tipi da 30 gr fino a 1000 gr, sia con paste dure che con quelle morbide o molto umide. Semplicissima da usare e pratica da smontare per la pulizia, ha un consumo ridottissimo grazie all'alimentazione monofase da 220 volt. La macchina è in grado di formare più di 1800 pezzi/h e può essere utilizzata sia in pizzeria che in panificazione. Il sistema di arrotondamento sfrutta la forza di gravità e la forza centrifuga limitando al minimo la pressione sulla pasta, ciò consente di non alterarne la temperatura e l'elasticità, evitandone quindi lo stress. Costruita in acciaio inox, con un potente motore e una meccanica semplice, è una macchina molto affidabile. Il tamburo rotante in materiale plastico è certificato per un uso alimentare.



Der Schneckenrundformer Modell "Sfera" ist ideal zum Runden von Portionen aller Teigarten von 30g bis 1000g, sowohl für harten Teig als auch weichen und sehr feuchten Teig. Er ist sehr einfach zu benutzen und leicht für die Reinigung abzumontieren. Er besitzt durch eine einphasige Stromversorgung mit 220 Volt einen äußerst geringen Stromverbrauch. Die Maschine kann über 1800 Stücke/Std. formen und kann sowohl in Pizzerien als auch bei der Brotherstellung eingesetzt werden. Das Rundformsystem nutzt die Schwerkraft und die Zentrifugalkraft aus und senkt den Druck auf den Teig auf ein Minimum, wodurch die Temperatur und die Elastizität nicht verändert werden und somit Stress vermieden wird. Die Maschine besteht aus Edelstahl und besitzt einen starken Motor und eine einfache Mechanik, sie ist hierdurch sehr zuverlässig. Die Drehtrommel ist aus Plastik und für den Lebensmitteleinsatz zugelassen.



The screw rounder model "Sfera" is ideal for rounding pieces of all kind of dough from 30 gr to 1000 gr, both with hard and soft or very humid dough. Very easy to use and practical to dismount for cleaning, it has a very reduced consumption thanks to the single phase tension (220 volt). The machine is able to mould more than 1800 pieces/hour and can be used both in pizzerias and bakeries. The rounding system makes use both the gravity and the centrifugal force limiting at the minimum the pressure on the dough. This allows not to alter its temperature and elasticity avoiding the stress. Built in stainless steel, with a powerful motor and a simple mechanics, it is a very reliable machine. The rotating cylinder in plastic material is certified for alimentary use.



La boleadora espiral modelo "Sfera" es ideal para redondear porciones de masa de todo tipo de 30 a 1000gr, ya sea con masa dura o blanda incluso con las muy húmedas. Sencilísima de usar y de práctico desmontaje para su limpieza, su consumo es reducidísimo gracias a la alimentación monofase de 220v. La máquina está preparada para dar forma a más de 1800 piezas por hora y puede ser utilizada tanto para pizzería como panificación. El sistema de redondeado aprovecha la fuerza de la gravedad y la centrífuga reduciendo al mínimo la presión sobre la masa, lo que permite que no se alteren la temperatura y la elasticidad evitando así el estrés. Su fabricación en acero inoxidable, su potente motor y su mecánica sencilla la convierten en una máquina de alta fiabilidad. El tambor rotante es de material plástico certificado para uso alimentario.



La bouleuse à vis "Sfera" est idéale pour arrondir portions de pâte de toute sorte à partir de 30 gr jusqu'à 1000 gr, aussi bien avec pâtes dures que douces ou très humides. Très simple à utiliser et pratique à démonter pour le nettoyage, la bouleuse a une consommation réduite grâce à l'alimentation mono 220 volt. La machine est capable de faire plus que 1800 pièces/heures et peut être utilisée aussi bien en pizzeria qu'en boulangerie. Le système d'arrondissement utilise la force de gravité et centrifuge et limite au minimum la pression sur la pâte sans altérer la température et l'élasticité pour éviter le stress. Avec une structure en acier inoxydable, un moteur puissant et une mécanique simple, la machine est très fiable. Le cylindre pivotant, en matériel plastique, est certifié pour l'utilisation alimentaire.



Машина округлительно-закаточная модели "Сфера" является идеальной для округления тестозаготовок всех видов теста весом от 30 до 1000 г, как крутого, так и мягкого или очень влажного теста. Она очень проста в работе и практична при разборке для чистки. У нее очень низкое потребление благодаря одно- фазному напряжению (220 вольт). Машина может формировать более, чем 1800 шт/ч, и может быть использована в пиццериях и пекарнях. Система округления использует гравитационную и центробежную силу с минимальным давлением на тесто. Это позволяет не изменять его температуру, эластичность и не подвергать стрессу. Это – очень надежная машина, изготовленная из нержавеющей стали. С мощным двигателем и простым механизмом. Вращающиеся цилиндры сделаны из пластика для пищевого применения.



Pizza



## “Sprizza”

Stenditrici a freddo per pizza  
Cold system Pizza spinner



Modello Model	KW	Peso Weight (Kg)	Dimensioni Dimension (mm)
SPZ 40	0,55	120	570x720x770
SPZ 50	0,75	150	700x820x840
SPZ Automatic	0,75	120	502x728x768
Anello - Ring SPZ40		-	
Anello - Ring SPZ 50 - Automatic		-	
Tappeto - Carpet		-	
Basamento - Basement		-	
Disco in gomma - Rubber disk		Misure/Dimension Ø : 250-270-290-310-400-460 mm	

### CARATTERISTICHE TECNICHE GENERALI GENERAL TECHNICAL CHARACTERISTICS

- Lavorazione pasta a freddo
- Sistema di microrullatura brevettato
- Esecuzione del bordo pizza
- Spessore pizza regolabile
- Accensione e spegnimento automatico
- Produzione 200 - 250 pz/h
- Normative CE
- Certificazione ETL e GOST
- Cold system for spreading the pizza dough
- Patented micro-rolling system
- Execution of the edge
- Adjustable pizza thickness
- Automatic start and stop
- Capacity production 200 - 250 pcs/hr
- CE rules
- ETL and GOST certification

### OPTIONALS

- Tensioni speciali
- Special tensions



PIZZA

Versione Automatica  
Automatic Version



È la macchina che più da vicino riproduce la manualità del pizzaiolo, imitandone l'ineguagliabile delicatezza. L'originale sistema di microrullatura protetta, rigorosamente brevettato, nasce da una felice ed originale intuizione, sviluppata e concretizzata per ottenere una lavorazione della pasta simile a quella di mani esperte. L'eccezionalità della macchina consiste nel preparare la base della pizza a freddo, già con la bordatura, senza alterazioni della pasta, esattamente come farebbero le mani di un abile pizzaiolo. L'utilizzo è semplice e pratico; le forme sono sempre perfette.



Es handelt sich um die Maschine, die die Handfertigkeit des Pizzabäckers vollzieht, indem das unvergleichliche Feingefühl nachgeahmt wird. Das originale und streng patentierte System der geschützten Microrollen entsteht aus einer glücklichen Intuition, die entwickelt und umgesetzt wurde, um eine Teigbearbeitung zu erhalten, die der Bearbeitung von Experten Händen ähnlich ist. Das außergewöhnliche der Maschine besteht in der Kaltvorbereitung der Pizzabasis bereits mit der Umrandung, ohne den Teig zu verändern, gerade so wie es die Hände eines geschickten Pizzabäckers täten. Der Gebrauch ist einfach und praktisch; die Formen sind immer perfekt.



This machine reproduces the manual dexterity of the pizza-maker as closely as possible by imitating his unequalled delicateness. The original protected microrolling system, rigorously patented, results from a happy original intuition which was developed and achieved in order to knead the dough in the same way as the hands of an expert would. The exceptional performance of the machine is to achieve cold dough with the same kind of rim as would be obtained by a skilful pizza-maker, without any alteration. The machine is really easy and practical to use and the portions of dough are always perfectly flattened.



Es la máquina que más se aproxima a la elaboración a mano imitando su inigualable delicadeza. Su sistema original de micro-rotación protegido, rigurosamente patentado, deriva de una feliz y original intuición desarrollada expresamente para obtener una masa similar a la de manos expertas. Lo excepcional de la máquina consiste en la preparación de base de pizza en frío, ya con borde, sin alterar la masa, exactamente como harían las manos de un pizzero. Su manejo es simple y práctico, la forma es siempre perfecta.



C'est la machine qui reproduit le mieux le travail manuel du pizzaiolo, en imitant sa délicatesse inégalable. Le système original de micro-roulage protégé, rigoureusement breveté dans le monde entier, prend naissance d'une intuition bonne et originale qui a été développée et concrétisée pour obtenir le façonnage de la pâte semblable à celui des mains expérimentées. Le caractère exceptionnel de la machine consiste à laisser la pâte étalée avec le bord exactement comme il le serait s'il avait été fait par les mains expérimentées du pizzaiolo. Facile et pratique à employer, les formes sont toujours parfaites.



Эта машина довольно близко воспроизводит ручную работу изготовителя пиццы, имитируя его непревзойденную работу. Запатентованная система микрораскатки воссоздает счастливую оригинальную интуицию и формирует тестозаготовку аналогично рукам эксперта. Исключительная работа машины заключается в формировании края холодной тестовой заготовки пиццы так же, как это сделал бы опытный изготовитель пиццы, без нарушения структуры теста. Эта машина действительно проста и эффективна в обращении, а тестозаготовки всегда идеально ровные.



Pizza



## “Sfogliatrice Verticale”

Vertical sheeter



Modello Model	KW	Peso Weight (Kg)	Alimentazione Voltage	Dimensioni aperta Dimension opened (mm)	Dimensioni chiusa Dimension closed (mm)
Sfogliatrice verticale/Vertical sheeter T 50 modello trifase/3 phase version	0,75	60	400/3/50	760X580X600	760X400X600
Sfogliatrice verticale/Vertical sheeter T 50 modello monofase/1 phase version	0,35	60	220/1/50	760X580X600	760X400X600

### CARATTERISTICHE TECNICHE GENERALI GENERAL TECHNICAL CHARACTERISTICS

- Cilindri in acciaio cromato rettificato
- Parti a contatto in materiale atossico
- Nastri porta pasta
- Normative CE
- Maniglia di regolazione con doppio fermo min/max
- Certificazione ETL e GOST
- Laminating cylinders rectified with hard chrome
- Contacting parts in no-toxic material
- Outgoing strips
- Adjustable lever with double block min/max
- CE rules
- ETL and GOST certification



### OPTIONALS

- Tensioni speciali
- Velocità tappeto e cilindri variabile
- Special tensions
- Cloth and cylinders with variable speed



Nastri porta pasta - Outgoing strips



La sfogliatrice verticale presentata è una macchina studiata per consentire lavorazioni di laminazione di paste alimentari in ambienti di piccole dimensioni dove lo spazio è di vitale importanza; ha dimensioni contenute durante la lavorazione e può diventare estremamente compatta durante il riposo. Due cilindri d'acciaio rettificato al cromo duro, con efficaci raschiatori facilmente smontabili, garantiscono perfette laminazioni, mentre le trasmissioni particolarmente potenti consentono di lavorare paste tenaci e dure. L'apertura e la chiusura dei cilindri è comandata da una maniglia di facile uso che presenta due registri, per il minimo spessore e per il massimo spessore. Questo consente l'uso della macchina come stendipizza in doppio passaggio, permette la laminazione di pizze in teglia o di piccole quantità di pasta sfoglia. Particolarmente efficace nella lavorazione della pasta fresca, garantisce sfoglia di spessore finissimo e di grande regolarità. Particolare attenzione è stata messa nei sistemi anti-infortunistici e nei comandi perfettamente a normative vigenti, mentre la manutenzione è ridotta alla sola pulizia e controllo periodico.



Die vertikale Teigausrollmaschine ist eine Maschine, die entwickelt wurde, um die Walzbearbeitung von Lebensmittelteigen in einem eingegrenzten Arbeitsbereich zu ermöglichen, in dem Raum von außerordentlicher Bedeutung ist. Sie benötigt während des Arbeitsvorganges geringen Platz und wird bei Nichtgebrauch außerordentlich kompakt. Die mit Hartchrom geschliffenen Stahlzylinder mit wirkungsvollen und leicht abbaubaren Schabern garantieren ein perfektes Ausrollen, während die besonders starke Kraftübertragung eine Bearbeitung von Zähnen und harten Teigen zulässt. Die Öffnung und Schließung der Zylinder wird über einen einfach zu benutzenden Griff gelenkt, der zwei Regler für eine Kleinst- und eine Größtdicke. Dies ermöglicht den Gebrauch der Maschine als Teigausroller in doppeltem Durchgang, es gestattet das Ausrollen von Pizzen in die Backform oder das Ausrollen von kleinen Mengen vom Blätterteig. Die Maschine ist besonders gut für die Bearbeitung von frischem Teig geeignet, bei der die Geschwindigkeit über einen Inverter eingestellt werden kann, wodurch die Arbeiten wesentlich vereinfacht werden und ein ausgerollter Teig von äußerst geringer Dicke und überaus regelmäßig garantiert wird. Besondere Aufmerksamkeit wurde in die Unfallverhütungssysteme und in Steuerungen gelegt, die perfekt den geltenden Normen angepasst sind. Die Wartung beschränkt sich auf die Reinigung und regelmäßige Kontrollen.



The vertical pasta rolling machine presented has been designed for rolling pasta in small environments where space is at a premium. It has the advantage of being very compact during operation and becoming even more compact when it is not used. Two hardchrome ground steel cylinders, with easy-to-remove scrapers, ensure perfect rolling and the powerful driving parts permit working tenacious and hard pasta. Cylinder opening and closing is controlled by an easy-to-use handle featuring two adjusters, for minimum and maximum thickness. This means the machine can also be used to roll pizzas (double rolling), for pan baking or small quantities of puff pastry. The machine is ideal for rolling fresh pasta and allows rolling very fine sheets of extremely uniform pasta. Special focus has been placed on the accident-prevention systems and controls, which fully comply with applicable standards, while the only maintenance required is periodical cleaning and checking.



La estiradora vertical presentada es un aparato estudiado para facilitar la laminación de pastas alimenticias en lugares de pequeñas dimensiones en donde el espacio es de vital importancia. Tiene la característica de poseer dimensiones reducidas durante su uso y de volverse sumamente compacta durante el reposo. Dos cilindros de acero rectificado con cromo duro, con eficaces rascadores fácilmente desmontables, garantizan perfectas laminaciones, mientras que las transmisiones particularmente potentes permiten trabajar masas tenaces y duras. La apertura y cierre de los cilindros se acciona con una manilla de fácil uso que presenta dos ajustes, para el espesor mínimo y máximo. Esto permite utilizar el aparato para extender la pizza con doble pasada y, asimismo, para la laminación de pizza en una placa o de pequeñas cantidades de hojaldre. Particularmente eficaz en la preparación de pasta fresca garantizando una masa de espesor finísimo y de gran regularidad. Particular atención se ha puesto en los sistemas de prevención de accidentes y en los mandos que cumplen perfectamente con las normativas vigentes, mientras que su mantenimiento se reduce a la sola limpieza y control periódico.



Le laminoir vertical présenté est une machine conçue pour permettre l'étirage de pâtes alimentaires dans de petits espaces où les dimensions jouent un rôle essentiel. Ses dimensions sont très réduites pendant l'étirage et elle peut devenir très compacte lorsqu'elle est au repos. Deux cylindres d'acier rectifié au chrome dur, avec des racleurs efficaces facilement démontables, garantissent des étirages parfaits, alors que les transmissions particulièrement puissantes permettent de travailler même des pâtes tenaces et dures. L'ouverture et la fermeture des cylindres sont commandées par une poignée facile à utiliser et qui a deux réglages, un pour l'épaisseur minimum et l'autre pour l'épaisseur maximum. Ceci permet d'utiliser la machine comme machine à étirer la pizza avec un double passage et, également, l'étirage de pizzas pour plaque de four ou de petites quantités de pâte feuilletée. Très efficace avec la pâte fraîche, elle garantit une feuille de pâte très fine et très régulière. Les commandes et les dispositifs de sécurité pour éviter les accidents ont été particulièrement soignés et ils sont parfaitement conformes aux normes en vigueur, quant aux opérations d'entretien, elles se limitent au nettoyage et au contrôle périodique.



Данная вертикальная тестораскаточная машина была сконструирована для раскатки теста в небольших помещениях, где очень ценится полезное пространство. Она обладает преимуществом, являясь очень компактной при работе и еще более компактной, находясь в нерабочем положении. Два стальных цилиндра, покрытых твердым хромом, с легко снимаемыми скребками, гарантируют идеальное раскатывание, а мощные детали механизма позволяют работать с крутым и плотным тестом. Открытие и закрытие щели между цилиндрами осуществляется с помощью легко управляемой рукоятки с использованием двух регуляторов для корректировки минимальной и максимальной толщины теста. Это означает, что машина также может быть использована для раскатки теста для пиццы (двойная раскатка), теста для выпечки на противне или небольшого количества слоеной сдобы. Машина идеальна для раскатки свежего теста, а использование инвертора для контроля скорости делает работу более простой и позволяет очень тонко и равномерно раскатывать тесто. Особое внимание было уделено противотравматическим системам, которые полностью соответствуют существующим стандартам. Необходимое техническое обслуживание сводится только к периодической чистке и контролю.



# Panificazione - Bakery

PLANETARIE  
MIXERS



**50 Aeromix**  
Impastatrici planetarie  
Planetary Mixers



**52 Powermix**  
Impastatrici planetarie automatiche a disimpegno totale  
Automatic Planetary Mixers with total disengagement



IMPASTATRICI  
INDUSTRIALI  
INDUSTRIAL MIXERS



**60 Silver Line**  
Impastatrici a spirale con vasca estraibile  
Spiral mixers with removable bowl



**64 Super Premium**  
Impastatrici a spirale con vasca estraibile  
Spiral mixers with removable bowl



**66 Gold Line**  
Impastatrici a spirale con scarico dal fondo  
Spiral mixers with bottom discharge

SOLLEVATORI  
LIFTERS



**72 Maciste-MacisteMax**  
Sollevatori per vasche estraibili  
Spiral mixer Lifters



**76 Hercules**  
Sollevatori per vasche estraibili  
Spiral mixer Lifters



**78 Sollevatori Planetarie**  
Sollevatori per vasche planetarie  
Planetary mixer Lifters

SPEZZATRICI  
DIVIDERS



**86 Spezzatrici Volumetriche**  
Spezzatrici volumetriche  
Volumetric Dividers



**88 Arrotondatrici Coniche**  
Arrotondatrici coniche  
Conical Rounders



**90 Spezzarrotondatrici**  
Spezzarrotondatrici  
Bun Dividers



IMPASTATRICI  
MIXERS



**54 Red Line**  
Impastatrici a spirale a vasca fissa  
Spiral Mixers with fixed bowl



**56 Green Line**  
Impastatrici a spirale a vasca fissa  
Spiral Mixers with fixed bowl



**58 Autosvuotanti**  
Impastatrici a spirale autosvuotanti  
Overturnable Spiral Mixers

IMPASTATRICI  
MIXERS



**68 A bracci tuffanti**  
Impastatrici a bracci tuffanti  
Twin arms mixers



**70 A forcella**  
Impastatrici a Forcella  
Fork mixers

SOLLEVATORI  
LIFTERS



**80 Ribaltatori**  
Tipper lifters

TRAMOGGE  
FEEDING HOPPERS



**82 Tramogge**  
Tramogge di alimentazione  
Feeding Hoppers

SPEZZATRICI  
DIVIDERS



**92 Esagonali/Quadre**  
Spezzatrici esagonali e quadre  
Hexagonal and Square Dividers

FORMATRICI  
MOULDERS



**98 Formatrici a 3 cilindri**  
Formatrici per Baguette a 3 cilindri  
3 cylinders Baguette moulders



**100 Formatrici a 2 cilindri**  
Formatrici per pane avvolto  
Long loaf moulders





## Panificazione Bakery



### “Aeromix” Impastatrici planetarie Planetary Mixers



Modello Model	KW	Peso Weight (Kg)	Alimentazione Voltage	Vasca Bowl (Lt.)	Diametro Vasca Bowl dimension (mm)	Dimensioni Dimension (mm)
Aeromix 7,5	0,25	40	220/1/50	8	230x210	365x400x615
Aeromix 10	0,50	58	400/3/50	10	250x230	560x600x775
Aeromix 20	0,90	112	400/3/50	20	315x290	605x725x840
Aeromix 20H	0,90	132	400/3/50	20	315x290	605x725x1180
Aeromix 30	1,10	134	400/3/50	30	350x365	605x735x1180
Aeromix 40	1,50	170	400/3/50	40	400x370	700x920x1355
Aeromix 60	2,20	290	400/3/50	60	450x370	800x1000x1750
Aeromix 80	4,00	415	400/3/50	80	480x506	800x1015x1954
Aeromix 100	4,00	435	400/3/50	100	510x600	800x1029x1954
Aeromix 120	4,00	580	400/3/50	120	550x600	980x1115x2045
Aeromix 160	5,50	595	400/3/50	160	600x600	980x1255x2045

#### CARATTERISTICHE TECNICHE GENERALI GENERAL TECHNICAL CHARACTERISTICS

- Elevata coppia motrice a bassi regimi
- Discesa e salita vasca motorizzata (40÷160 lt)
- Disimpegno totale utensile (60÷160 lt)
- Timer, contagiri e termostato con sonda-cuore (60÷160 lt)
- Dotazione standard: spirale, pala, frusta 2° e 3° utensile di miscelazione
- Vasca carrellata (60÷160 lt)
- Pannello di comando programmabile 5 vel + pausa (60÷160 lt)
- Griglia inox asportabile
- Normative CE
- Certificazione GOST
- High torque at low speeds
- Stainless steel bowl
- Motorized bowl lifting (40÷160 lt)
- Total release of the tool (60÷160 lt)
- Timer, revolution counter and thermometer with heart probe (60÷160 lt)
- Standard equipment: spiral, blade, whisk, 2<sup>nd</sup> and 3<sup>rd</sup> mixing tool
- Bowl on wheels (60÷160 lt)
- Programmable control panel with 5 speeds + pause (60÷160)
- Removable stainless steel grid
- CE rules
- GOST certification

#### OPTIONALS

- Tensioni speciali
- Insufflazione aria nella vasca
- Versione inox
- Illuminazione Vasca
- Tappo scarico vasca
- Sistema nebulizzazione acqua
- Pannello di comando con PLC
- Special tensions
- Air pressure incoming system
- Stainless steel version
- Bowl lighting
- Drain bowl cap
- Water nebulisation system
- PLC control panel



Aeromix è il nome di questa linea di planetarie dalle caratteristiche eccezionali. Sono impeccabili nei rapporti di velocità, danno i migliori risultati qualitativi nelle mescolazioni tipiche per pasticceria e gastronomia, con l'uso delle fruste con i prodotti montati e con le pale nelle emulsioni. Ciò che le rende uniche è l'uso combinato di due utensili speciali nella produzione degli impasti: una spirale molto particolare che interagisce con un secondo utensile rotante che ha la funzione di contrastare l'azione della spirale ottenendo così una doppia raffinazione dell'impasto oltre ad aerarlo maggiormente per effetto della continua ripartizione che l'impasto subisce durante la lavorazione. Tale invenzione, coperta da un brevetto mondiale unico nel suo genere, garantisce un risultato dell'impasto nettamente migliore, soprattutto nella formazione della maglia glutinica. La planetaria diventa quindi a tutti gli effetti una impastatrice di ottime prestazioni poiché l'utensile di contrasto, interagendo con la spirale, fornisce una migliore ripartizione della pasta, razionalizzando quindi la funzione della spirale e scaricando le forze di spinta sulla vasca, consentendo quindi un notevole incremento della capacità di impasto della macchina.



Aeromix ist der Name dieser Planetenrührmaschine mit herausragenden Eigenschaften. Die optimalen Geschwindigkeitsverhältnisse erlauben qualitativ höchste Resultate bei Emulsionen, Mischungen und Teigmassen im Konditorei- und Gastronomiebereich. Was diese Linie einzigartig macht, ist die Kombination von zwei speziellen Werkzeugen für die Produktion von Teigen: eine spezielle Spirale interagiert mit einem zweiten umlaufenden Werkzeug, das der Bewegung der Spirale entgegenwirkt. So wird der Teig dank seiner unaufhörlichen Teilung besonders fein und luftig. Diese mit einem Patent geschützte Erfindung ermöglicht die Herstellung eines, im Vergleich zu herkömmlichen Geräeten, viel besseren Teiges, besonders im Hinblick auf die Bildung von Gluten. Die Planetenrührmaschine AEROMIX ist in jeder Hinsicht ein ausgezeichneter Kneiter da das zweite, gegenläufige Werkzeug, in Wechselwirkung mit der Spirale, eine bessere Mischung und Sauerstoffaufnahme des Teiges bewirkt. Auf diese Weise wird die Mischkapazität der Spirale optimiert. Die Kombination der zwei Werkzeugen reduziert zudem erheblich die Schwingungen und Druckkräfte auf den Kessel. Daher kann eine deutlich höhere Teigkapazität erreicht werden.



Aeromix is the name of this line of planetary mixers with exceptional features. With their outstanding speed ratio, they offer the best results in terms of quality when used with whisks for whipped products and with blades for emulsions, typical mixtures for pastry and gastronomy. What makes these machines unique is the combined use of two tools, special in the production of dough: a very particular spiral that interacts with a second rotating tool. This tool has the task to contrast the action of the spiral, getting a double refining and a bigger airing of dough, thanks to its continuous division of the dough during its preparation. Such an invention, covered by a worldwide patent unique in its sort, guarantees a much better dough result, particularly in making the gluten net. Therefore "the planetary" becomes at all intents and purposes a mixer for excellent performances. As a matter of fact the counter tool, interacting with the spiral, makes a very good division of dough, rationalizing the spiral task and relieving the push forces on the bowl. In this way the dough capacity of the machine is remarkably increased.



Aeromix es el nombre de estas batidoras de características excepcionales. Impecables en relaciones de velocidad, éstas brindan los mejores resultados de calidad en las emulsiones, mezclas y amasados para pastelería y gastronomía. Lo que hace únicas a estas máquinas es el uso combinado de dos útiles especiales en la producción de la masa: una espiral muy particular que interactúa con un segundo útil rotativo que tiene la función de oponerse a la acción de la espiral, obteniendo así un doble refinado y un mayor aireamiento de la masa gracias a la continua división de ésta durante su preparación. Tal invención, única en su género y cubierta por una patente mundial, garantiza un resultado en el amasado notablemente mejor, sobretodo en la formación de la estructura glutínica. La batidora planetaria se convierte entonces a todos los efectos en una amasadora, porque el útil de contraste, interactuando con la espiral, garantiza una mejor mezcla y oxigenación de la masa, aprovechando al máximo la capacidad de amasado propia de la espiral. La acción combinada de los dos útiles reduce notablemente las vibraciones y el empuje sobre la artesa y sobre el eje de transmisión; resultando que para el mismo volumen de artesa se incrementa la capacidad máxima de amasado de la batidora."



Aeromix est le nom de cette ligne des batteurs mélangeur avec caractéristiques exceptionnelles. Impeccable dans les rapports de vitesse, ils donnent les meilleurs résultats de qualité, avec l'utilisation de fouets sur les produits fouettés et avec les palettes pour les émulsions typique de la boulangerie. Ce qui les rend unique est l'utilisation combinée de deux outils spéciaux dans la production des mélanges: une spirale très particulière qui interagit avec un second outil rotatif qui a la fonction de contrer l'action de la spirale en obtenant ainsi un raffinage double de la pâte et une aération plus importante par la distribution continue que le mélange subit pendant le traitement. Cette invention, qui est couverte par un brevet mondiale unique en son genre, fournit un résultat significativement meilleur du mélange, en particulier dans la formation du gluten. Le Batteur devient ainsi effectivement un pétrin d'excellente performance, parce que l'outil de contraste, coopérant avec la spirale, fournit une meilleure répartition de la pâte à l'intérieur de la cuve, en rationalisant la fonction de la spirale et la distribution des forces de poussée sur la paroi de la cuve, permettant ainsi une augmentation considérable de la capacité de mélange de la machine.



Aeromix – это тип планетарных машин, обладающих удивительными характеристиками. Безукоризненные по соотношению скоростей, они дают наилучшие качественные результаты при производстве эмульсий, смесей и теста для кондитерских и кулинарных изделий. То что делает эти машины незаменимыми это комбинирование 2х специальных инструментов для приготовления смесей. Первая это особая спираль которая, взаимодействует со вторым вращающимся инструментом имеющим противодействующую движению спирали функцию. С помощью постоянного дробления смеси во время обработки, которое насыщает его воздухом, тесто получается мягким и пушистым. Это изобретение, имеющее единственный в своем роде патент, гарантирует наилучшее качество теста особенно в образовании клейковины. Планетарная машина таким образом становится великолепным тестомесом, благодаря контрастирующему инструменту, который входя в контакт со спиралью, позволяет лучший замес теста максимально используя производственную мощность спирали. Комбинирующее действие этих 2х инструментов значительно уменьшает вибрацию и интенсивность толчка на дежу и на передаточный вал. Таким образом, в зависимости от объема дежи, увеличивается максимальная способность замеса планетарной машины.





## Panificazione Bakery



### “Powermix”

Impastatrici planetarie automatiche a disimpegno totale  
Automatic Planetary Mixers with total disengagement

### POWERMIX



Modello Model	KW	Peso Weight (Kg)	Alimentazione Voltage	Vasca Bowl (Lt.)	Diametro Vasca Bowl dimension (mm)	Dimensioni Dimension (mm)
Powermix 60DT	2,20	290	400/3/50	60	450X430	800X1000X1750
Powermix 70DT	3,00	300	400/3/50	75	480X506	800X1000X1750
Powermix 80	4,00	410	400/3/50	80	510X510	800x1015x1954
Powermix 100	4,00	430	400/3/50	100	510X600	800x1029x1954
Powermix 120	4,00	595	400/3/50	120	550X600	980x1115x2045
Powermix 160	5,50	610	400/3/50	160	600X600	980x1255x2045

### ACCESSORI ACCESSORIES

Modello  
Model

Sollevatore/Bowl lifters DT

Vasca extra/Extra bowl DT 60

Vasca extra/Extra bowl DT 80

Vasca extra/Extra bowl PE 100

Vasca extra/Extra bowl PE 120

Vasca extra/Extra bowl PE 160

Frusta/Whisk 100

Frusta/Whisk 120

Frusta/Whisk 160

Pala/Blade 100

Pala/Blade 120

Pala/Blade 160

Raschiatore/Scrapers 60-70

Raschiatore/Scrapers 80-160

### CARATTERISTICHE TECNICHE GENERALI GENERAL TECHNICAL CHARACTERISTICS

- Variatore elettronico (inverter)
- 6 velocità + variazione continua
- Pannello comandi programmabile a tenuta stagna
- Struttura in lamiera d'acciaio di grosso spessore sovradimensionata
- Ingranaggi cementati, temperati, rettificati in bagno d'olio
- Timer, contagiri e termostato con sonda-cuore
- Salita e discesa motorizzata
- Dotazione standard 3 utensili
- Discesa vasca lunga per disimpegno totale dell'utensile
- Riparo antinfortunistico asportabile
- Normativa CE e certificazione GOST
- Electronic variator (Inverter)
- 6 speeds + continuous variation
- Programmable control panel with watertight seals
- Oversized structure in high thickness steel sheet
- Timer, revolution counter and thermometer with heart probe
- Motorized bowl lifting
- Turnable protection easily removable
- Long bowl stroke for the total tool disengagement
- Hardened, tempered and rectified gears in oil bath
- Standard equipment 3 tools
- Removable protection
- CE rules and GOST certification

### OPTIONALS

- Tensioni speciali
- Disponibili riduzione vasca e attrezzi
- Versione inox
- Pannello di comando con PLC
- Tappo scarico vasca
- Illuminazione Vasca
- Sistema nebulizzazione acqua
- Special tensions
- Smaller bowls and tools available
- Stainless steel version
- PLC control panel
- Drain bowl cap
- Bowl lightnig
- Water nebulisation system



PE è il nome di queste planetarie dalle caratteristiche eccezionali. Impeccabili nei rapporti di velocità, esse danno i migliori risultati qualitativi nelle emulsioni, mescolazioni ed impasti per pasticceria e gastronomia. Migliaia di esemplari costruiti sono la migliore garanzia dell' affidabilità e robustezza di queste macchine. Tutti i modelli garantiscono la discesa e la salita automatica della vasca con disimpegno totale dell' utensile. Sono equipaggiati con variatore elettronico e comodo pannello comandi programmabile. La grande riserva di potenza e la eccezionale robustezza le rendono adatte ad un uso altamente professionale. La griglia di protezione facilmente smontabile per il lavaggio, i dispositivi di sicurezza, le molte parti trattate al nichel chimico alimentare e le verniciature certificate hanno consentito a questa linea di macchine di ottenere l' approvazione dei più prestigiosi enti internazionali certificatori della qualità. Oltre alle dotazioni standard come vasca, pala, frusta e spirale, le macchine possono essere dotate di una numerosa serie di accessori come raschiatori, fruste speciali, carrelli porta vasca, protezioni trasparenti, riduttore con presa di forza laterale (solo per i modelli PE60 e PE80), macinacarne, tagliaverdure, vasche e utensili ridotti, bruciatori a gas. Il tutto consente di offrire al cliente un' ampia scelta per ottenere dalla macchina il massimo della efficienza e versatilità.



PE ist der Name dieses Planetenrührmaschinen mit herausragenden Eigenschaften. Die einwandfreien Geschwindigkeitsverhältnisse erlauben die qualitativ höchsten Resultate bei Emulsionen, Mischungen und Teigmassen im Konditorei- und Gastronomiebereich. Tausende bereits hergestellte Exemplare sind die beste Garantie für die Zuverlässigkeit und Robustheit dieser Maschinen. Alle Modelle garantieren den Aufstieg und Abstieg des Kessels automatisch mit der totalen Entbindung des Werkzeuges und sind mit einer bequemer programmierbarer Schalttafel ausgerüstet. Durch die große Kraftreserve und die hervorragende Robustheit ist die Maschine für professionelle Anwendungen auf hohem Niveau bestens geeignet. Das zur Reinigung leicht abzumontierende Schutzgitter, die Sicherheitsvorrichtungen, die vielen für die Lebensmittelproduktion chemisch mit Nickel behandelten Teile sowie die zertifizierten Lackierungen haben dazu geführt, dass diese Maschinenbaureihe die Abnahmeprüfungen der namhaftesten internationalen Qualitätsprüfeinrichtungen bestanden hat. Außer der Standardausrüstung wie Wanne, Mischfügel, Schneebeesen und Spirale, können die Maschinen auch mit vielen Zubehörteilen wie Schaber, besonderen Schneebeesen, Wannentransportvorrichtungen, transparenten Schutzvorrichtungen, Untersetzungsgetriebe mit seitlicher Befestigung (Nur für die Modelle PE60/PE80), Hackfl eischmühle, Gemüseschneider, kleineren Wannen und Mischwerkzeugen, Gasbrennern ausgestattet werden. All dies erlaubt es, dem Kunden eine weitreichende Auswahl anzubieten, welche höchste Effizienz und Versatilität garantiert.



PE is the name of this line of planetary mixers with exceptional features. With their outstanding speed ratio, they offer the best results in terms of quality when used for making emulsions, mixtures and dough for pastry-making and food preparations. The thousands of units we have produced testify to the reliable and long-lasting performance of these machines. All the models guarantee that the bowl goes up and down automatically with the total disengagement of the tool, they are equipped with an electronic variator and an easy-to-use programmable control panel. Thanks to their longlasting power supply and durable construction these machines stand up to rigorous professional use. The protection grid, which is easily detachable for cleaning, the safety devices, the fact that most parts of the machines are treated with nickel plating for food use and the certified paint finishes we use have earned this series the approval of the most prestigious international quality certifiers. In addition to the standard features like the bowl, the blade, the whip and the spiral, these machines can also be equipped with a number of extra accessories like scrapers, special whips, trolleys for bowls, transparent safety protection, reducers (just for the models PE60 PE80), meat mincers, vegetable slicers, reduction bowls and tools and gas burners. All these features offer our customers a wide range of choices, allowing them to obtain the maximum efficiency and versatility from our machines.



PE es el nombre de estas batidoras de características excepcionales. Impecables en las relaciones de velocidad, éstas brindan los mejores resultados de calidad en las emulsiones, mezclas y amasados para pastelería y gastronomía. Miles de ejemplares fabricados son la mejor garantía de la fiabilidad y robustez de estas máquinas. Todos modelos garantizan la bajada y la subida del perrol automáticamente con la total salida del utensilio. Están dotados de variador electrónico y de un práctico panel de mandos programable. La gran reserva de potencia y la excepcional robustez las hacen adecuadas para un uso altamente profesional. La rejilla de protección fácilmente desarmable para el lavado, los dispositivos de seguridad, las numerosas piezas tratadas con níquel químico alimentario y los barnizados certificados han permitido que esta línea de máquinas obtuviera la aprobación de los más prestigiosos entes internacionales de certificación de calidad. Además de las dotaciones estándar tales como el perrol, la pala, el batidor y la espiral, las máquinas pueden ser dotadas de una nutrida serie de accesorios como rascadores, batidores especiales, carritos porta cubetas, protecciones transparentes, reductor con toma de energía lateral (solo por los modelos PE60/PE80), picador de carne, corta verduras, perrol y utensilios reducidos, quemadores de gas. Todo esto nos permite brindar al cliente una amplia gama de posibilidades para obtener de la máquina la máxima eficiencia y versatilidad.



PE est le nom de ce batteur mélangeur aux caractéristiques exceptionnelles. Les rapports de vitesse sont impeccables et donnent les meilleurs résultats relatifs à la qualité des émulsions, des mélanges et des pétrissages pour les pâtisseries et les plats cuisinés. Les milliers d'exemplaires construits sont la meilleure garantie de la fiabilité et de la robustesse de ces machines. Tous les modèles ont la montée et la descente de cuve automatique avec le désengagement total de l'outil. Sont équipés de variateur électronique et de panneau de commande pratique et programmable. La grande réserve de puissance et l'exceptionnelle robustesse les rendent aptes à une utilisation hautement professionnelle. La grille de protection facilement démontable pour le nettoyage, les dispositifs de sécurité, les nombreuses parties traitées au nickel chimique alimentaire et les vernis certifiés ont permis à cette ligne de machines d'obtenir l'approbation des plus prestigieux organismes internationaux qui en certifient la qualité. En plus des équipements standards comme la cuve, la palette, le fouet et la spirale, les machines peuvent être équipées d'une série d'accessoires comme les racleurs, les fouets spéciaux, les chariots porte cuve, les protections transparentes, les réducteurs avec prise de force latérales (seulement pour les modèles PE60/PE80), les hacheviande, les coupe légumes, les cuves et les outils réduits, les brûleurs à gaz. Le tout permet d'offrir au client un grand choix afin d'obtenir de la machine le maximum de l'efficacité et de l'assortiment.



PE – это тип планетарных машин, обладающих удивительными характеристиками. Безукоризненные в отношении скорости, они дают лучшие качественные результаты с эмульсиями, смесями и тестом для кондитерских и кулинарных изделий. Тысячи созданных машин являются лучшей гарантией их надёжности и прочности. Все модели оснащены автоматическим механизмом подъёма и спуска дежи с полным высвобождением рабочего органа. Они укомплектованы электронным вариатором и простой в работе программируемой панелью управления. Благодаря большому запасу мощности и чрезвычайной прочности, эти машины пригодны для высоко профессионального использования. Защитная решётка, легко снимаемая для мытья, защитные устройства, многочисленные детали, покрытые никелем, пригодны для использования с пищевыми продуктами, а также сертифицированная краска, позволили данной линии машин получить сертификаты, подтверждающие качество, от наиболее престижных международных сертификационных органов. Дополнительно к стандартным принадлежностям, таким как дежа, лопатка, венчик и спираль, эти машины могут быть также укомплектованы некоторыми дополнительными принадлежностями, такими как скребок, специальные венчики, тележки для деж, прозрачные защитные устройства, редуктор понижающей передачи (только для моделей PE60 и PE80), мясорубки, овощерезки, дежи меньшего объёма, инструменты и газовые горелки. Всё это позволяет предложить заказчику широкий выбор для достижения максимальной эффективности и многоцелевого применения машины.





## Panificazione Bakery



### “Red Line”

Impastatrici a spirale a vasca fissa  
Spiral Mixers with fixed bowl



RED LINE  
FIXED BOWL  
SPIRAL MIXERS



Modello Model	KW	Peso Weight (Kg)	Alimentazione Voltage	Vasca Bowl (Lt.)	Dimensioni Dimension (mm)	Max farina Max flour (Kg)	Min acqua Min water (Lt.)
SILVER 50 trifase/3 phase	1,9/2,6	182	400/3/50	67	530X920X1140	30	17
SILVER 50 monofase/1 phase	1,9 2,6	182	220/1/50	67	530X920X1140	30	17
SILVER 60 trifase/3 phase	1,9/2,6	192	400/3/50	81	590X950X1140	35	21
SILVER 60 monofase/1 phase	1,9/2,6	192	220/1/50	81	590X950X1140	35	21
SILVER 60 PLUS	2,0/3,7	320	400/3/50	100	740X1140X1310	40	21
SILVER 80	2,0/3,7	330	400/3/50	130	740X1140X1310	50	30
SILVER 120	2,6/4,8	490	400/3/50	170	780X1370X1450	75	45
SILVER 160	3,7/7,75	690	400/3/50	230	910X1500X1600	100	60
SILVER 160 HD*	3,7/7,75	690	400/3/50	230	910X1500X1600	100	60
SILVER 200	5,9/10,3	750	400/3/50	290	910X1570X1600	125	75
SILVER 200 HD*	5,9/10,3	750	400/3/50	290	910X1570X1600	125	75
SILVER 280	6,5/11,0	830	400/3/50	420	1050X1670X1600	175	105
SILVER 280 HD*	6,5/11,0	830	400/3/50	420	1050X1670X1600	175	105

### CARATTERISTICHE TECNICHE GENERALI GENERAL TECHNICAL CHARACTERISTICS

- Due motori: uno per spirale a 2 velocità e uno per vasca con inversione
- Vasca/spirale/piantone in acciaio inox
- Tasto impulsi vasca
- Chiave di sicurezza per utilizzo manuale
- Protezione vasca secondo ultima normativa CE
- Comando elettromeccanico con 2 timers
- Macchina su ruote
- Normative CE
- Certificazione GOST e ETL
- Two motors: 1 for the 2 speeds spiral and 1 for the bowl with inversion
- Stainless steel bowl, spiral and shaft
- Bowl jogs button
- Security key for manual use
- Bowl protection according to the CE rules
- Electromechanical control panel with 2 timers
- Machine mounted on wheels
- CE rules
- GOST and ETL certification

### OPTIONALS

- Pannello comando elettronico a 2 timers programmabile
- Tensioni speciali
- Tappo vasca
- Pannello di comando con PLC
- Regolazione velocità vasca e/o spirale
- Versione inox
- Sonda temperatura
- Raschiatore e Contaltri
- Programmable electronic control panel with 2 timers
- Special tensions
- Drain bowl cap
- PLC control panel
- Bowl and spiral control speed
- Stainless steel version
- Temperature probe
- Scraper and Water dosing



Questa linea di impastatrici a spirale con vasca fissa si distingue per le seguenti caratteristiche:

- Costruzione solida e robusta
- Protezione vasca largamente coperta
- Due motori, uno per la spirale ed uno per la vasca
- Grande riserva di potenza
- Dimensioni d'ingombro contenute
- Manutenzione estremamente limitata
- Minima quantità d'acqua 50%

Le impastatrici della linea Silver vengono normalmente fornite con una apparecchiatura standard completa di pannello comandi elettromeccanico con due temporizzatori, a sinistra per la 1<sup>a</sup> velocità e a destra per la 2<sup>a</sup> velocità, per mezzo dei quali è possibile pre-impostare i tempi di lavorazione desiderati. Il selettore a chiave consente di operare in prima e in seconda manualmente senza il controllo dei tempi, ciò è utile in caso di guasto dei timers e non provoca il fermo macchina. Il selettore con il simbolo della vasca e le due frecce contrapposte, consente di invertire il senso di rotazione della sola vasca, per favorire la pre-miscelazione in prima velocità, quando questa si rende necessaria. Il pulsante di marcia espleta la sua funzione di inizio ciclo, mentre a fine impasto e a griglia sollevata consente di fare girare la vasca ad impulsi per favorire il prelievo della pasta. È possibile fornire a richiesta un pannello comandi elettronico con 2 timers digitali.



This line of fixed bowl spiral mixer is distinguished by the following features:

- A solid and sturdy construction
- Widely covered bowl protection
- Two motors, one for the spiral and one for the bowl
- Great power reserves
- Minimum overall dimensions
- Practically maintenance-free
- Minimum quantity of water 50%

The mixers of the Silver Line are regularly supplied with standard equipment complete with an electromechanical control panel with two timers. The left timer regulates the 1<sup>st</sup> speed and the right timer regulates the 2<sup>nd</sup> speed. The timers allow to adjust the desired working times. The key selector allows manual operation in first and second speeds without the control of the working times. This allows the machine to be operated even in case of malfunctions of the timers. The selector with the tank symbol and the two opposing arrows permits the inversion of the rotation direction of only the tank, to facilitate pre-mixing in 1<sup>st</sup> speed when necessary. The run button starts the cycle, while at the end of the mixing phase, when the grill is raised, operates as a jog control of the tank rotation, facilitating the removal of the mixture. Upon request, an electronic control panel can be supplied, featuring 2 digital timers.



Cette ligne de pétrins spirales à cuve fixe se distingue par les points suivants:

- Une construction solide et robuste
- Protection de la cuve largement couvrant
- Deux moteurs, un pour la cuve et un pour la spirale
- Grande réserve de puissance
- Dimensions externes réduites
- Presque sans maintenance
- Minimum quantité d'eau 50%

Les pétrins de la gamme Silver sont livrés en standard avec un tableau de commandes avec 2 minuteries. La minuterie gauche règle la première vitesse et la minuterie droite, la deuxième. Les minuteries permettent d'ajuster la durée voulue de pétrissage. Le sélecteur à clé permet un fonctionnement sans les minuteries. Ceci permet un fonctionnement même en cas d'avarie des minuteries. Le sélecteur montrant une cuve permet l'inversion de la rotation de la cuve pour faciliter le frassage en première vitesse si nécessaire. Le bouton marche démarre le cycle et en fin de cycle, lorsque la grille est relevée, fonctionne comme un bouton à impulsion faisant avancer la cuve pas à pas facilitant le retrait de la pâte. Sur demande, un panneau de commande électronique avec 2 minuteries digitales.



Die Linie der Spiralknetmaschinen mit fester Schüssel zeichnet sich durch folgende Eigenschaften aus:

- Solide und robuste Konstruktion
- Kesselschuetzung weit bedeckt
- Zwei Motoren, einer für die Spirale und einer für die Schüssel
- Große Leistungsreserve
- Geringer Raumbedarf
- Extrem geringer Wartungsaufwand
- Mindeste Quantitaet von Wasser 50%

Die Knetmaschinen der Silver-Linie werden gewöhnlich mit einem Standardgerät komplett mit elektromechanischer Steuertafel geliefert. Die Steuertafel ist mit zwei Zeitgebern ausgestattet, einem links für die 1. Geschwindigkeit und einem rechts für die 2. Geschwindigkeit, mit denen die gewünschten Bearbeitungszeiten eingestellt werden können. Der Schlüsselwählschalter ermöglicht, in der ersten und in der zweiten Geschwindigkeit manuell ohne die Zeitsteuerung zu arbeiten, was bei einer Störung der Timer von Vorteil ist und keinen Maschinenstillstand zur Folge hat. Der Wählschalter mit dem Schüsselsymbol und den beiden entgegengesetzten Pfeilen ermöglicht, allein die Drehrichtung der Schüssel zu wechseln, um bei Bedarf die Vormischung in der ersten Geschwindigkeit zu begünstigen. Der Startschalter dient dem Zyklusstart und ermöglicht zudem nach Abschluss des Knetvorgangs und bei angehobenem Gitter die Schüssel impulsartig zu drehen, um das Herausnehmen des Teigs zu erleichtern. Auf Anfrage kann eine elektronische Steuertafel mit 2 Digitaltimern geliefert werden.



Esta línea de amasadoras de espiral con cuba fija tiene las siguientes características:

- Una construcción muy robusta con pintura de alta calidad
- Amplia protección del perro
- Dos motores, uno para el útil y otro para la cuba
- Grande reserva de potencia
- Dimensiones al suelo muy reducidas
- Prácticamente sin mantenimiento
- Mínima cantidad de agua 50%

Las máquinas amasadoras de la línea Silver normalmente se suministran con un equipamiento estándar provisto de panel de mandos electromecánico con dos temporizadores, el de la izquierda para la 1<sup>a</sup> velocidad y el de la derecha para la 2<sup>a</sup> velocidad, por medio de los cuales es posible reprogramar los tiempos de elaboración deseados. El selector de llave permite su funcionamiento en primera y segunda velocidad manualmente sin el control de tiempos, esto es útil en caso de avería de los temporizadores y no provoca la parada del aparato. El selector con el símbolo del recipiente y las dos flechas contrapuestas, permite invertir el sentido de rotación sólo del recipiente, para facilitar el premezclado con la primera velocidad, cuando fuera necesario. El pulsador de marcha cumple su función de inicio de ciclo, mientras que al final del amasado y con la rejilla levantada permite hacer girar el recipiente por impulsos para facilitar la recogida de la masa. Es posible suministrar bajo pedido un panel de mandos electrónico con 2 temporizadores digitales.



Эта серия спиральных тестомесильных машин с фиксированной дежкой имеет следующие характеристики:

- прочная конструкция;
- большая защитная крышка;
- два двигателя (для спирали и дежи);
- большой резерв мощности;
- небольшие габариты;
- незначительное техобслуживание;
- минимальное количество воды: 50%.

Тестомесильные машины линии "Silver" обычно поставляют в стандартной комплектации, включая электромеханическую панель с двумя таймерами: слева – для 1-й скорости и справа – для 2-й скорости. Таймеры позволяют установить необходимое время обработки. Переключатель с ключом позволяет работать вручную на 1-й и 2-й скоростях без контроля времени. Это полезно в случае поломки таймеров. Рукоятка с символом дежи и двумя встречными стрелками позволяет менять направление вращения только дежи для облегчения предварительного перемешивания на 1-й скорости. Кнопка запуска включает цикл, а также в конце замеса включает встряхивание дежи для облегчения выгрузки теста после поднятия решетки. По заказу возможна поставка электронной панели с двумя цифровыми таймерами.





## Panificazione Bakery



### “Green Line”

Impastatrici a spirale a vasca fissa  
Spiral Mixers with fixed bowl



Modello Model	KW	Peso Weight (Kg)	Alimentazione Voltage	Vasca Bowl (Lt.)	Dimensioni Dimension (mm)	Max farina Max flour (Kg)	Min acqua Min water (Lt.)
GREENLINE 50 trifase/3 phase	1,9 / 2,6	182	400/3/50	67	530X920X1140	30	17
GREENLINE 50 monofase/1 phase	1,9 / 2,6	182	220/1/50	67	530X920X1140	30	17
GREENLINE 60 trifase/3 phase	1,9 / 2,6	192	400/3/50	81	590X950X1140	35	21
GREENLINE 60 monofase/1 phase	1,9 / 2,6	192	220/1/50	81	590X950X1140	35	21
GREENLINE 80	2,0 / 3,7	330	400/3/50	130	710X1140X1310	50	30
GREENLINE 120	2,6 / 4,8	490	400/3/50	170	780X1370X1450	75	45

#### CARATTERISTICHE TECNICHE GENERALI GENERAL TECHNICAL CHARACTERISTICS

- Grande risparmio energetico sui cicli di lavoro (25% ca)
- Un solo motore a doppia velocità con inversione
- Vasca, spirale, piantone in acciaio inox
- Chiave di sicurezza per utilizzo manuale
- Comando con timers digitali
- Macchina su ruote
- Normative CE
- Certificazione ETL e GOST
- Energy saving 25% per working cycle
- Just one motor with double speed and inversion
- stainless steel bowl, spiral and shaft
- Security key for manual use
- Control panel with digital timers
- Machine mounted on wheels
- CE rules
- ETL and GOST certification

#### OPTIONALS

- Tensioni speciali
- Tappo vasca
- Pannello di comando con PLC
- Versione inox
- Sonda temperatura
- Raschiatore
- Contalitri
- Special tension
- Drain bowl cap
- PLC control panel
- Stainless steel version
- Temperature probe
- Scraper
- Water dosing



Questa linea di impastatrici a spirale con vasca fissa GREEN LINE si distingue per le seguenti caratteristiche:

- Risparmio energetico per ogni ciclo di lavorazione del 25% c.a.
- Un solo motore per spirale e vasca.
- Doppia velocità più inversione in 1<sup>a</sup> velocità
- Costruzione solida e robusta con carpenteria d'acciaio di grosso spessore
- Protezione vasca secondo le ultime normative di sicurezza
- Grande riserva di potenza
- Dimensioni di ingombro contenute
- Capacità di eseguire impasti perfetti sia con piccole quantità che con le quantità massime consentite
- Grande affidabilità
- Meccanica di grande robustezza, facilmente ispezionabile
- Manutenzione estremamente limitata
- Minima quantità d'acqua 50%

Le impastatrici della Linea GREEN LINE vengono fornite con un'apparecchiatura standard completa di pannello comandi con temporizzatori digitali per la 1<sup>a</sup> e per la 2<sup>a</sup> velocità, con possibilità di invertire il senso di rotazione della vasca solo in 1<sup>a</sup> velocità. Un selettore a chiave di emergenza consente di operare manualmente in entrambe le velocità di marcia, con un controllo diretto dei tempi di lavoro desiderati, utile in caso di guasti improvvisi dei timer.



This line of fixed bowl spiral mixers GREEN LINE is characterized by the following main features:

- 25% energy saving at each manufacturing cycle
- 1 motor for both spiral and bowl
- Double speed, with possibility of inversion in 1<sup>st</sup> speed
- Solid and sturdy construction with thick steel frame
- Bowl protection according to the latest safety standards
- Great power reserves
- Compact design
- The ability to knead both small and large quantities of dough perfectly
- High reliability
- Solid mechanical design, easy to be inspected
- Practically maintenance-free
- Minimum quantity of water 50%

The mixers of the GREEN LINE are normally supplied with standard equipment including a control panel with two digital timers for 1<sup>st</sup> e 2<sup>nd</sup> speed and the possibility of the bowl inversion only in 1<sup>st</sup> speed. An emergency key selector allows manual operation excluding time control at both speeds. This is useful in case of timers shortcomings, for avoiding the standstill of the machine.



Cette ligne de pétrins à spirale avec cuve fixe GREEN LINE se distingue pour les caractéristiques suivantes:

- Economie d'énergie pour chaque cycle d'usinage de 25% environ
- Un seul moteur par spirale et cuve
- Double vitesse plus inversion en 1<sup>a</sup> vitesse
- Fabrication solide et robuste avec charpenterie en acier de grosse épaisseur
- Protection de la cuve selon les dernières réglementations de sécurité
- Grosse réserve de puissance
- Dimensions d'encombrement réduites
- Capacité d'effectuer des mélanges parfaits aussi bien avec des petites quantités qu'avec les quantités maximum autorisées
- Grande fiabilité
- Mécanique d'une grande solidité, facilement contrôlable
- Entretien extrêmement limité
- Hydratation de la pâte supérieur au 50%

Les pétrins de la Ligne GREEN LINE sont fournis avec un appareil standard équipé d'un panneau de commandes avec des temporisateurs digitales pour la 1<sup>a</sup> et la 2<sup>a</sup> vitesse, avec la possibilité d'inverser le sens de rotation de la cuve seulement avec la 1<sup>a</sup> vitesse. Un sélecteur à clé d'urgence permet d'opérer manuellement avec les deux vitesses de marche, avec un contrôle direct des temps de travail souhaités. Ceci est utile en cas de pannes improvisées des minuteurs, afin d'éviter l'arrêt total de la machine.



Die Linie der mit fester Schüssel Spiralenknetmaschinen GREEN LINE zeichnet sich durch folgende Eigenschaften aus:

- 25% Energiesparen während jedes Arbeitsgangs
- Einen einzigen Motor für die Spirale und für die Schüssel
- Doppelgeschwindigkeit mit der Möglichkeit, die Drehrichtung der Schüssel bei 1er Geschwindigkeit zu wechseln
- Starke und feste Konstruktion aus dickem rostfreierem Stahl
- Schüsselschutz nach den neuesten Sicherheitsnormen
- Große Leistungsreserve
- Geringen Raumbedarf
- Die Möglichkeit, einen perfekten Teig sowohl in kleinen Mengen als auch in der höchst zulässigen Menge zu bereiten
- Starke und einfach kontrollierbaren Maschinenbau
- Extrem geringen Wartungsaufwand
- Mindeste Quantität von Wasser 50%

Die Knetmaschinen der GREEN-Linie werden gewöhnlich mit einem mit Steuertafel ausgestatteten Standardgerät geliefert. Die Steuertafel ist mit zwei digitalen Zeitgebern ausgestattet, einem für die 1. Geschwindigkeit und einem für die 2. Geschwindigkeit mit der Möglichkeit, die Drehrichtung der Schüssel nur in 1. Geschwindigkeit zu wechseln. Der Schlüsselwählschalter ermöglicht, in der ersten und in der zweiten Geschwindigkeit manuell ohne die Zeitsteuerung zu arbeiten, was bei einer Störung des Timers von Vorteil ist und keinen Maschinenstillstand zur Folge hat.



Esta línea de amasadoras de espiral con cuba fija GREEN LINE tiene las siguientes características:

- Ahorro energético por cada ciclo de trabajo acerca del 25%
- Un solo motor por espiral y cuba
- Doble velocidad y inversión en la 1<sup>a</sup> velocidad
- Construcción sólida y robusta en carpentería de acero con gran espesor
- Protección de la cuba según las últimas normas de seguridad
- Grande reserva de potencia
- Dimensiones contenidas
- Posibilidad de amasar pequeñas o grandes cantidades de masas
- Mecánica robusta y de fácil inspección
- Prácticamente sin mantenimiento
- Mínima cantidad de agua 50%

Las amasadoras de la línea GREEN LINE normalmente se suministran con un equipamiento estándar provisto de panel de mandos con dos temporizadores digitales, para la 1<sup>a</sup> velocidad y la 2<sup>a</sup> velocidad, con posibilidad de invertir el sentido de roteación de la cuba solo en 1<sup>a</sup> velocidad. Un selector de llave de emergencia permite su funcionamiento en primera y segunda velocidad manualmente con un control de tiempo directo. Esto es útil en caso de avería de los temporizadores porque no provoca la parada del aparato.



Данная серия спиральных тестомесильных машин с фиксированной дежой «ЗЕЛЕНАЯ ЛИНИЯ» отличается следующими характеристиками:

- 25%-ая экономия энергии при каждом производственном цикле
- наличие одного двигателя для спирального рабочего органа и для дежи/емкости
- две рабочие скорости с возможностью обратного вращения на первой скорости
- прочная и надежная конструкция с крепкой рамой из нержавеющей стали
- наличие защитной решетки для дежи в соответствии с действующими стандартами по безопасности
- большая мощность реверса
- небольшие габариты
- превосходное качество замешиваемого теста, как небольшого, так и большого объема
- механическая конструкция, позволяющая легко проводить инспекционный осмотр
- ограниченная необходимость в техническом обслуживании
- Минимальное количество воды: 50%

Тестомесильные машины ЗЕЛеной ЛИНИИ обычно поставляются в комплекте со стандартной аппаратурой, включая панель управления с двумя цифровыми таймерами для первой и второй скорости, обеспечивающую обратное вращение дежи только на первой скорости. Вспомогательный переключатель позволяет работать на первой и второй скоростях в ручном режиме без контроля времени. Эта функция особенно полезна в случае поломки таймеров и предотвращает простой машины.





## Panificazione Bakery



### “Autosvuotanti”

Impastatrici a spirale autosvuotanti  
Overturnable Spiral Mixers



Modello Model	Sollevatore Lifter (Kw)	Impastatrice Mixer (Kw)	Peso Weight (Kg)	Alimentazione Voltage	Vasca Bowl (Lt.)	Dimensioni Dimension (mm)
SAU B 80	2,20	2,0 / 3,7	1280	400/3/50	130	2300X1360X2150÷2500
SAU T 80	2,20	2,0 / 3,7	1580	400/3/50	130	2300X1360X2150÷3200
SAU B 120	2,20	2,6 / 4,8	1300	400/3/50	170	2300X1400X2150÷2500
SAU T 120	2,20	2,6 / 4,8	1600	400/3/50	170	2300X1400X2150÷3200
SAU B 160	2,20	3,7 / 7,75	1600	400/3/50	230	2300X1440X2150÷2600
SAU B 160 HD*	2,20	3,7 / 7,75	1600	400/3/50	230	2300X1440X2150÷2600
SAU T 160	2,20	3,7 / 7,75	1900	400/3/50	230	2300X1440X2150÷3300
SAU T 160 HD*	2,20	3,7 / 7,75	1900	400/3/50	230	2300X1440X2150÷3300
SAU B 200	2,20	5,9 / 10,3	1650	400/3/50	290	2300X1470X2150÷2600
SAU B 200 HD*	2,20	5,9 / 10,3	1650	400/3/50	290	2300X1470X2150÷2600
SAU T 200	2,20	5,9 / 10,3	1950	400/3/50	290	2300X1470X2150÷3300
SAU T 200 HD*	2,20	5,9 / 10,3	1950	400/3/50	290	2300X1470X2150÷3300
SAU B 280	2,20	6,5 / 11,0	1700	400/3/50	420	2300X1520X2150÷2700
SAU B 280 HD*	2,20	6,5 / 11,0	1700	400/3/50	420	2300X1520X2150÷2700
SAU T 280	2,20	6,5 / 11,0	2000	400/3/50	420	2300X1520X2150÷3400
SAU T 280 HD*	2,20	6,5 / 11,0	2000	400/3/50	420	2300X1520X2150÷3400

## CARATTERISTICHE TECNICHE GENERALI GENERAL TECHNICAL CHARACTERISTICS

- Impastatrice autosvuotante composta da impastatrice Silver e sollevatore a vite
- Sistema di sicurezza anticaduta
- Costruzione solida e robusta con carpenteria di grosso spessore
- Possibilità di scarico dx o sx su banco o tramoggia
- Comando di inversione della vasca
- Normative CE
- Certificazione ETL e GOST
- Overturnable mixer made of Silver spiral mixer and screw system lifter
- Fall-arrest system
- A solid and sturdy structure in high thickness steel sheet
- Right/left Discharging side table/hopper high
- Bowl inversion button
- CE rules
- ETL and GOST certification

## OPTIONALS

- Pannello comando elettronico a 2 timers programmabile
- Tensioni speciali
- Pannello di comando con PLC
- Regolazione velocità vasca e/o spirale
- Versione inox
- Sonda temperatura
- Raschiatore
- Programmable electronic control panel with 2 timers
- Special tension
- PLC control panel
- Bowl and spiral control speed
- Stainless steel version
- Temperature probe
- Scraper



La linea di impastatrici a spirale autosvuotanti si compone dei seguenti modelli: 120 - 160 - 200 - 280 kg d'impasto. Queste impastatrici consentono di svuotare l'impasto dalla vasca direttamente su tavolo o su spezzatrice a seconda delle necessità. Realizzati per adattarsi alle esigenze specifiche dei locali, questi modelli costituiscono una soluzione vantaggiosa, con notevole riduzione dei tempi di produzione e dell'impiego di manodopera. Le impastatrici della linea SAU, grazie alla solida e robusta struttura, possono far fronte a cicli di lavoro intensi e richiedono poca manutenzione.



Unsere Linie von selbstausleerenden Spiralknetmaschinen besteht aus folgenden Modellen: für 120 – 160 und 200 - 280 kg. Teig. Diese Knetmaschinen erlauben die Ausladung des Teigs vom Becken direkt auf den Tisch oder in die Teilmaschine, je nach Bedarf. Nach den spezifischen Raumerfordernissen entwickelt, stellen diese Modelle eine günstige Lösung dar, die die Produktionszeiten und das verwendete Personal reduziert. Die Knetmaschinen der Linie SAU können, dank ihrer stabilen und soliden Struktur, schwere Arbeitszyklen aushalten und verlangen wenig Wartung.



The SAU line of overturnable mixers is available in models of 120 - 160 - 200 - 280 kg of dough. These mixers enable to empty automatically the dough from the bowl onto a table or in a divider. Designed to suit to a specific configuration, these models offer an efficient solution to reduce the need of man labour during dough processing. Based on a sturdy and reliable structure, the SAU models can intensively be used in operation and require very little maintenance works.



La línea de amasadoras de espiral autovaciantes se compone de los siguientes modelos: 120 – 160 – 200 - 280 kg. de amasado. Estas amasadoras permiten vaciar el amasado de la cuba directamente sobre la mesa o en divisora según las necesidades. Realizados para adaptarse a las exigencias específicas de los locales, estos modelos constituyen una solución ventajosa, con notable reducción de los tiempos de producción y del empleo de mano de obra. Las amasadoras de la línea SAU, gracias a la sólida y robusta estructura, pueden hacer frente a ciclos de trabajo intensos y requieren poco mantenimiento.



La ligne des pétrins à spirale auto-vidants est composée par les modèles suivants: 120 - 160 - 200 - 280 Kg. de pâte. Ces pétrins permettent de vider la pâte de la cuve directement sur la table ou sur les diviseuses selon les nécessités du moment. Réalisés pour pouvoir s'adapter aux exigences spécifiques des locaux, ces modèles constituent une solution très avantageuse avec des réductions des temps de production et de l'emploi de la main d'oeuvre. Les pétrins de la ligne SAU, grâce à leur structure solide et robuste, peuvent facilement affronter des cycles de travail intenses et ils n'ont pas besoin de beaucoup d'entretien.



Машины тестомесильные саморазгружающиеся серии SAU представлены моделями для массы теста на 120 - 160 - 200 - 280 кг. Эти тестомесильные машины способны выгружать тесто в автоматическом режиме из дежи на стол или в делитель. Сконструированные для работы со специфическими формами, эти модели являются экономичным решением замены ручного труда для замеса теста. Имеющие в основании прочную и надежную конструкцию, модели SAU могут быть интенсивно использованы в процессе производства и потребуют незначительного технического обслуживания.



## Panificazione Bakery



### “Silver Line”

Impastatrice a spirale con vasca estraibile  
Spiral mixers with removable bowl



Modello Model	Impastatrice Mixer (Kw)	Peso Weight (Kg)	Alimentazione Voltage	Vasca Bowl (Lt.)	Dimensioni Dimension (mm)
SILVER VE 80	4.0 / 8.0	676	400/3/50	130	1100x1450x1700
SILVER VE 120	4.0 / 8.0	690	400/3/50	170	1100x1570x1750
SILVER VE 160	6.0 / 12.0	980	400/3/50	230	1250x1850x1900
SILVER VE 160 HD*	6.0 / 12.0	980	400/3/50	230	1250x1850x1900
SILVER VE 200	6.0 / 12.0	1.015	400/3/50	290	1250x1850x1900
SILVER VE 200 HD*	6.0 / 12.0	1.015	400/3/50	290	1250x1850x1900
SILVER VE 250	7.0 / 15.0	1.027	400/3/50	350	1350x2000x1950
SILVER VE 250 HD*	7.0 / 15.0	1.027	400/3/50	350	1350x2000x1950
SILVER VE 300	7.0 / 15.0	1.038	400/3/50	400	1350x2000x1950
SILVER VE 300 HD*	7.0 / 15.0	1.038	400/3/50	400	1350x2000x1950

### ACCESSORI - ACCESSORIES

Modello Model	Peso Weight (Kg)	Vasca Bowl (Lt.)	Dimensioni Dimension (mm)
Vasca extra/Extra bowl CVE80	133	130	680X830X870
Vasca extra/Extra bowl CVE120	140	170	750X830X950
Vasca extra/Extra bowl CVE160	220	230	885X830X980
Vasca extra/Extra bowl CVE200	230	290	910X830X1040
Vasca extra/Extra bowl CVE250	265	350	1055X830X1190
Vasca extra/Extra bowl CVE300	280	400	1055X830X1190

\* HD: Heavy Duty Macchine adatte a lavoro intensivo poichè dotate di trasmissione a doppio invio  
Heavy Duty machines with double transmission



## CARATTERISTICHE TECNICHE GENERALI GENERAL TECHNICAL CHARACTERISTICS

- Vasca, spirale, piantone in acciaio inox
  - Due motori: uno per spirale a 2 velocità e uno per vasca con inversione
  - Tasto impulsi vasca
  - Comando elettromeccanico con 2 timers
  - Aggancio vasca elettromagnetico
  - Piedini regolabili in acciaio inox
  - Apparecchiatura elettrica in box pressurizzato
  - Apertura/chiusura testa con sistema idraulico
  - Barra di protezione antinfortunistica
  - Normative CE
  - Certificazione GOST e ETL
- 
- Bowl, spiral, shaft in stainless steel
  - Two motors: 1 for the 2 speeds spiral and 1 for the bowl with inversion
  - Bowl jogs button
  - Electromechanical control panel with 2 timers
  - Electromagnetic hook for bowl
  - Stainless steel adjustable feet
  - Pressurized electrical board
  - Mixer head driven by hydraulic system
  - Safety protection bar
  - CE rules
  - GOST and ETL certification

## OPTIONALS

- Utensili speciali
  - Tensioni speciali
  - Potenze maggiorate
  - Pannello di comando con PLC
  - Regolazione velocità vasca e/o spirale
  - Versione inox
  - Tappo vasca
  - Contalitri
  - Sonda temperatura
  - Raschiatore
- 
- Special tools
  - Special tensions
  - Higher power versions
  - PLC control panel
  - Bowl and spiral control speed
  - Drain bowl cap
  - Water dosing
  - Stainless steel version
  - Temperature probe
  - Scraper





## Panificazione Bakery

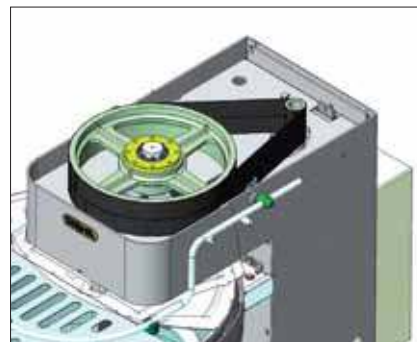

Trasmissione standard  
Standard transmission

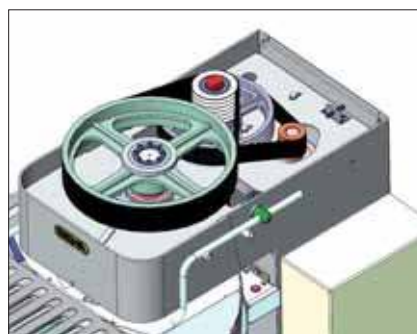

\*Trasmissione Heavy Duty a doppio invio  
\*Heavy Duty double transmission



Pannello di controllo con timer elettromeccanici  
Standard control panel



Pannello di controllo digitale  
Digital control panel



Le impastatrici a spirale con vasca estraibile della serie VE sono la più recente realizzazione di macchine per impieghi di elevate prestazioni e di grande professionalità. Ideali per paste da pane ottengono grandi risultati sullo sviluppo, la raffinazione e l'ossigenazione della pasta. Inoltre, queste impastatrici possono impastare tutte le paste lievitate e tutti gli impasti per prodotti da forno (con meno del 50% di umidità consultare il nostro ufficio tecnico). Il motore che aziona la spirale è stato dimensionato largamente e con grande riserva di potenza è in grado di fornire tutte le coppie necessarie nelle situazioni più gravose. La vasca, la cui rotazione è garantita da ruote di frizione, è azionata da una trasmissione con motore indipendente che consente l'inversione della stessa. Ad un sistema idraulico con pistone di grande diametro ed una centralina indipendente è affidato il compito di aprire e chiudere la macchina per consentire l'estrazione della vasca. La stessa è bloccata, durante gli impasti, da un sistema elettromagnetico di grande potenza e affidabilità. Il pannello comandi è situato in posizione comoda (normalmente a destra) e comprende i pulsanti di apertura e chiusura, mentre la parte operativa è comandata da 2 timer per 1<sup>a</sup> e 2<sup>a</sup> velocità programmabili in automatico. L'apparecchiatura elettrica è situata nel medesimo box stagno con un sistema di pressurizzazione antipolvere, molto comodo per le eventuali ispezioni e la manutenzione.



Die Spiralknetmaschinen mit abnehmbarer Schüssel aus der Serie VE sind neuentwickelte Maschinen für hochwertige, professionelle Anwendungsbereiche. In der Brotherstellung erzielt man sehr gute Ergebnisse, durch die Raffination und Sauerstoffaufnahme des Brotteigs. Diese Knetmaschinen sind für alle Hefe- und Ofengebäck Teige geeignet (für Teige mit weniger als 50% Feuchtigkeit konsultieren Sie unser technisches Büro). Der Motor, welche die Spirale antreibt ist derartig verstärkt, so dass er großen schwerbelastbaren Situationen standhält. Die Schüssel wird über Kupplungsräder von einem unabhängigen Motor angetrieben, somit kann die Schüssel in beide Richtungen vor und zurück drehen. Eine hydraulische Vorrichtung mit Kolben und eine Zentralsteuerung erlauben die Knetmaschine zu öffnen und zu schließen, damit die Schüssel herausgenommen werden kann. Während das Gerät in Betrieb ist, ist die Schüssel durch ein magnetischen Sicherungssystem blockiert. Auf der Schaltvorrichtung, normalerweise rechts am Gerät, sind zwei Schaltknöpfe für das Ein- und Ausschalten des Geräts angebracht. Zwei Geschwindigkeitsgrade können automatisch vorprogrammiert werden. Der elektrische Teil befindet sich in der selben vor Staub und Pulver gesicherter Zinnbüchse mit einem System von Luftverdichtung, die sehr bequem für die Wartung und die eventuellen Überprüfungen ist.



The VE series, spiral mixers with removable bowl are the latest production for advanced performance and high expertise. Great results are achieved for bread dough, thanks to the excellent refining process and oxygenation. In addition, these spiral mixers can knead all types of yeast dough and baking mixtures (for mixtures with less than 50% humidity see technical adviser). The motor that activates the spiral has been widely regulated, with a greater power supply, therefore it can function under the hardest situations. The rotation of the bowl is guaranteed by the friction wheels and works due to an independent transmission motor that allows the bowl an inverse rotation, as well. It is possible to open and close the machine so the bowl can be pulled out thanks to a hydraulic system with a large-sized piston and an independent station. During the kneading procedure, it is blocked by a high-powered, reliable electromagnetic system. The control panel is located in a comfortable spot (usually on the right) and is equipped with opening and closing switches, while the operative part is commanded by 2 timers with a 1<sup>st</sup> and 2<sup>nd</sup> speed that can be programmed automatically. The electrical part is located in the same watertight box with an antidust pressurization system, that is very comfortable for eventual inspections and ordinary maintenance.



Las amasadoras de espiral con cuba extraíble de la serie VE son la más reciente realización de máquinas para elevadas prestaciones y gran profesionalidad. Ideales para masa de pan puesto que se obtienen grandes resultados gracias al óptimo refinado y oxigenación de la masa. Asimismo, estas amasadoras pueden amasar todas las masas fermentadas y todas las masas para productos de repostería (para masas con menos de un 50% de humedad consulte con nuestro departamento técnico). El motor que acciona el espiral se ha dimensionado ampliamente y por lo tanto, con gran reserva de potencia, llega a facilitar todos los pares necesarios en las situaciones más difíciles. La cuba, con rotación garantizada por ruedas de fricción, está accionada por una transmisión con motor independiente que permite su inversión. Un sistema hidráulico con pistón de gran diámetro y una centralita independiente, cumplen la función de abrir y cerrar el aparato para permitir la extracción de la cuba. La misma queda bloqueada, durante el amasado, por un sistema electromagnético de gran potencia y fiabilidad. El panel de mandos está situado en posición cómoda (normalmente a la derecha) e incluye pulsadores de apertura y cierre, mientras que la parte operativa está accionada por 2 temporizadores para 1<sup>a</sup> y 2<sup>a</sup> velocidad programables en automático. El dispositivo eléctrico está situado en el mismo compartimento estanco con un sistema de presurización antipolvo, muy cómodo para posibles controles y su mantenimiento.



La série VE de pétrins à spirale à cuve sortante est la production la plus avancée offrant le meilleur de la technologie. D'exceptionnels résultats sont obtenus pour la pâte à pain grâce au pétrissage affiné et une oxygénation performante. De plus ces pétrins peuvent pétrir tous types de pâtes et mix de préparation (pour des humidités inférieures à 50% voir conseils techniques). Le moteur entraînant la spirale a été grandement dimensionné avec une grande réserve de puissance permettant de travailler dans les conditions les plus difficiles. La rotation de la cuve est obtenue par roues de friction et elle est actionnée par un entraînement indépendant permettant une rotation en sens inverse de la cuve. Le relevage de la tête est actionné par un cylindre hydraulique de grande dimension avec centrale autonome. Lors du pétrissage, la cuve est maintenue par un puissant électro-aimant. Le tableau de commandes est situé sur le côté droit de la machine (en principe) et comporte les boutons de montée et descente alors que la gestion automatique du pétrin est faite à partir de deux minuteries programmables pour les 1<sup>er</sup> et 2<sup>ème</sup> vitesses. L'armoire électrique est située dans le même coffret étanche à l'eau avec système de pressurisation anti poudre, très confortable pour les inspections et éventuelles maintenances.



Спиральные тестомесительные агрегаты со съёмной дежей серии VE - это новая разработка для производства с высокими эксплуатационными качествами и большим профессионализмом. Идеально подходит для процесса замеса хлеба, в результате которого происходит отличный вымес и насыщение кислородом. Кроме того, эти тестомесительные машины способны месить все виды дрожжевого теста и все замесы продукции для выпечки (для замесов с влажностью меньше 50% рекомендуется получить консультацию в нашем техническом отделе). Мотор, приводящий в движение спираль, был рассчитан с большим запасом мощности, поэтому он в состоянии снабдить все необходимые пары в более нагруженных ситуациях. Дежа, вращение которой происходит на колесах фрикционной передачи, приводится в движение независимым мотором, позволяющим инверсию скорости. Открытие и закрытие машины при съёме дежи осуществляются гидравлической системой с поршнем большого диаметра и независимым коммутатором. Во время замеса дежа блокирована электромагнитной системой большой мощности и надёжности. Пульт управления расположен в удобной позиции (как правило, справа) и содержит кнопки открытия и закрытия, в то время как оперативное управление осуществляется с помощью двух таймеров для первой и второй скоростей, которые программируются автоматически. Электрический блок расположен в таком же водонепроницаемом шкафу с пневматической системой защиты против пыли, что очень удобно для периодических проверок и технического обслуживания.



## Panificazione Bakery



IMPASTATRICI  
INDUSTRIALI  
INDUSTRIAL MIXERS

### “Super Premium”

Impastatrici a spirale con vasca estraibile  
Spiral mixers with removable bowl



Modello Model	KW	Peso Weight (Kg)	Alimentazione Voltage	Vasca Bowl (Lt.)	Dimensioni Dimension (mm)
VE 160 SP	9/11	1000	400/3/50	230	1250x1850x1900
VE 200 SP	9/11	1030	400/3/50	290	1250x1850x1900
VE 250 SP	14/18	1060	400/3/50	370	1350x2000x1950
VE 300 SP	14/18	1080	400/3/50	400	1350x2000x1950

Modello Model	Peso Weight (Kg)	Vasca Bowl (Lt.)	Dimensioni Dimension (mm)
Vasca extra/Extra bowl CVE SP 160	235	230	855X880X980
Vasca extra/Extra bowl CVE SP 200	245	290	910X880X1040
Vasca extra/Extra bowl CVE SP 250	280	350	1055X880X1190
Vasca extra/Extra bowl CVE SP 300	295	400	1055X880X1190

#### CARATTERISTICHE TECNICHE GENERALI GENERAL TECHNICAL CHARACTERISTICS

- Vasca, spirale, piantone in acciaio inox
- Due motori: uno per spirale a 2 velocità e uno per vasca con inversione
- Trasmissione a doppio invio
- Tasto impulsi vasca
- Pannello di comando con PLC
- Trazione vasca con ingranaggio
- Regolazione velocità vasca e spirale con inverter
- Piedini regolabili in acciaio inox
- Console di comando con touch-screen su pulpito esterno
- Apertura/chiusura testa con sistema idraulico
- Barra di protezione antinfortunistica
- Normative CE
- Bowl, spiral, shaft in stainless steel
- Two motors: 1 for the 2 speeds spiral and 1 for the bowl with inversion
- Double transmission
- Bowl jogs button
- PLC control panel
- Bowl rotation by gear system
- Bowl speed regulated by inverter
- Stainless steel adjustable feet
- Control board by touch-screen panel on external box
- Mixer head driven by hydraulic system
- Safety protection bar
- CE rules

#### OPTIONALS

- Utensili speciali
- Tensioni speciali
- Potenze maggiorate
- Special tools
- Special tension
- Higher power versions



Le impastatrici della linea SUPER PREMIUM sono impastatrici a spirale con vasca estraibile e rotazione della vasca con ingranaggio per impieghi di elevate prestazioni e di grande professionalità ottenendo grandi risultati di raffinazione e ossigenazione. L'utensile impastatore è azionato mediante una trasmissione a cinghie con doppio rinvio ed un motore che, governato da un inverter, consente la personalizzazione delle sue velocità di rotazione. La trazione della vasca è affidata ad un ingranaggio in materiale plastico che interagisce con una corona dentata posta sotto la vasca e solidale con la stessa, garantendo la possibilità di effettuare la rotazione della vasca anche in presenza di materia grassa ed oleosa sui bordi, la silenziosità e la robustezza. Anche in questo caso un inverter controlla il motore che aziona l'ingranaggio consentendo una regolazione personalizzabile sulla velocità di rotazione della vasca e la sua inversione. Ad un sistema idraulico con pistone di grande diametro ed una centralina indipendente, è affidato il compito di aprire e chiudere la testa della macchina per consentire l'estrazione del carrello vasca, saldamente bloccato durante gli impasti, da un sistema elettromagnetico. Il pannello comandi con PLC è posizionato su un pulpito esterno in posizione comoda, con un pannello touch-screen che consente la memorizzazione delle ricette, la registrazione dei tempi, delle velocità di lavoro e la possibilità di integrazione automatica con il sistema di alimentazione degli ingredienti. La vasca, la spirale ed il piantone centrale in acciaio inox AISI 304, la trasmissione a doppio rinvio, i piedini regolabili in acciaio inox e una barra di protezione antinfortunistica sono dotazioni standard per tutti i modelli.



The mixers of the SUPER PREMIUM line are equipped with a spiral and a removable bowl that rotates through a gear, and will allow you to achieve great refining and oxygenation. The mixer is powered by a belt drive with double transmission and by a motor, controlled by an inverter, that allows you to customize the revolution speed of the tools. The bowl is driven by a plastic gear connected to a crown gear underneath the bowl and fixed to it, thus ensuring the equipment is quiet and resistant. This mechanism rotates the bowl even if there is fat and oily material on the edges. Also in this case, an inverter drives the motor that activates the gear, allowing you to customize the bowl revolution speed and its reversal. A hydraulic system opens and closes the machine head to pull out the bowl trolley that is locked into place during mixing with a powerful and highly reliable. The PLC control panel is conveniently located on an external console, with a touch-screen panel that allows you to store your recipes and mixing process. All models come with bowl, spiral, AISI 304 stainless steel central shaft, double transmission drive, adjustable stainless steel feet and an accident prevention bar.



Les pétrisseuses de la ligne SUPER PREMIUM sont des pétrisseuses Les pétrins spirale SUPER PREMIUM, équipées d'une cuve amovible et de rotation de la cuve avec engrenage, permettent d'obtenir d'excellents résultats de raffinage et d'oxygénation de la pâte. L'outil pétrisseur est actionné par une transmission avec courroies avec double renvoi et un moteur qui, gouverné par un inverseur, permet de personnaliser les vitesses de rotation de l'outil afin de garantir sa polyvalence dans la production de pâte de nombreuses recettes. La traction de la cuve est fait par un engrenage en plastique qui interagit avec une couronne dentée, située sous la cuve et solidaire avec celle-ci, garantissant d'effectuer la rotation de la cuve également en présence de matière grasse et huileuse sur les bords ainsi silence et robustesse. Dans ce cas également, un inverseur contrôle le moteur qui actionne l'engrenage en permettant un réglage personnalisable sur la vitesse de rotation de la cuve et son inversion. Un système hydraulique a pour fonction d'ouvrir et de fermer la tête de la machine afin de permettre l'extraction du chariot-cuve. Ce dernier est bloqué pendant les pétrissages par un système électromagnétique très puissant et fiable. Le tableau de commande doté d'un API est placé sur un pupitre externe, avec un tableau tactile qui permet la mémorisation des recettes et la définition des différentes séquences de pétrissage. La cuve, la spirale et la barre de direction centrale en acier inox AISI 304, la transmission à double renvoi, les pieds réglables en acier inox et une barre de protection et de sécurité font partie de l'équipement standard pour tous les modèles.



Die Teigknetmaschinen der Linie SUPER PREMIUM sind Spiralknetmaschinen mit ausziehbarer Wanne und Drehung der Wanne über ein Zahngetriebe. Mit diesen Maschinen erhält man auch bei Öl und/oder Fett enthaltenden Teigarten ausgezeichnete Ergebnisse bezüglich der Verfeinerung und der Sauerstoffanreicherung. Das Knetwerkzeug wird über einen Riemenantrieb mit doppelter Umlenkung und einen Motor angetrieben. Dieser Motor wird von einem Inverter gesteuert und ermöglicht es, die Drehzahl des Werkzeugs passend einzustellen, um seine Vielseitigkeit beim Teig für zahlreiche Rezepte zu gewährleisten. Der Antrieb der Wanne erfolgt über ein Zahngetriebe aus Kunststoff, das mit einem unterhalb



der Wanne an der Wanne selbst montierten Zahnkranz interagiert und Geräuschlosigkeit und Widerstandsfähigkeit gewährleistet. Dieser Mechanismus ermöglicht es daher, die Drehung der Wanne auch dann vorzunehmen, wenn fettiges oder öliges Material am Wannenrand vorhanden ist. Auch in diesem Fall ist der Motor durch einen Inverter gesteuert, der das Zahngetriebe antreibt und es ermöglicht, die Drehgeschwindigkeit der Wanne sowie die Inversion der Drehrichtung passend einzustellen. Eine Hydraulikanlage mit einem Kolben mit großem Querschnitt und einem unabhängigen Steuergerät sorgt für das Öffnen und Schließen des Maschinenkopfs, damit der Wagen mit der Wanne herausgezogen werden kann. Der Wagen ist während des Knetvorgangs durch ein leistungsstarkes und zuverlässiges elektromagnetisches System blockiert. Die Bedientafel mit PLC ist auf einem externen, in einer bequemen Position befindlichen Steuerpult montiert und verfügt über ein Touchscreen, wodurch es möglich ist, die Rezepte durch Eintragen der Zeiten und der Betriebsgeschwindigkeiten und durch Festlegen der einzelnen Abläufe der Knetvorgänge zu speichern. Es besteht auch die Möglichkeit der automatischen Integration mit der Anlage für die Zufuhr der Zutaten. Die Teigwanne, der Spiralarm und der mittige Stab aus Edelstahl AISI 304, der Antrieb mit doppelter Umlenkung, die einstellbaren Standfüßchen aus Edelstahl und ein Unfallstutzbalken gehören bei allen Modellen zur Standardausrüstung.

Las amasadoras de la línea SUPER PREMIUM presentan una espiral con cuba extraíble y rotación con engranaje con las cuales es posible obtener un refinado y oxigenación de gran calidad. La herramienta de amasado es accionada por una transmisión de correas con doble transmisión y un motor que, controlado por un inversor, permite personalizar las velocidades de rotación. Un engranaje de material plástico efectúa la tracción de la cuba, el cual interacciona con una corona dentada colocada debajo de la cuba y solidaria con la misma, garantizando la posibilidad de efectuar la rotación de la cuba incluso en presencia de materia grasa u oleosa en los bordes, poco ruido y robustez. También en este caso un inverter controla el motor que acciona el engranaje y que permite regular de manera personalizada la velocidad de rotación de la cuba y la inversión de la misma. Un sistema hidráulico con un pistón de grande diámetro y una central independiente efectúan la abertura y cierre del cabezal de la máquina el cual permite la extracción del carro de la cuba bloqueado durante el proceso de amasado da un sistema electromagnético. El panel de mandos con PLC se encuentra colocado en una consola externa en una posición cómoda, con un panel táctil que permite memorizar las recetas a través de la registración del tiempo, las velocidades de trabajo y con la posibilidad de integrarlo de manera automática con el sistema de alimentación de los ingredientes. La cuba, la espiral y el pivote central de acero inoxidable AISI 304, así como la transmisión doble, los pies regulables de acero inox y una barra de protección contra los accidentes se encuentran en el suministro estándar de todos los modelos.



SUPER PREMIUM это спиральные тестомесы со съёмной дежой и вращением дежи на колесах фрикционной передачи. Они являются самой последней и высокопрофессиональной реализацией SIGMA при высокой производительности, и дают отличные результаты вымеса и насыщения кислородом даже теста, содержащего масла и/или жиры. Месильный орган приводится в действие ременной передачей с двойным направлением и мотором, рассчитанным с большим запасом мощности и в состоянии снабдить все необходимые пары в более нагруженных ситуациях. Этот двигатель управляется инвертором и позволяет настраивать скорость вращения месильного органа таким образом, чтобы обеспечить его использование в замесе теста многих рецептов. Тяга дежи поручена пластическовой шестерне, являющейся гарантией тишины и надежности, которая взаимодействует с зубчатым венцом, расположенным под дежой и являющимся ее неотъемлимой частью. Этот механизм позволяет, таким образом вращение дежи и в присутствии масляных и жировых веществ по краям. Также и в этом случае преобразователь управляет двигателем, который приводит в действие механизм, позволяя регулировку скорости вращения дежи и его инверсию. Открытие и закрытие машины при съеме дежи осуществляется гидравлической системой с поршнем большого диаметра и независимым коммутатором. Пульт управления с сенсорной панелью расположен в удобном положении, что позволяет запоминание рецептов через регистрацию времени, рабочей скорости и определения различных последовательностей замеса, с возможностью автоматической интеграции с системой подачи ингредиентов. Дежа, спираль и центральная колонна из нержавеющей стали AISI 304, двойная передача, регулируемые ножки из нержавеющей стали и рычаг защиты безопасности являются стандартом для всех моделей.

IMPASTATRICI  
INDUSTRIALI  
INDUSTRIAL MIXERS



## Panificazione Bakery



GOLD LINE  
BOTTOM DISCHARGE  
SPIRAL MIXERS

### “Gold Line”

Impastatrici a spirale con scarico dal fondo  
Spiral mixers with bottom discharge

Modello Model	KW	Peso Weight (Kg)	Alimentazione Voltage	Vasca Bowl (Lt.)	Dimensioni Dimension (mm)
GL 160 SF	9/11	1300	400/3/50	230	990X1710X1900
GL 200 SF	9/11	1330	400/3/50	290	1050X1770X1900
GL 250 SF	14/18	1350	400/3/50	370	1200X1900X1900
GL 300 SF	14/18	1370	400/3/50	400	1200X1900X1900
Tappeto verticale trasporto pasta H 1.900 + 1 mt Tappeto orizzontale Vertical conveyor belt for dough H 1.900 + 1 mt Horizontal conveyor belt	2,2	-	400/3/50	-	-
Tappeto verticale trasporto pasta H 2.700 + 1 mt Tappeto orizzontale Vertical conveyor belt for dough H 2.700 + 1 mt Horizontal conveyor belt	2,2	-	400/3/50	-	-
Tappeto orizzontale 1 mt Horizontal conveyor belt 1 mt	-	-	-	-	-
Tappeto orizzontale x 1 mtl aggiuntivo Horizontal conveyor belt x 1 mtl additional	-	-	-	-	-

### CARATTERISTICHE TECNICHE GENERALI GENERAL TECHNICAL CHARACTERISTICS

- Vasca, spirale, piantone in acciaio inox
- Due motori: uno per spirale a 2 velocità e uno per vasca con inversione
- Tasto impulsi vasca
- Pannello di comando con PLC
- Trazione vasca con ingranaggio
- Regolazione velocità vasca e spirale con inverter
- Piedini regolabili in acciaio inox
- Console di comando con touch-screen su pulpito esterno
- Apertura/chiusura testa e fondo vasca con sistema idraulico
- Barra di protezione antinfortunistica
- Normative CE
- Bowl, spiral, shaft in stainless steel
- Two motors: 1 for the 2 speeds spiral and 1 for the bowl with inversion
- Bowl jogs button
- PLC control panel
- Bowl rotation by gear system
- Bowl speed regulated by inverter
- Stainless steel adjustable feet
- Control board by touch-screen panel on external box
- Mixer head and bowl discharge hole driven by hydraulic system
- Safety protection bar
- CE rules

### OPTIONALS

- Utensili speciali
- Tensioni speciali
- Potenze maggiorate
- Versione in acciaio inox
- Sonda temperatura per l'impasto
- Raschiatore vasca
- Controllo velocità utensile
- Special tools
- Special tension
- Higher power versions
- Stainless steel version
- Dough thermal probe
- Bowl scraper
- Variable tool speed



Le impastatrici a spirale con scarico dal fondo vasca consentono lo scarico dell'impasto direttamente su di un nastro trasportatore o dentro vasche mobili. Ciò le rende estremamente versatili ed utilizzabili in tutti i processi di impasto, adatte a risolvere problemi di movimentazione e di lay-out del processo produttivo. Il sistema può essere composto da una o più impastatrici per alimentare direttamente una o più linee di produzione oppure un sistema di vasche per la sosta dentro la cella di lievitazione.

La trasmissione a cinghie con rinvio ed il motore che aziona la spirale, sono stati dimensionati largamente con grande riserva di potenza, sono quindi in grado di fornire tutta la coppia necessaria nelle situazioni più gravose.

La vasca, la cui rotazione è garantita da un sistema ad ingranaggio, è azionata da una trasmissione con motore indipendente comandato da un inverter che consente sia la regolazione della sua velocità che l'inversione della stessa. Ad un sistema idraulico è affidato il compito di aprire e chiudere il fondo della vasca e la testa della macchina. La consolle di comando è costituita da un pannello touch-screen che consente la memorizzazione delle ricette ed è situato in posizione comoda su di un pulpito esterno (normalmente a destra) che comprende il pulsante di emergenza e tutte le spie di segnalazione. L'apparecchiatura elettrica è situata nel medesimo box stagno con un sistema di pressurizzazione antipolvere, molto comodo per le eventuali ispezioni e la manutenzione.



Bei den Spiralknetmaschinen, bei denen der Teig unten aus der Wanne entladen wird, kann der Teig direkt auf ein Förderband oder in bewegliche Wannen entladen werden. Dadurch sind sie sehr vielseitig und bei allen Verfahren zum Kneten von Teig verwendbar und können Problemen bei der Beförderung oder des Layouts der Produktionsprozesse bewältigen. Die Anlage kann aus einer oder mehreren Knetmaschinen bestehen, über die eine oder mehrere Produktionslinien direkt mit Teig beschickt werden können, oder auch aus einer Serie Wannen, die für die Lagerung in den Gärzellen bestimmt sind. Der Riemenantrieb mit Umlenkung und der Motor, der die Spirale bewegt, sind so gewählt worden, dass eine beträchtliche Leistungsreserve zur Verfügung steht, daher sind sie in der Lage, auch bei äußerst schwierigen Betriebsbedingungen das notwendige Drehmoment zu liefern. Die Wanne, deren Drehung durch ein Zahnradgetriebesystem gewährleistet ist, wird über einen Antrieb mit unabhängigem, invertergesteuertem Motor angetrieben, sodass sowohl die Einstellung der Drehzahl als auch die Inversion möglich ist. Das Öffnen und Schließen des Wannenbodens und des Kopfs der Maschine erfolgt über eine hydraulische Anlage. Die Bedientafel verfügt über ein Touchscreen-Display, über das die Rezepte gespeichert werden können. Es befindet sich in einer bequemen Position auf einem externen Bedienpult (gewöhnlich rechts), das die Not-Aus-Taste sowie alle Kontrollleuchten enthält. Die elektrische Anlage befindet sich im gleichen, dichten Fach wie die Überdruckanlage gegen den Staub, sodass die Kontroll- und Wartungseingriffe bequem ausgeführt werden können.



The spiral mixers with bottom bowl discharge enable the dough discharge directly on a conveyor belt or into removable bowls. This device makes them very versatile and enables them to be used in all the dough processes. In this way any problems of handling and of the lay-out of the production processes can be solved. A system could be made up of one or more mixers to feed directly one or more production lines or of some bowls resting into the proofing chamber. The belts transmission and the spiral motor have been widely regulated with a greater power supply therefore it can work under the hardest situations. The bowl rotates thanks to a gear system and is moved by a transmission with an independent motor driven by an inverter enabling both its speed regulation and the bowl inversion.

A hydraulic system opens and closes the bowl discharge hole and the mixer head. The control board is made of a touch screen panel that enables the recipes storage. It is located in a comfortable position on an outer box (usually on the right) which also includes the emergency push button and all the indicator lights. The electrical equipment is located in the same watertight box with an anti dust pressurization system what makes the eventual inspections and ordinary maintenance very easy to do.



Las amasadoras en espiral con descarga desde el fondo de la cuba, permiten de scargar la masa directamente sobre una cinta transportadora o dentro de cubas extraíbles. Ésto las hace altamente versátiles y utilizables en todos los procesos de amasado y adecuadas a solucionar los problemas de desplazamiento y de distribución en planta del proceso de producción. El sistema puede estar formado por una o varias amasadoras, para alimentar directamente a una o varias líneas de producción, o bien por un sistema de cubas para la permanencia dentro de la cámara de fermentación. La transmisión por correas con reenvío y el motor que acciona la espiral, han sido dimensionados con mayoración, con una gran reserva de potencia. Son capaces, por lo tanto, de ofrecer el par necesario en las situaciones más difíciles. La cuba, que gira gracias a un sistema de engranajes, está accionada por una transmisión con un motor independiente dirigido por un inverter, que permite tanto la regulación de su velocidad como la inversión de la misma. El sistema puede estar formado por una o varias amasadoras, para alimentar directamente a una o varias líneas de producción, o bien por un sistema de cubas para la permanencia dentro de la cámara de fermentación. La transmisión por correas con reenvío y el motor que acciona la espiral, han sido dimensionados con mayoración, con una gran reserva de potencia. Son capaces, por lo tanto, de ofrecer el par necesario en las situaciones más difíciles. La cuba, que gira gracias a un sistema de engranajes, está accionada por una transmisión con un motor independiente dirigido por un inverter, que permite tanto la regulación de su velocidad como la inversión de la misma.



Les pétrins à spirale avec déchargement du fond de la cuve permettent le déchargement de la pâte directement sur une bande transporteuse ou dans des cuves mobiles. Cela les rend extrêmement éclectiques et utilisables pour tous les procédés de pétrissage et adaptables à résoudre des problèmes de manutention et de mise en page du procédé de production. Le système peut être composé d'une ou de plusieurs pétrins pour alimenter directement une ou plusieurs lignes de production ou un système de cuves pour l'arrêt dans la cellule de fermentation de la pâte. La transmission à courroi est avec renvoi et le moteur qui actionne la spirale ont été largement dimensionnés, avec une grande réserve de puissance, ils sont donc toutes en mesure de fournir le couple nécessaire dans les situations les plus lourdes. La cuve, dont la rotation est assurée par un système à engrenages, est actionnée par une transmission avec un moteur indépendant commandé par un inverter qui permet aussi bien le réglage de sa vitesse que l'inversion de cette dernière. Un système hydraulique s'occupe d'ouvrir et de fermer le fond de la cuve et la tête de la machine. La console de commandes est constituée d'un panneau écran-tactile, permettant de mémoriser des recettes, qui est placé dans une position commode, sur un pupitre externe (normalement à droite) et comprenant le bouton d'urgence et tous les voyants de signalisation. L'appareillage électrique est situé dans le même box étanche avec un système de pressurisation anti-poussière, très commode pour d'éventuelles inspections et pour la maintenance.



Спиральные тестомесильные машины с выгрузкой со дна дежи позволяют выгрузку теста непосредственно на ленточный транспортер или в откатные дежи. Это позволяет использование этих тестомесов на всех стадиях замеса, которые легко адаптируются для решения задач обработки и планировки производственного процесса. Ременный привод с коробкой передач и двигатель, приводящий в действие спираль, рассчитаны с большим запасом мощности, поэтому они в состоянии снабдить все необходимые пары в наиболее нагруженных ситуациях. Дежа, вращение которой обеспечивается с помощью системы передачи, приводится в движение независимым двигателем, управляемым инвертером, который позволяет как регулировку скорости, так и ее инверсию. Открытие и закрытие дна дежи и ее головы осуществляется гидравлической системой. Пульт управления состоит из сенсорной панели, позволяющим хранение рецептов, расположен он в удобной позиции (как правило, справа) который включает в себя аварийную кнопку и все сигнальные лампы. Электрический блок расположен в водонепроницаемом шкафу с пневматической системой защиты против пыли, что очень удобно для периодических проверок и технического обслуживания. Полная версия из нержавеющей стали, специальные инструменты, термический зонд для теста, скребок для дежи и система контролируемого изменения скорости инструмента могут быть предоставлены в качестве опций.



## Panificazione Bakery



### “Impastatrici a bracci tuffanti”

Twin arms mixers



Modello Model	KW	Peso Weight (Kg)	Alimentazione Voltage	Dimensioni Dimension (mm)
IBT 40	1,1/1,5	300	400/3/50	720x1430x1660
IBT 50	1,1/1,5	320	400/3/50	785x1500x1660
IBT 60	1,1/1,5	340	400/3/50	885x1760x1900
IBT 80	1,5/2,2	525	400/3/50	940x1830x1900
IBT 120	2,5/4,0	720	400/3/50	1050x1950x1900
IBT 160	2,5/4,0	770	400/3/50	1050x1950x1900

#### CARATTERISTICHE TECNICHE GENERALI GENERAL TECHNICAL CHARACTERISTICS

- Struttura in acciaio saldato
- Parti meccaniche in movimento in bagno d'olio
- Vasca, bracci, riparo in acciaio inox speciale
- Braccio regolabile in altezza
- Due velocità
- Ruote
- Normative CE
- Welded steel body
- Gears in oil bath
- Bowl, arms, protection in special stainless steel
- Fork arm adjustable in height
- Double speed
- Wheels
- CE rules

#### OPTIONALS

- Tensioni Speciali
- Timers
- Versioni Inox
- Special tensions
- Timers
- Stainless steel version



Impastatrice indispensabile nelle pasticcerie, nei panifici, nelle industrie dolciarie e nelle pizzerie. Il sistema a bracci tuffanti favorisce l'ossigenazione dell'impasto e riduce il riscaldamento dello stesso, permettendo così di ottenere ottimi risultati nel prodotto finale. La mobilità dei bracci contribuisce a migliorare ulteriormente la qualità dell'impasto. La struttura della macchina è in acciaio verniciato di grosso spessore; tutti i modelli sono robusti, silenziosi ed affidabili. La vasca, i bracci e la griglia sono in acciaio inox speciale. Gli ingranaggi di trasmissione dei bracci sono in ghisa speciale, immersi in bagno d'olio. La macchina è montata su cuscinetti a sfera, è dotata di due velocità e timer se richiesto. Tutte le parti sono facilmente smontabili per eventuali sostituzioni. Macchina montata su ruote e costruita in conformità alle norme CE.



Diese Knetmaschine ist für Konditoreien und Bäckereien sowie der Süßwarenindustrie und in Pizzerien unentbehrlich. Das System der eintauchenden Arme begünstigt die Sauerstoffanreicherung der Masse und senkt gleichzeitig deren Überhitzung. Hierdurch kann ein optimales Endprodukt erzeugt werden. Die Beweglichkeit der Arme trägt zur weiteren Verbesserung der Qualität der Masse bei. Die Struktur der Maschine besteht aus lackiertem Stahl von hoher Stärke. Alle Modelle sind widerstandsfähig, geräuscharm und zuverlässig. Die Wanne, die Arme und das Gitter bestehen aus rostfreiem Spezialstahl. Die Getriebegänge der Arme sind aus speziellem Gusseisen gefertigt und befinden sich in einem Ölbad. Die Maschine ist auf Kugellager montiert und verfügt über zwei Geschwindigkeiten sowie, auf Anfrage, über eine Zeitschaltuhr. Alle Komponenten sind für einen eventuellen Austausch leicht auseinander zu bauen. Maschine auf Räder montiert und entsprechend der EU-Normen gebaut.



Essential mixer for pastry shops, bakeries, confectionary industries and pizzeria. The twin arms system oxygenates the dough and reduces the heating of the same, obtaining thus excellent results in the final product. The mobility of the arms improves the quality of the dough. The structure of the machine is of thick painted steel; all models are sturdy, silent and reliable. The bowl, the arms and the guard are made of special stainless steel. The arms drive gears are of special cast iron in oil bath. The machine is mounted on ball bearings and is supplied with two speeds and optional timer. All the parts can be easily disassembled for replacement. The machine is fitted on wheels and manufactured in accordance with EC norms.



Amasadora indispensable en la pastelería, la panadería, en las industrias confiteras y en las pizzerías. El sistema con brazos recortadores favorece la oxigenación del amasijo y reduce el calentamiento, lo que permite obtener óptimos resultados en el producto final. La movilidad de los brazos contribuye a mejorar la calidad del amasijo. La estructura de la máquina es de acero pintado de espesor grueso; todos los modelos son sólidos, silenciosos y fiables. La cuba, los brazos y la rejilla son de acero inoxidable especial. Los engranajes de transmisión de los brazos son de hierro fundido, inmersos en baño de aceite. La máquina está montada sobre rodamientos de esfera, presenta dos velocidades y temporizador si se solicita. Todas las partes son fáciles de desmontar para realizar las sustituciones. Máquina montada sobre ruedas y fabricada según las normas CE.



Pétrin indispensable pour les pâtisseries, les boulangeries, les industries de confiseries et les pizzerias. Le système à bras plongeurs favorise l'oxygénation de la pâte et réduit son réchauffement en permettant ainsi d'obtenir de très bons résultats du produit final. La mobilité des bras contribue à améliorer ultérieurement la qualité de la pâte. La structure de la machine est en acier verni d'une grosse épaisseur; tous les modèles sont solides, silencieux et fiables. La cuve, les bras et la grille sont en acier inoxydable spécial. Les engrenages de transmission des bras sont en fonte spéciale, immergés dans un bain d'huile. La machine est montée sur des roulements à billes, elle est équipée de deux vitesses et d'un minuteur, si demandé. Toutes les parties sont facilement démontables pour d'éventuels remplacements. La machine est montée sur roues et fabriquée conformément aux normes CE.



Тестомесильная машина, необходимая для кондитерских цехов, пекарен, пиццерий. Машины со двоянной лопастью насыщают тесто кислородом и снижают нагрев, что положительно влияет на конечный продукт. Подвижность лопастей улучшает качество теста. Конструкция машины изготовлена из толстой окрашенной стали. Все модели прочны, бесшумны и надежны. Дежа, лопасти и защитная решетка изготовлены из специальной нержавеющей стали. Ведущие механизмы лопастей из специального чугуна в масляной ванне. Машина оснащена шарикоподшипниками, имеет две скорости и дополнительный таймер. Все детали можно легко разобрать и заменить. Машина установлена на колеса и изготовлена в соответствии с требованиями европейских стандартов.



## Panificazione Bakery



### “Impastatrici a Forcella”

Fork mixers



Modello Model	KW	Peso Weight (Kg)	Alimentazione Voltage	Vasca Bowl (Lt.)	Dimensioni Dimension (mm)
FM125	2,5	230	400/3/50	125	1200X800X950
FM200	3,2	465	400/3/50	200	1300X900X1050
FM300	5	510	400/3/50	300	1350X1100X1250

#### CARATTERISTICHE TECNICHE GENERALI GENERAL TECHNICAL CHARACTERISTICS

- Struttura in acciaio saldato
- Parti meccaniche in movimento in bagno d'olio
- Vasca, Utensile e Griglia di protezione in acciaio inox
- Motore Forcella a due velocità
- Velocità della vasca regolabile
- Welded Steel body
- Gears in oil bath
- Bowl, fork and grid protection in stainless steel
- Two speeds of mixing
- Bowl speed regulated by breaking system

#### OPTIONALS

- Versione inox
- Tensioni Speciali
- Motore per la vasca  
Timers
- Stainless steel body
- Special tensions
- Bowl Motor
- Timers



Le impastatrici a FORCELLA sono macchine tradizionali robuste e affidabili, costruite in lamiera d'acciaio di grosso spessore, con una meccanica in bagno d'olio che ne garantisce la silenziosità e la durata nel tempo.

Particolarmente adatte per paste molto idratate, con il loro utensile dallo speciale design sono garanzia di omogeneità e di alta qualità di impasto, permettendo allo stesso di inglobare una grossa quantità d'aria senza surriscaldamento, mantenendo quindi inalterate le caratteristiche organolettiche della pasta.

I componenti a contatto con il prodotto: vasca, forcella e griglia di protezione sono in acciaio inox AISI 304. Le parti di comando, posizionate sul corpo macchina, sono di semplice utilizzo e di facile accesso e rispettano le normative CE vigenti.



The Sigma Fork Mixers are traditional machines with a solid and sturdy construction robust and reliable. They are made with thick steel frame, with a mechanical gear in oil bath which guarantees its quiet operation and durability.

Particularly suitable for very hydrated doughs, with their tool by the special design are a guarantee of homogeneity and high quality of dough, allowing to incorporate a large quantity of air without overheating, thus maintaining the organoleptic characteristics of the dough.

The components in contact with the product: bowl, fork and protection grid are in stainless steel AISI 304. The control panel, positioned on one side of the machine, is easy to use and easy to access and comply with CE regulations.



Les pétrisseuses à FOURCHE sont des machines traditionnelles solides et fiables, fabriquées en tôle d'acier de grosse épaisseur, avec une mécanique à bain d'huile qui garantit un fonctionnement silencieux et une durée au fil du temps.

Particulièrement indiquées pour travailler des pâtes très hydratées, grâce à leur outil présentant un design spécial, elles garantissent une homogénéité et une grande qualité de mélange, permettant à ce dernier d'englober une grosse quantité d'air sans surchauffe, maintenant donc inaltérées les caractéristiques organoleptiques de la pâte.

Les composants en contact avec le produit : la cuve, la fourche et la grille de protection sont en acier inox AISI 304. Les pièces de commande, situées sur le corps de la machine, sont simples à utiliser, faciles d'accès et respectent les normes CE en vigueur.



Die GABELKNETER sind robuste und zuverlässige traditionelle Maschinen aus dickwandigem Stahlblech mit Ölbadmechanik, die Geräuscharm und eine lange Lebensdauer gewährleistet.

Besonders geeignet für sehr hydrierte Teige, gewährleisten sie mit ihrem speziell designten Werkzeug die Homogenität und die hohe Qualität der Teigmasse, weil sie dieser die Aufnahme einer großen Luftmenge ohne Überhitzung erlauben und somit die wahrnehmbaren Eigenschaften des Teigs unverändert belassen.

Die mit dem Produkt in Kontakt stehenden Bauteile: Wanne, Gabel und Schutzgitter sind aus Edelstahl AISI 304. Die Bedienteile befinden sich am Gehäuse, sind einfach zu benutzen, leicht erreichbar und entsprechen den geltenden EG-Richtlinien.



Las amasadoras FORCELLA son máquinas tradicionales resistentes y fiables, fabricadas en chapa muy espesa de acero, con una mecánica en baño de aceite que garantiza un trabajo silencioso y una larga duración.

Especialmente adecuadas para masas muy hidratadas, garantizan la homogeneidad y la alta calidad de la masa gracias a su herramienta con un diseño especial, permitiendo al mismo tiempo englobar una gran cantidad de aire sin sobrecalentamiento, manteniendo por lo tanto inalteradas las características organolépticas de la pasta.

Los componentes en contacto con el producto: cuba, horquilla y rejilla de protección son de acero inoxidable AISI 304. Las partes de mando, colocadas en el cuerpo de la máquina, son fáciles de usar, a ellas se llega fácilmente y respetan las normas CE vigentes.



Вилковые тестомесы - это традиционные прочные и надежные машины, изготовленные из толстой листовой стали, с механическими компонентами в масляной ванне, которая гарантирует его тихую работу и долговечность.

Они особенно подходят для очень гидратированного теста. Их месильный орган специальной конструкции являются гарантией однородности и высокого качества теста, позволяя ему насыщаться наибольшим количеством воздуха не перегреваясь, тем самым сохраняя органолептические характеристики теста.

Компоненты, контактирующие с продуктом: дежа, вилка и защитная решетка, изготовлены из нержавеющей стали AISI 304. Части управления, расположенные на корпусе машины, просты в использовании, легко доступны и соблюдают правила CE.



## Panificazione Bakery



### “Maciste”

Sollevatori per vasche estraibili  
Spiral mixer Lifters



MaCiste  
Lifter

Modello Model	KW	Peso Weight (Kg)	Alimentazione Voltage	Altezza scarico Discharge (mm)	Portata Lifting capacity (Kg)	Dimensioni aperto Dimension opened (mm)	Dimensioni chiuso Dimension closed (mm)
MACISTE 1300	2,2	480	400/3/50	1300	400	2180X1500X2730	2300X1540X1350
MACISTE 1600	2,2	510	400/3/50	1600	400	2180X1500X3030	2300X1540X1650
MACISTE 1900	2,2	540	400/3/50	1900	400	2180X1500X3330	2300X1540X1950
MACISTE 2700	2,2	560	400/3/50	2700	400	2180X1500X4030	2300X1540X2750

H. SCRAPER

Raschiatore automatico per Maciste - Automatic Maciste scraper

#### CARATTERISTICHE TECNICHE GENERALI GENERAL TECHNICAL CHARACTERISTICS

- Struttura in acciaio elettrosaldato con vie di corsa galvanizzate
- Anello di protezione antinfortunistica
- Gambe di appoggio a pavimento in acciaio inox
- Centralina Idraulica a vista
- Normative CE
- Certificazione ETL e GOST
- Sistema di alzata idraulico con ribaltamento a levismo
- Structure in electrowelded steel with galvanized paths
- Safety protection ring
- Floor supporting legs in stainless steel
- Hydraulic control board at sight
- CE rules
- ETL and GOST certification
- Hydraulic lifting system with tilting

#### OPTIONALS

- Tensioni speciali
- Personalizzazione altezze scarico
- Raschiatori con rotazione vasche
- Adattamento vasche altri produttori
- Scivolo teflonato
- Special tensions
- Customized dimensions
- Scrapers with bowl rotation
- Different bowls adjustment
- Tefloned chute



MACISTE è un sollevatore, rovesciatore, per vasche carrellate di impastatrici a vasca estraibile. È caratterizzato da una robusta struttura elettrosaldata in acciaio con guide di scorrimento e carro simili ai migliori sistemi di sollevamento dei carrelli elevatori. Affidabilità totale e semplicità sono le caratteristiche più importanti. Il sollevamento e il ribaltamento avvengono in sequenza con l'uso di un solo potente pistone idraulico che mediante doppia catena compie l'intero percorso. Il sollevatore Maciste è prodotto in tre versioni differenti fra loro per la diversa altezza di scarico: 1,3 mt, 1,9 mt e 2,6 mt. Peso massimo sollevabile kg 400.



MACISTE Es handelt sich um eine Hebe-/Kippvorrichtung für herausziehbare Knetmaschinenwannen mit Fahrwerk. Diese besteht aus einer widerstandsfähigen, elektrisch geschweißten Stahlkonstruktion mit Gleitführungen und Wagen, die den besten Hubsystemen von Gabelstapler ähnlich sind. Ihre wichtigsten Eigenschaften sind daher vollkommene Zuverlässigkeit und einfache Gebrauch. Das Heben und Kippen erfolgt nacheinander, ausgelöst durch einen einzigen kräftigen Hydraulikkolben, der mithilfe einer doppelten Kette den gesamten Lauf vollführt. Die Hebevorrichtung Maciste wird in drei verschiedenen Ausführungen produziert, die sich untereinander durch ihre Entladehöhe unterscheiden: 1,3 m, 1,9 m und 2,6 m. Zulässiges Höchstgewicht der Last 400 kg.



MACISTE is a tipper for bowls on wheels of spiral mixers with removable bowl. It is characterized by an electro welded sturdy steel structure with slide guides and trolley similar to the best lifting systems of lift trucks. Therefore the main characteristics are total reliability and simplicity. The lifting and the unloading occur one after the other by the use of one powerful hydraulic piston that, thanks to a double chain, makes the complete course. The lifter Maciste is produced in three versions according to the different discharge height: 1,3 mt, 1,9 mt and 2,6 mt. Maximum lifting weight 400 kg.



MACISTE es un elevador, volteador, para cubas con carro de amasadoras con cuba extraíble. Se caracteriza por una sólida estructura electrosoldada de acero con guías de deslizamiento y carro similares a los mejores sistemas de elevación de carros elevadores. Por lo tanto, la fiabilidad total y la simplicidad son las características más importantes. La elevación y el vuelco se realizan en secuencia con el uso de un solo poderoso pistón hidráulico que con doble cadena realiza todo el recorrido. El elevador Maciste se produce en tres versiones diferentes entre sí para las diferentes alturas de descarga: 1,3 m, 1,9 m y 2,6 m. Peso máximo elevable, 400 Kg.



MACISTE c'est un basculeur de cuves sur roulettes de pétrins à cuve sortante. Il est caractérisé par une structure robuste et électro-soudée en acier avec guide de coulissement et chariot similaires aux meilleurs systèmes de soulèvement des chariots éleveurs. Ses caractéristiques principales sont donc parfaitement fiables et simples. Le soulèvement et le renversement se produisent l'un après l'autre en utilisant un seul piston hydraulique puissant, qui grâce à une double chaîne réalise le parcours entièrement. Le basculeur Maciste est produit en trois différentes versions selon les hauteurs de déchargement: 1,3 m, 1,9 m et 2,6 m. Poids maximum soulevable 400kg.



MACISTE Это – подъемное устройство для деж на колесах для машин тестомесильных спиральных с подкатными дежами. Это – прочная электросварная конструкция с направляющими и тележкой, аналогична лучшим подъемным системам из ряда подъемников. Главными характеристиками являются полная надежность и простота. Подъем и выгрузка осуществляются последовательно с помощью одного мощного гидравлического поршня, который, благодаря использованию двойной цепи, осуществляет весь процесс. Дежеподъемник Maciste изготавливают трех моделей в соответствии с различной высотой подъема: 1,3 м, 1,9 м и 2,6 м. Максимальный вес для подъема 400 кг.



## Panificazione Bakery



### “MacisteMax”

Sollevatori per vasche estraibili  
Spiral mixer Lifters



MaCisteMax  
Lifter

Modello Model	KW	Peso Weight (Kg)	Alimentazione Voltage	Altezza scarico Discharge (mm)	Portata Lifting capacity (Kg)	Dimensioni aperto Dimension opened (mm)	Dimensioni chiuso Dimension closed (mm)
MACISTE MAX 1600	2,2	610	400/3/50	1600	600	2400X1500X3100	2400X1540X1750
MACISTE MAX 1900	2,2	640	400/3/50	1900	600	2400X1500X3400	2400X1540X2050
MACISTE MAX 2700	2,2	660	400/3/50	2700	600	2400X1500X4400	2400X1540X2850

#### H. SCRAPER

Raschiatore automatico per Maciste - Automatic Maciste scraper

#### CARATTERISTICHE TECNICHE GENERALI GENERAL TECHNICAL CHARACTERISTICS

- Struttura in acciaio elettrosaldato con vie di corsa galvanizzate
- Anello di protezione antinfortunistica
- Gambe di appoggio a pavimento in acciaio inox
- Centralina Idraulica a vista
- Normative CE
- Certificazione ETL e GOST
- Sistema con ribaltamento indipendente con coppia di pistoni idraulici
- Structure in electrowelded steel with galvanized paths
- Safety protection ring
- Floor supporting legs in stainless steel
- Hydraulic control board at sight
- CE rules
- ETL and GOST certification
- Independent tilting system with double hydraulic pistons

#### OPTIONALS

- Tensioni speciali
- Personalizzazione altezze scarico
- Raschiatori con rotazione vasche
- Adattamento vasche altri produttori
- Scivolo teflonato
- Special tensions
- Customized dimensions
- Scrapers with bowl rotation
- Different bowls adjustment
- Tefloned chute



MACISTE MAX è un sollevatore simile per struttura al Maciste, con la sola differenza che il sollevamento è affidato ad un pistone a doppia catena di sollevamento mentre il ribaltamento è affidato ad una coppia di pistoni indipendenti di grande potenze e affidabilità. È presente un riparo antinfortunistico di protezione della zona lavoro mentre i comandi sono in posizione ergonomica e di facile uso. Le gambe di appoggio a terra sono in acciaio inox e provviste di fori per il fissaggio. Il sollevatore in oggetto è costruito in due altezze standard per altezza di scarico mt 1,9 e mt 2,6, misure speciali sono costruite a richiesta. Peso massimo sollevabile Kg 600.



MACISTE MAX is a lifter very similar, for its structure, to the Maciste one. The only difference is that the lifting is assigned to one piston with a double raising chain while the turning over is assigned to a couple of independent, powerful and reliable pistons. The working area is sheltered by a safety protection and the control system is located in an ergonomic position and is easy to use. The supporting legs are in stainless steel and provided with holes. This lifter is produced in two versions according to the different discharge height: 1,9 mt and 2,6 mt, but special measurements can be built on request. Maximum lifting weight 600 Kg.



MACISTE MAX c'est un basculeur similaire au Maciste du point de vue de la structure. L'unique différence est que le soulèvement est transmis par un piston à double chaîne de soulèvement alors que le renversement est transmis par un couple de pistons indépendants, très puissants et fiables. La zone de travail est protégée par une protection anti-accident et les commandes sont situées en position ergonomique et faciles à utiliser. Les pieds d'appui sont en acier inox et pourvus de trous pour le fixation. Le basculeur est construit en deux différentes versions selon les hauteurs de déchargement : 1,9m et 2,6m. Sur demande, il est possible de construire des basculeurs sur mesure. Poids maximum soulevable 600 Kg.



MACISTE MAX Die Konstruktion dieser Hebevorrichtung ähnelt der von Maciste mit dem einzigen Unterschied, dass hier das Heben über einen Kolben mit doppelter Kette erfolgt während das Kippen mithilfe zweier unabhängiger Kolben durchgeführt wird, die über eine hohe Kraft und Zuverlässigkeit verfügen. Der Arbeitsbereich verfügt über eine Schutzabdeckung und die Steuerung befindet sich in einer ergonomisch vorteilhaften Position und ist einfach zu bedienen. Die Stützfüße bestehen aus rostfreiem Stahl und sind mit Bohrungen zur Befestigung versehen. Die besagte Hebevorrichtung erst in zwei unterschiedlichen Höhen für eine Ausladungshöhe von 1,9 m und 2,6 m erhältlich. Ausführungen mit speziellen Abmessungen können auf Anfrage gebaut werden. Zulässiges Höchstgewicht der Last 600 kg.



MACISTE MAX es un elevador similar en estructura al Maciste, con la única diferencia de que la elevación la realiza un pistón de doble cadena de elevación mientras que el vuelco se realiza con un par de pistones independientes de gran potencia y fiabilidad. Presenta una protección contra accidentes en la zona de trabajo, mientras que los mandos están en posición ergonómica y fácil de usar. Las patas de apoyo en el suelo son de acero inoxidable y presentan agujeros para la fijación. El elevador en cuestión esta fabricado en dos alturas estándar para altura de descarga de 1,9 m y 2,6 m, medidas especiales se fabrican a pedido. Peso máximo elevable, 600 Kg.



MACISTE MAX Этот дежеподъемник очень похож по конструкции на модель Maciste. Единственным отличием является то, что подъем осуществляется с помощью одно- го поршня с двойной подъемной цепью, в то время как опрокидывание осуществляется благодаря паре независимых, мощных и надежных поршней. Рабочая площадка огорожена защитным поруч- нем, а панель управления установлена в удобном положении, и ею легко пользоваться. Опорная стойка изготовлена из нержавеющей стали и име- ет отверстия для выгрузки на высоте 1,9 м и 2,6 м, но по заказу можно изготовить дежеподъемник со специальной высотой выгрузки. Максимальный вес для подъема 600 кг.



## Panificazione Bakery



### “Hercules”

Sollevatori per vasche estraibili  
Spiral mixer Lifters



**Hercules**  
Lifter

Modello Model	KW	Peso Weight (Kg)	Alimentazione Voltage	Altezza scarico Discharge (mm)	Portata Lifting capacity (Kg)	Dimensioni aperto Dimension opened (mm)	Dimensioni chiuso Dimension closed (mm)
HERCULES 3600	3	980	400/3/50	2270+3600	800	2800X1530X5175	2800X1530X2200

H. SCRAPER

Raschiatore automatico per Hercules - Automatic Hercules scraper

### CARATTERISTICHE TECNICHE GENERALI GENERAL TECHNICAL CHARACTERISTICS

- Struttura di sollevamento con castello di elevazione a doppio stadio
- Sistema di regolazione altezza di scarico da 2270 a 3800mm
- Dimensioni di ingombro a sollevatore chiuso molto compatte
- Ribaltamento indipendente con coppia di pistoni idraulici
- Gambe di appoggio a pavimento in acciaio inox
- Anello di protezione antinfortunistica
- Centralina Idraulica ubicata all'interno del basamento
- Normative CE
- Certificazione ETL e GOST
- Unloading height adjustment system from 2270 to 3800mm
- Very reduced overall dimensions when lifter is closed
- Independent tilting system with couple of hydraulic pistons
- Floor supporting legs in stainless steel
- Safety protection ring
- Hydraulic control board inside the basement
- CE rules
- ETL and GOST certification

### OPTIONALS

- Tensioni speciali
- Personalizzazione altezze scarico
- Raschiatori con rotazione vasche
- Adattamento vasche altri produttori
- Scivolo teflonato
- Special tensions
- Customized dimensions
- Scrapers with bowl rotation
- Different bowls adjustment
- Tefloned chute



Nato da una esigenza connessa alla logistica nella produzione di impasti, ha il compito di sollevare e rovesciare vasche carrellate ad altezze preimpostate che vanno da un minimo di mt 2,2 ad un massimo di mt 3,8. Si voleva uno strumento capace di scaricare ad altezze variabili e considerevoli senza che avesse dimensioni troppo importanti per la facilità di trasporto, installazione e razionalizzazione degli spazi. Infatti la sua dimensione, a macchina chiusa, non supera i mt 2,2, quindi adatto al carico su camion, container ecc. Il principio è semplice, è stata utilizzata una struttura standard di un carrello elevatore a doppio sfilamento con portata massima di kg 2500, elemento super collaudato e di sicura affidabilità. È stata costruita una struttura di rovesciamento a doppio pistone, perfettamente bilanciato, il tutto montato su un supporto con gambe di appoggio e fissaggio adeguate al sollevatore. All'interno del supporto è alloggiata la centralina idraulica dimensionata largamente per un uso continuo. A completamento dei sistemi di sicurezza la zona dove opera il carrello con vasca è protetta da un anello che delimita lo spazio sotto la vasca stessa. A richiesta è possibile chiuderlo in un box con cancello di sicurezza per delimitare la zona di potenziale pericolo. Peso Massimo Sollevabile kg 800.



Für das Heben und Kippen von Wannen mit Fahrwerk und einer vorgegebener Größe von mindestens 2,2 m und höchstens 3,8 m ist ein Gerät notwendig, dass in variabler und relativ großer Höhe entladen kann ohne dabei selbst besonders groß zu sein, damit der Transport sowie die Installation vereinfacht werden und der benötigte Platz so gering wie möglich gehalten wird. Bei geschlossener Vorrichtung ist dieses Gerät nicht größer als 2,2 m und somit geeignet, um auf einen LKW, Container etc. geladen zu werden. Dem unterliegt ein einfaches Prinzip. Es wurde die Standardkonstruktion eines Gabelstaplers mit doppelten Auszug und einer maximalen Traglast von 2500 kg verwendet. Dieses Element ist unzählige Male erprobt worden und von hoher Zuverlässigkeit. Konstruiert wurde eine perfekt ausbalancierte Kippvorrichtung mit zwei Kolben, die auf Stützfüße montiert und an der Hebevorrichtung entsprechend befestigt ist. Im Sockel befindet sich die Hydraulikeinheit, deren Größe an einen Dauerbetrieb angepasst ist. Zur Vervollständigung der Sicherheitssysteme ist der Bewegungsbereich des Wagens mit Wanne durch einen Ring geschützt, der den Abstand unter der Wanne selbst begrenzt. Auf Anfrage kann dieser in einer Box mit Sicherheitsgittertür eingeschlossen werden, damit die potenzielle Gefahrenzone abgegrenzt wird. Zulässiges Höchstgewicht der Last 800 kg.



Born from a logistics need in the production of dough, it has the duty to lift and discharge wheeled bowls at pre-set heights from min. m 2,2 to max m 3,8. We wanted a device able to discharge at variable and remarkable heights but without too big dimensions for an easy transport, installation and room rationalization. As a matter of fact its dimensions, when the machine is closed, do not overpass 2,2 m, therefore it is suitable for trucks, containers and so on. The principle is simple: a standard structure of an elevator trolley with a maximum load of kg. 2500, a well-ried and reliable element. A discharging structure with double, perfectly balanced pistons has been made; the whole device is mounted on a stand with support and fixing legs suitable to the lifter. Inside the support a largely dimensioned hydraulic control unit is located for a continuous use. On completion of the security systems, the area where the trolley operates is protected by a ring that delimits the space under the bowl itself. It is possible, on demand, to close it in a box with a safety gate to delimit the zone of potential danger. Maximum lifting weight 800 Kg.



Nacido de una necesidad conectada a la logística en la producción de amasijos, tiene la función de elevar y verter cubas con carro a alturas definidas previamente que van desde un mínimo de 2,2 m hasta un máximo de 3,8 m. Se deseaba un instrumento capaz de descargar a alturas variables y considerables sin que haya dimensiones demasiado importantes por la facilidad de transporte, instalación y racionalización de los espacios. De hecho, su medida, con la máquina cerrada, no supera los 2,2 m, por lo que se puede cargar sobre un camión, contenedor, etc. El principio es simple, se utilizó una estructura estándar de un carro elevador de doble apertura con capacidad máxima de 2500 Kg, elemento súperconectado y de fiabilidad segura. Se construyó una estructura de vuelco con doble pistón, perfectamente balanceada, todo montado sobre un soporte con patas de apoyo y fijación adecuadas para el elevador. Dentro del soporte se encuentra la centralita hidráulica dimensionada ampliamente para el uso continuo. Para completar los sistemas de seguridad, la zona en donde funciona el carro con cuba está protegida por un anillo que delimita el espacio debajo de la cuba. A pedido, es posible cerrarlo en una rejilla de seguridad para delimitar la zona de peligro potencial. Peso máximo elevable, 800 Kg.



Né d'une exigence liée à la logistique dans la production de pétrissage, Hercules a le devoir de soulever et de renverser des cuves sur roulettes à des hauteurs préétablies qui vont d'une minimale de 2,2 m à une maximale de 3,8 m. Nous voulions un instrument capable de décharger à des hauteurs variables et considérables sans avoir des dimensions énormes afin de faciliter le transport et l'installation et d'être rationnels aux espaces. En fait ses dimensions, machine fermée, ne dépassent pas les 2,2 m. Il est donc adapté pour être chargé dans un camion, container, etc. Le principe est simple : nous avons utilisé la structure standard d'un chariot élévateur à double égrenage avec une portée maximale de 2500 kg, élément mis au point et fiable. Nous avons construit une structure de renversement à double piston, parfaitement équilibrée, le tout monté sur un support aux pieds d'appui et de fixation adéquats au soulèvement. A l'intérieur du support est logée une centrale hydraulique convenablement conçue pour une utilisation continue. Pour compléter les systèmes de sécurité, la zone de travail du chariot de cuve est protégée par un anneau qui délimite l'espace sous la cuve même. Sur demande, il est possible de l'enfermer dans une portail de sécurité pour délimiter la zone de danger. Poids maximum soulevable 800 kg.



Созданный для целей логистики при производстве теста он осуществляет подъем и выгрузку деж на ко- лесах на заранее установленную высоту от 2,2 м мини- мально до 3,8 м максимально. Нам было необходимо устройство, способное осуществлять выгрузку теста на различную, установленную высоту, но небольших габаритов для его легкой транспортировки, установ- ки и экономии места в помещении. Кстати, габариты, когда дежеподъемник закрыт, не превышают 2,2 м, и вследствие этого он подходит для грузовиков, контей- неров и т.д. Конструкция простая, стандартная, состо- ящая из тележки с подъемником под максимальную загрузку 2500 кг, которая хорошо испытана и надежна. Это - система выгрузки с двумя, идеально сбалансиро- ванными поршнями. Все устройство закреплено на станине с устойчивыми, фиксируемыми ножками, под- ходящими для дежеподъемника. Внутри установлена мощная гидравлическая система, предназначенная для непрерывной работы. Дополнительно к системам безопасности рабочая площадка дежеподъемника огорожена защитным поручнем, который закрывает место под дежой. По заказу можно огородить эту пло- щадку защитным барьером с дверью для предотвра- щения доступа в потенциально опасную зону. Макси- мальный вес подъема 800 кг.





## Panificazione Bakery



### “Sollevatori per Vasche Planetarie”

Planetary mixer Lifters



sollevatori  
Lifter

Modello Model	KW	Peso Weight (Kg)	Alimentazione Voltage	Altezza scarico Discharge (mm)	Portata Lifting capacity (Kg)	Dimensioni aperto Dimension opened (mm)	Dimensioni chiuso Dimension closed (mm)
SVP M1 (Manuale-Manual)	-	52	-	1500	100*	-	-
SVP 1	1,5	320	400/3/50	1500	150	1200X1250X2400	1280X1250X2150
SVP 2	1,5	360	400/3/50	2000	150	1200X1250X2800	1280X1250X2400

\* Vasca inclusa/Bowl included

#### CARATTERISTICHE TECNICHE GENERALI GENERAL TECHNICAL CHARACTERISTICS

##### SVP M1

- Struttura in acciaio elettrosaldato
- Sollevamento Manuale
- Altezza scarico Max 1500mm
- Basculamento laterale
- Portata max 100kg (compresa vasca)
- Montato su ruote piroettanti
- Freno di stazionamento

- Structure in electrowelded steel
- Manual Lifting
- Height of discharge max 1500mm
- Horizontally pivoting discharging system
- Lifting capacity max 100kg (Bowl included)
- Mounted on pivoting wheels
- Standing Brake

##### SVP 1 - SVP 2

- Struttura in acciaio elettrosaldato e colonna in acciaio inox
- Sollevamento mediante pistone idraulico e ribaltamento manuale con riduttore a vite senza fine per parzializzazione dello scarico
- Montato su ruote per facile traslazione
- Normative CE

- Structure in electrowelded steel and column in stainless steel
- Lifting with hydraulic piston and manual tilting with endless screw reducer for partial unloading
- Wheel mounted for easy movement
- CE rules

#### OPTIONALS

- Tensioni speciali
- Adattamento vasche altri produttori
- Special tensions
- Different bowls adjustment



Il sollevatore rovesciatore per vasche della linea PE si rende indispensabile per lo svuotamento del prodotto, quando questo non è prelevabile con altri mezzi come pompe ecc. È costituito da una robusta struttura carrellata con colonna in acciaio inossidabile, sistema idraulico di sollevamento e riduttore per il ribaltamento manuale in modo da consentire lo svuotamento totale o parziale secondo le esigenze dell'utilizzatore. È prodotto in due altezze standard con centralina oleodinamica trifase, ma su richiesta sono realizzabili altezze diverse e centralina in corrente continua (senza cavo di alimentazione) con conseguente batteria 12V.



Die HebeKippvorrichtung ist für Wannen der Linie PE für die Entnahme des Produkts unabdingbar, da dies nicht durch andere Hilfsmittel wie Pumpen etc. erfolgen kann. Sie besteht aus einer widerstandsfähigen Konstruktion mit Fahrwerk und Säule aus rostfreiem Stahl, hydraulischem Hubsystem und Untersetzungsgetriebe für das manuelle Kippen, wodurch die vollständige Entleerung sowie Entnahme von Teilmengen je nach Bedarf ermöglicht wird. Lieferbar in zwei Standardhöhe mit dreiphasiger Hydraulikeinheit, während auf Anfrage abweichende Höhen sowie eine Steuereinheit mit Gleichstrom (ohne Versorgungskabel) und somit Batterie von 12 V bestellt werden können.



The tilting lifter designed for the line PE tanks is essential to discharge the product, when it cannot be done using other means, such as pumps, etc. The lifter has a trolley-mounted, heavy duty structure with a stainless steel column, hydraulic lifting and reduction gearing system for manual tilting to enable total or partial discharge according to the user's needs. The lifter can be supplied in two standard heights with a three-phase hydraulic control unit, while different heights and a direct current control unit (without power cable) and subsequent 12V battery are available on request.



El elevador vertedor para cubas de la línea PE es indispensable para vaciar el producto, cuando este no se puede tomar con otros medios como bombas, etc. Está formado por una sólida estructura carrusel con columna de acero inoxidable, sistema hidráulico de elevación y reductor para el vuelco manual que permite vaciar por completo o de forma parcial según las exigencias del usuario. Se proporciona en dos alturas estándar con centralita oleodinámica trifásica, mientras que a pedido existen alturas diferentes y centralita de corriente continua (sin cable de alimentación) y con batería de 12V.



Le basculeur de cuves de la ligne PE est indispensable pour le vidage du produit quand il ne peut pas être prélevé par autres moyens comme pompes etc. Il s'agit d'une structure robuste avec une colonne en acier inoxydable, système hydraulique de soulèvement et réducteur pour le renversement manuel, pour permettre le vidage total ou partiel selon les besoins de l'utilisateur. Le basculeur est produit en deux hauteurs standard avec centrale oléodynamique triphasée. Il est possible de construire des basculeurs sur mesure et centrale en courant continu (sans câble d'alimentation) et batterie 12V.



Подъемник – опрокидыватель дежи PE является необходимым приспособлением для опорожнения продукта, если он не может забираться другими средствами, такими как насосы и т.д. Он состоит из прочной передвижной конструкции с колонной из нержавеющей стали, гидравлической подъемной системы и редуктора для ручного опрокидывания, обеспечивающего полное или частичное опорожнение, в зависимости от потребностей пользователя. Поставляется двух стандартных высот с трех- фазным гидравлическим блоком, в то время как, по заказу, выпускаются различные значения высоты и блок, работающий на постоянном токе (без кабеля питания) с соответствующей батареей 12В.



## Panificazione Bakery



### “Ribaltatori”

Tipper lifters



Tippers

Modello Model	KW	Peso Weight (Kg)	Alimentazione Voltage	Altezza scarico Discharge (mm)	Portata Lifting capacity (Kg)	Dimensioni aperto Dimension opened (mm)	Dimensioni chiuso Dimension closed (mm)
SINGLE TIPPER	2,2	480	400/3/50	1200	400	3050X1480X2100*	3050X1480X1160
DOUBLE TIPPER	2,2	650	400/3/50	1200	400	3050X1480X2100*	3050X1480X1160

\* L'ingombro varia a seconda della vasca utilizzata  
Dimensions depending on bowl

#### CARATTERISTICHE TECNICHE GENERALI GENERAL TECHNICAL CHARACTERISTICS

- Struttura in acciaio elettrosaldato
- Doppio sistema di ribaltamento basculante con pistoni indipendenti
- Piastra di appoggio a terra in acciaio inox
- Anello di protezione antinfortunistica
- Doppio comando destra-sinistra
- Centralina Idraulica esterna
- Normative CE
- Certificazione GOST
- Structure in electrowelded steel
- Horizontally pivoted tilting double system with independent pistons
- Support plate in stainless steel
- Safety protection ring
- Double control left and right
- Side hydraulic control board
- CE rules
- GOST certification

#### OPTIONALS

- Tensioni speciali
- Adattamento vasche altri produttori
- Scivolo teflonato
- Special tensions
- Different bowls adjustment
- Tefloned chute



SOLLEVATORI  
LIFTERS



Consiste in una struttura in lamiera di acciaio elettrosaldato appoggiata su una piastra inox che garantisce la sua stabilità. È provvisto di due ribaltatori idraulici che ruotano sullo stesso asse. Lo scopo è consentire il rovesciamento della pasta, proveniente da vasche carrellate di impastatrici mod. VE o RB, in vasche di riposo per la maturazione degli impasti o lieviti. Una volta completato il ciclo di maturazione per ottenere lieviti naturali, essi possono essere rovesciati a loro volta nelle vasche carrellate ed introdotti nelle impastatrici e con l'aggiunta di altra farina, acqua ed altro necessario, si può produrre l'impasto finale. Mediante il doppio ribaltatore l'impasto finito può essere ancora rovesciato nelle vasche di tipo sovietico per un eventuale ulteriore riposo prima dell'utilizzo finale.



Bestehend aus elektrisch geschweißtem Stahlblech, liegt die Konstruktion auf einer Platte aus rostfreiem Stahl auf, welche ihre Stabilität garantiert. Ausgestattet mit zwei hydraulischen Kippvorrichtungen, die um dieselbe Achse drehen. Aufgabe ist es, die Teigmasse von Knetmaschinenwannen mit Fahrwerk, Mod. VE oder RB, zur Reifung in die Ruhewanne um zu füllen. Ist der Reifezyklus für, z. B. Teig mit natürlicher Hefe, abgeschlossen, kann dieser wiederum in die Wanne mit Fahrwerk umgefüllt, danach in die Knetmaschine gegeben und durch Zugabe von weiterem Mehl, Wasser oder anderen Zutaten das Endprodukt zubereitet werden. Mithilfe der doppelten Kippvorrichtung kann die fertige Teigmasse noch einmal in die Ruhewanne (bereits in Kundenbesitz) für eine weitere Ruhephase vor dem Endgebrauch umgefüllt werden.



It is made of a structure in electro-welded steel sheet supported by a stainless steel plate that guarantees its stability. It is equipped with two hydraulic tipper rotating on the same axis. Its goal is tipping dough, coming from wheeled bowls of mixers mod. VE or RB, into rest bowls for the ripening of dough or yeasts. Once the ripening cycle for getting natural leavens is completed, they can be tipped in their turn into the wheeled bowls and put into the mixers and adding more flour, water and what else necessary, you can get the final dough. Thanks to the double tipper the finished dough can still be tipped in the soviet type bowls for a possible further rest before the final use.



Consiste de una estructura de chapa de acero electrosoldado apoyada sobre una plancha inoxidable que garantiza su estabilidad. Presenta dos volcadores hidráulicos que giran sobre el mismo eje. El objetivo es permitir el vuelco de la pasta, que proviene de las cubas de amasadoras mod. VE o RB, en cubas de reposo para la maduración de los amasijos o levaduras. Al completar el ciclo de maduración para obtener levaduras naturales, se pueden verter a su vez en las cubas y introducir en las amasadoras y con el agregado de otra harina, agua y otro ingrediente necesario, se puede producir el amasijo final. Con el volcador doble, el amasijo terminado se puede verter en las cubas de reposo de propiedad del cliente para un posterior reposo antes del uso final.



Il s'agit d'une structure en tôle d'acier électro-soudée et posée sur une plaque d'inox qui garantit sa stabilité. Il est pourvu de deux renverseurs hydrauliques qui tournent sur leurs propres axes. Le but est de permettre le renversement de la pâte, provenant des cuves sur roulettes des pétrins modèle VE et RB, dans les cuves de repos pour la maturation des pâtes et des levages. Une fois que le cycle est complété pour obtenir les levages naturels, ils peuvent être placés dans les cuves sur roulettes et introduits dans les pétrins et en ajoutant de la farine, de l'eau ou autre on peut produire la pâte finale. Grâce au double renverseur, la pâte finie peut être encore placée dans les cuves de type soviétique pour un ultérieur repos avant l'utilisation finale.



Конструкция изготовлена из электропаяного стального листа, усиленного пластиной из нержавеющей стали, что гарантирует устойчивость. Она оснащена двумя гидравлическими опрокидывателями, вращающимися на одной оси. Целью является перевалка теста из подкатных деж для тестомесильных машин мод. VE или RB в свободные дежи советского периода для расстойки теста или дрожжей. Когда цикл созревания натуральной закваски завершен, содержимое можно перегрузить в подкатные дежи на колесах, поставить их в тестомесильные машины и замесить тесто, добавив муки, воды и всего необходимого. Благодаря использованию двустороннего опрокидывателя, замешанное тесто можно опять перегрузить в дежи советского периода для хранения содержимого вплоть до его использования.



## Panificazione Bakery



### “Tramogge”

Tramogge di alimentazione  
Feeding Hoppers



Modello Model	KW	Peso Weight (Kg)	Alimentazione Voltage	Capacità tramoggia Hopper Capacity (Lt)	Dimensioni pezzi Pieces dimension (mm)	Dimensioni Dimension (mm)
<b>TRAMOGGE CON TAGLIO A STELLA/STARS CUTTING FEEDING HOPPERS</b>						
TR 350	1,5	310	400/3/50	350	300X350	1240X1240X2600
TR 400	1,5	320	400/3/50	400	300X400	1240X1240X2600
TR 500	1,5	340	400/3/50	500	300X500	1240X1240X2600
<b>TRAMOGGE CON TAGLIO A GHIGLIOTTINA/GUILLOTINE CUTTING FEEDING HOPPERS</b>						
TR 350G	-	210	-	350	-	1240X1240X2600
TR 400G	-	220	-	400	-	1240X1240X2600
TR 500G	-	240	-	500	-	1240X1240X2600
<b>TRAMOGGE CON SBRICIOLATORE/FEEDING HOPPERS WITH CRUMBLER</b>						
TR 350SB	4,5	450	400/3/50	350	A richiesta On request	1240X1240X2600
TR 400SB	4,5	460	400/3/50	400		1240X1240X2600
TR 500SB	5,7	500	400/3/50	500		1240X1240X2600

## TRAMOGGE SPECIALI SPECIAL FEEDING HOPPERS



Tramoggia con postazione di lavaggio  
Feeding hopper with cleaning position



Tramoggia traslante per alimentare più linee  
Traslating feeding hopper for multiple lines

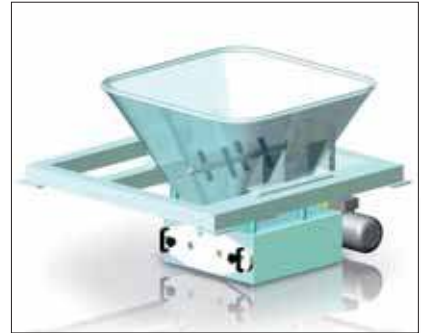

Tramoggia con aspi per paste dure  
Feeding hopper with rotating reels for hard dough



Tramoggia con sbriciolatore  
Feeding hopper with crumbler



Tramogge multiple con tappeti  
Multiple feeding hoppers with belts



Tramoggia con taglio a ghigliottina  
Guillotine feeding hopper



### CARATTERISTICHE TECNICHE GENERALI GENERAL TECHNICAL CHARACTERISTICS

- Tramoggia in acciaio inox
- Parti a contatto inox o polietilene
- Grande facilità di smontaggio parti interne per pulizia
- Programmatore n. di pezzi da scaricare
- Sensori per funzionamento automatico
- Normative CE
- Certificazione GOST

- Stainless steel feeding hopper
- Contact parts in stainless steel or polyethylene
- Internal parts easy to disassemble for cleaning
- Programmer of pieces to be discharged
- Sensors for automatic working
- CE rules
- GOST certification

### OPTIONALS

- Sistema di lubrificazione elementi di tranciatura
- Sistema di nebulizzazione olio nella tramoggia
- Traslazione della tramoggia
- Aspi per paste dure
- Pannello di comando con PLC
- Piattaforme d'ispezione fisse o mobili
- Teflon interno tramoggia
- Telaio in acciaio inox

- Internal parts lubrication system
- Hopper oil nebulization system
- Translatin hopper
- Rotating reels for hard dough
- PLC control panel
- Fixed or removable inspection platforms
- Teflon
- Stainless steel frame



Tramoggia bassa  
Low feeding hopper



Gruppo taglio tramoggia con sbriciolatore  
Crumbler with feeding hopper cutting group



Tramoggia con sbriciolatore traslante  
Translating feeding hopper with crumbler



Particolare tramoggia traslante  
Translating feeding hopper



Le tramogge di alimentazione sono in grado di fornire alle spezzatrici sottostanti, blocchi di pasta sia attraverso un sistema a lobi triangolari (di quantità variabile a seconda del tipo e della lunghezza dei lobi utilizzati) sia con un sistema di taglio a ghigliottina.

La macchina è fornita di due sensori di profondità; il primo indica se la spezzatrice sottostante ha bisogno di pasta; il secondo posto alla sommità della tramoggia e indica con un segnale luminoso quando si sta per svuotare.

Un telaio in acciaio sostiene la macchina all'altezza scelta, a richiesta può essere montata su sistemi traslanti per l'alimentazione di più linee o per avere una posizione libera per la pulizia.

Sono previsti alcuni optional come: la teflonatura della tramoggia, un sistema di lubrificazione dei lobi triangolari e un sistema di nebulizzazione olio nella tramoggia, particolarmente adatti per paste tenere e appiccicose come anche versioni speciali per impasti semiseccchi o granulosi. A richiesta può essere integrata con uno sbriciolatore, molto interessante per le produzioni di biscotti.

Particolare cura è stata posta nella scelta dei materiali, le parti a contatto con la pasta in acciaio inox e in Polietilene alimentare, facilmente smontabili per pulizia e lavaggio.



Die Ladetrichter sind fähig Teigstücke oder mit einem System von dreieckigen Kappen ( in unbeständiger Menge nach dem Typ und der Länge der benützen Kappen) oder mit einem System von Guillotinetteil in die darunter liegendenTeigteilmaschine zu liefern .

Die Maschine ist mit zwei Tieffühlern gerüstet. Der Erste zeigt an dass die untergelegte Teigteilmaschine Teig braucht; der auf dem Gipfel des Ladetrichters gelegte zweite Fühler zeigt mit einem leuchtendem Signal an wenn der Trichter leer ist.

Ein Gerüst aus rostfreiem Stahl stützt die Maschine an der gewünschten Höhe; auf Wunsch kann sie auf translatorischen Systeme montiert werden für die Zuführung von verschiedenen Linien oder um eine für die Reinigung freie Lage zu haben.

Die folgenden Extras sind zur Verfügung: Mit Teflon innen beschichteter Trichter, Schmiersystem der dreieckigen Kappen, Sprinklersystem in demTrichter besonders geeignet für weiche und klebrige Teige oder für halbtrockene oder kornigeTeige .

Auf Wunsch kann der Trichter mit einem Abbröckeler ausgerüstet sein, was sehr nützlich für die Produktion von Keksen ist.

Die Materialien sind sorgfältig ausgewählt worden. DieTeile in Kontakt mit demTeig sind aus PE oder rostfreiem Stahl und alles kann für die Reinigung leicht abmontiert werden.



The feeding hoppers are able to provide to the dividers below blocks of dough through a system of triangular lobes (portions of dough variable in weight, according to the type and length of the lobes used) or through a guillotine cutting system.

This machine is equipped with two depth sensors: the first shows if the divider below needs dough; the second one placed at the top of the hopper indicates through a light when the hopper is almost empty.

A frame, made of steel elements, supports the machine at the wished height and, at request, it can be mounted on translating systems for feeding more lines or for having a free position for cleaning.

Some options are available as: hopper covered with Teflon inside, lubrication system of the triangular lobes, an oil nebulization system of the hopper (suitable for sticky and soft dough) as well as special versions for half-dry or granulose mixtures. On demand the feeding hopper can be integrated with a crumbler, very interesting for the production of cookies.

Particular care has been taken in choosing the materials, the parts in contact with the dough are in PE or stainless steel, easily disassembled for normal cleaning and washing.



Las tolvas de alimentacion pueden proveer a las cortadoras bloques de masa a través de un un sistema a lobulos traingulares (que rodeando provee piezas de masa con peso variable, segun la largura y el tipo de los lobulos).

Un chasis en acero sostiene la maquina a la altura deseada y a pedido puede ser montada su un sistema traslante por la alimentacion de mas lineas o por tener una posición libre para la limpieza.

El aparato electrico se completa con dos sensores de profundidad: el primero indica si la cortadora necesita masa, el segundo, puesto el la sumidad de la tolva de alimentacion, indica cuando esta ultima esta a punto de vaciarse y manda una senal luminosa.

Se preveen algunos opcionals como: tolva teflonada internamente, sistema de lubrificacion de los lobulos traingulares, sistema de nebulizacion aceite en tolva particularmente adecuado para masas tiernas o pegajosas, así como versiones especiales por masas semi-secas, o granulosas.

Peculiar atencion ha sido puesta en la eleccion de los materiales, las partes en contacto con la masa son de PE o inox, el todo facilmente desmontable para la normal limpiadura y lavado.



Les trémies d'alimentation sont capables de fournir aux diviseurs sous-jacents, des blocs de pâte par un système à lobes triangulaires (quantité variable selon le type et la longueur des lobes utilisée) ou avec un système de coupe à guillotine.

La machine est équipée de deux capteurs de profondeur ; le premier indique si la diviseuse sous-jacente a besoin de la pâte ; la deuxième placé au somme de la trémie et indique le vide de celle-ci par un signal lumineux .

Un cadre en acier soutient la machine à la hauteur désirée , à la demande peut être monté sur un système de translation pour l'alimentation de plusieurs lignes ou pour obtenir une position libre pour le nettoyage.

Quelques options sont prévues comme: le revêtement en teflon de la trémie, un système de lubrification des lobes triangulaires et une huile de brumisation dans la trémie, particulièrement adapté pour des pâtes molles et collantes ainsi que des versions particulières pour pâte granulaire ou semi- sèche. A la demande peut être intégré avec un déliteur, très intéressant pour la production de biscuits

Le choix des matériaux a été particulièrement soigné, les parties en contact avec la pâte sont en acier inoxydable et en PE, facilement démontables pour le nettoyage et le lavage .



Загрузочные воронки позволяют выгружать в стоящий внизу делитель блоки теста как через систему треугольных пластин (разного количества, благодаря пластинам разной длины и тесту разного вида), так и через систему нарезки гильотина.

Электрооборудование снабжено двумя датчиками глубины, первый показывает если надо добавить дополнительное количество теста в делитель. Второй, установленный сверху загрузочной воронки, показывает подачей сигнала, когда воронка становится почти пустой.

Корпус воронки из нержавеющей стали поддерживает машину на выбранной высоте и, по заявке, может быть установлена на транспортирующие системы для подачи продукта на несколько линий или для выгрузки продукта при чистке оборудования.

Имеются следующие опции: воронка, покрытая тефлоном; система смазки треугольных пластин; система распыления масла в воронке, особо подходящие для жидкого или липкого теста. Существуют также специальные загрузочные воронки для полусухих или гранулированных смесей, которые по заявке могут быть интегрированы с системой окрошки, предназначенные в основном для производства печенья.

Особое внимание было уделено подбору материалов для деталей, контактирующих с тестом, они изготовлены из полиуретана или нерж. стали. Их можно легко снять для обычной чистки и мойки.





## Panificazione Bakery



### “Spezzatrici Volumetriche”

Spezzatrici volumetriche  
Volumetric Dividers



Modello Model	KW	Peso Weight (Kg)	Alimentazione Voltage	Dimensioni Dimension (mm)
VOLUMETRIC DIVIDER	1,5	595	400/3/50	755X1600X1350
VOLUMETRIC DIVIDER + R (con arrotondatore/with rounder)	1,5	609	400/3/50	755X1600X1350

#### CARATTERISTICHE TECNICHE GENERALI GENERAL TECHNICAL CHARACTERISTICS

- Sistema a pistone aspirante a doppia camme
- Spezzatura delicata senza compressione
- Lubrificazione a circuito chiuso
- Variatore di velocità
- Produzione 1000÷2400 pezzi/ora
- Tramoggia standard kg 40
- Pistone Ø mm 90 pezzatura gr 30-400
- Pistone Ø mm 110 pezzatura gr 50-600
- Pistone Ø mm 120 pezzatura gr 80-950
- Pistone Ø mm 135 pezzatura gr 140-1300
- Suction piston system with double cam
- Soft dividing without compression
- Close circuit lubrication
- Speed variator
- Production 1000÷2400 PCS/HR
- Standard hopper kg 40
- Piston Ø mm 90 from gr 30 to 400
- Piston Ø mm 110 from gr 50 to 600
- Piston Ø mm 120 from gr 80 to 950
- Piston Ø mm 135 from gr 140 to 1300

#### OPTIONALS

- Tensioni Speciali
- Tramoggia Speciale (80-160-200 Lt.)
- Versione in Acciaio Inox
- Controllo velocità con Inverter
- Special tensions
- Special Hoppers (80-160-200 Lt.)
- Stainless Steel Version
- Inverter Speeds Controls



La spezzatrice ad aspirazione che presentiamo è una macchina di elevate prestazioni, garantite da una meccanica accurata e robusta. Il principio di spezzatura si basa sulla sola aspirazione della pasta in modo da garantire il minor maltrattamento dell'impasto durante la lavorazione e una buona costanza e precisione del peso. Il miglior rendimento della macchina si ottiene in presenza di impasti molli (60% di acqua e più), dove la delicatezza delle operazioni è essenziale per garantire la buona riuscita del pane. Sono attualmente disponibili 4 modelli standard per pezzature da 30 gr. a 1200 gr.; mentre a richiesta sono disponibili spezzatrici con due pistoni.

Un variatore continuo di velocità permette di adattare la produzione oraria alle singole esigenze dell'utilizzatore garantendo un massimo di circa 2000 pezzi/ora.

La macchina è provvista di ruote per facilitarne l'eventuale rimozione per la pulizia del locale. Viene normalmente dotata di una tramoggia di acciaio inossidabile che contiene all'incirca 40 kg di impasto, sono comunque disponibili tramogge di maggior capacità per consentire l'uso della macchina in impianti a produzione continua. Nel modello spezzatrice-arrotondatrice viene fornito un tappeto speciale con barra trasversale in teflon che consente una buona arrotondatura dei pezzi.



The suction divider presented here is a machine providing top performance, guaranteed by accurate sturdy mechanical technology. The dividing principle is exclusively based on dough suction, in order to ensure minimum dough ill-treatment during processing and a constant precise weight. The machine shows its best efficiency when processing soft dough mixes (60% water or more), where delicate operations are essential to obtain good bread-making results. 4 standard models are currently available for portions of 30 to 1200 g., while two-piston dividers are available on request. A stepless speed change gear allows the hourly production to be adapted to individual user's requirements, guaranteeing up to about 2000 pieces/hour.

The moderate overall machine dimensions make it possible to fully exploit the space available in the bakery; the machine is provided with wheels, which means it can be easily moved around when cleaning the room. It is usually provided with a stainless steel hopper having a capacity of 40 kg of dough mix, however larger hoppers are available to allow the machine to be used within continuous production plants. Easy operation, high reliability, sturdy structure and accurate finish undoubtedly make it one of the safest machines available on the market today. The divider-rounder model is supplied with a special belt having a transversal Teflon bar, which allows the pieces to be well rounded.



La diviseuse à aspiration que nous présentons est une machine à prestations élevées garanties par une mécanique soignée et solide. Le principe de découpage se base uniquement sur l'aspiration de la pâte afin d'abîmer le moins possible le mélange durant l'usinage et de garantir une bonne constance et précision du poids. Le meilleur rendement de la machine s'obtient en présence de mélanges mous (60% d'eau et plus) où la délicatesse des opérations est essentielle pour garantir la réussite du pain. Sont actuellement disponibles 4 modèles standards pour des découpes de 30 gr. à 1200 gr. alors que sur demande sont disponibles des diviseuses avec deux pistons.

Un variateur continu de vitesse permet d'adapter la production horaire aux simples exigences de l'utilisateur en garantissant un maximum de 2000 pièces environ! Maintenant, la machine est équipée de roues pour faciliter son enlèvement en cas de nettoyage du local. Elle est normalement équipée d'une trémie en acier inoxydable qui contient environ 40 kg de mélange, des trémies d'une capacité supérieure sont de toute façon disponibles pour permettre d'utiliser la machine dans des installations à production continue. Le modèle de la diviseuse-bouleuse est équipé d'un tapis spécial avec une barre transversale en téflon qui permet un bon arrondissement des morceaux.



Diese Teilmaschine mit Saugvorrichtung ist eine Maschine mit hoher Leistung, die durch eine sorgfältige und solide Mechanik gewährleistet wird. Das Teilprinzip besteht in der Absaugung vom Teig, damit er während der Bearbeitung am wenigstens strapaziert wird und erlaubt eine hohe Genauigkeit des gewünschten Gewichts. Die beste Leistung der Maschine erhält man bei weichen Teigsorten (60% Wasser oder mehr), wo die Zartheit der Bearbeitung für einen guten Erfolg wesentlich ist. Zur Zeit bieten wir 4 Standardmodelle an, und zwar für Teigstücke von 30 gr. bis 1200



gr.; gegen Anfrage sind auch Teilmaschinen mit zwei Kolben erhältlich. Ein stufenloser Drehzahlwandler erlaubt es, die Stundenproduktion den spezifischen Erfordernissen des Anwenders anzupassen und garantiert somit eine Produktion von ca. 200 Stücken pro Stunde.

Die reduzierten Aussemasse der Maschine erlauben die Installation auch in engen Räumen; die Maschine ist mit Rädern versehen, die deren Entfernung für Reinigungsarbeiten erleichtern. Sie montiert normalerweise einen Trichter aus rostfreiem Stahl mit einer Kapazität von ca. 40 Kg. Teig. Gegen Anfrage sind auf jeden Fall grössere Trichter erhältlich, die deren Anwendung in Fertigungslinien erlauben. Der einfache Betrieb und die hohe Zuverlässigkeit, sowie die solide Struktur setzen diese Maschinen unter den sichersten heute auf dem Markt.

In der Ausführung als Teil- und Rundmaschine wird auch einen speziellen Teppich mit Querstange aus Teflon geliefert, der eine einwandfreie Rundung der Teile erlaubt.

La pesadora de aspiración que presentamos es una máquina de elevadas prestaciones, garantizadas por una mecánica esmerada y robusta. El principio de división se basa sobre la sola aspiración de la masa en forma de garantizar el menor maltratamiento del amasado durante la elaboración y una buena constancia y precisión del peso. El mejor rendimiento de la máquina se obtiene en presencia de amasados mojados (60% de agua y más), donde la delicadeza de las operaciones es esencial para garantizar el buen resultado del pan. Son actualmente disponibles 4 modelos estándar para bolas de masa de 30 gr. a 1200 gr.; mientras que a demanda son disponibles divisoras con dos pistones.

Un variador continuo de velocidad permite adaptar la producción horaria según las necesidades del utilizador, garantizando un máximo de unas 2000 bolas de masa p/hora. Las reducidas dimensiones de la máquina permiten aprovechar al máximo los espacios en la panadería; la máquina está provista con ruedas para facilitar su eventual desplazamiento para la limpieza del local.

Vien normalmente equipada con una tolva de acero inoxidable que contiene aproximadamente 40 kg. de amasado, de todas maneras son disponibles tolvas con mayor capacidad para permitir el uso de la máquina en instalaciones de producción continua. La sencillez de funcionamiento, la alta confiabilidad de la máquina, la robustez de la estructura y el esmerado acabado, la coloca ciertamente entre las máquinas más seguras en la actualidad disponibles en el mercado.

En el modelo divisora-redondeadora se suministra un filtro especial con barra transversal de teflón que permite un buen redondeado de las bolas de masa.



Представленный здесь всасывающий делитель является машиной высокого уровня и его надежность гарантирована точной прочной механикой.

Принцип деления основан исключительно на всасывании теста, чтобы обеспечить минимальное разрушение структуры теста во время процесса деления и соблюсти весовую точность деления.

Эта машина показывает наилучшую эффективность при работе с мягким тестом (60% воды или более), когда точные операции являются необходимыми для получения хороших результатов в хлебопечении. В настоящее время разработаны четыре стандартные модели для деления теста на куски весом от 30 до 1200 г, а двухпоршневые делители предлагаются по запросу.

Бесшаговый механизм переключения скорости позволяет регулировать производительность и приспособить ее к индивидуальным требованиям пользователя, гарантируя ее до уровня 2000 шт/час. Умеренные габариты машины дают возможность использовать ее на имеющихся в пекарне площадях.

Машина оснащена колесами, которые позволяют быстро передвинуть ее при уборке помещения. Обычно машина поставляется вместе с загрузочной воронкой из нержавеющей стали вместимостью на 40 кг теста. Однако имеются воронки большего объема, что позволяет использовать машину на предприятиях с непрерывным производственным процессом.

Простая в эксплуатации, очень надежная и прочная конструкция и аккуратная отделка без сомнения делают эту машину одной из самых безопасных на рынке сегодня.

Модель делителя-округлителя оснащена специальной лентой с поперечной тефлоновой планкой для хорошего округления тестозаготовок.





## Panificazione Bakery



### “Arrotondatrici Coniche”

Arrotondatrici coniche  
Conical Rounders



Modello Model	KW	Peso Weight (Kg)	Alimentazione Voltage	Pezzi Pieces (gr. Min/Max)	Dimensioni Dimension (mm)
CONICAL T1	0,8/1,5	310	400/3/50	150÷2000	900x900x1400
CONICAL T2	0,8/1,5	310	400/3/50	300÷3900	900x900x1400
DOUBLE CONICAL T1	0,8/1,5	600	400/3/50	150÷2000	1300X1000X1700
DOUBLE CONICAL T2	0,8/1,5	600	400/3/50	300÷3900	1300X1000X1700

#### CARATTERISTICHE TECNICHE GENERALI GENERAL TECHNICAL CHARACTERISTICS

- Struttura in acciaio elettrosaldato, zincato e verniciata
- Testata in fusione di alluminio
- Coltelli acciaio inox
- Piatto in polietilene alimentare
- Normative CE
- Painted galvanized and electro-welded steel structure
- Aluminium cast head
- Stainless steel knives
- Food-safe polyethylene plate
- CE rules

#### OPTIONALS

- Tappeto di uscita 600 mm
- Soffiatore Aria Calda e fredda con termostato regolabile
- Rivestimento in acciaio inox
- Exit conveyor belt 600 mm length
- Warm and Cold air adjustable thermostat
- Stainless Steel Cover



Le arrotondatrici SIGMA, dotate delle migliori garanzie di sicurezza, affidabilità e durata, garantiscono un perfetto arrotolamento di pagnotte di varie pezzature anche con impasti morbidi, senza alterarli o maltrattarli. Tutte le arrotondatrici sono dotate di canali in alluminio con rivestimento antiaderente, sfarinatore regolabile e cono rotante trattato con nichel atossico o teflon.

Sigma propone vari modelli di arrotondatrici:

- l'arrotondatrice CONICA T1 per pezzature dai 100/150 gr fino ai 2000 gr.
- l'arrotondatrice CONICA T2 per pezzature dai 300 gr fino ai 3900 gr.
- l'arrotondatrice BICONICA T1 per pezzature dai 100/150 gr fino ai 2000 gr.
- l'arrotondatrice BICONICA T2 per pezzature dai 300 gr fino ai 3900 gr.

Quest'ultima possiede tutte le caratteristiche di una arrotondatrice ad un solo cono, anche lo spazio occupato rimane lo stesso, ma proprio perché biconica raddoppia le proprie prestazioni, eliminando il doppio arrotondamento manuale. Con un particolare accorgimento dei due nastri trasportatori il pastone ha sempre la chiusura nella parte bassa all'entrata del secondo cono. A richiesta possono essere fornite con canali soffiatori di aria calda e fredda con termostato regolabile, il tappeto in uscita ed il rivestimento della macchina in acciaio inox. Le arrotondatrici SIGMA sono conformi alle Direttive Comunitarie in termini di sicurezza ed igiene.



SIGMA rounder machines, endowed with the best safety, reliability and durability guarantee, ensure perfect rolling of bread rolls of different formats, even in case of soft dough, without altering or distorting the final shape. All the rounder machines are equipped with aluminium channels with non-stick coating, adjustable flour duster and rotating cone treated with non-toxic nickel or Teflon.

Sigma offers different rounder machine models:

- CONICAL rounder machine T1 for pieces from 100/150 gr to 2000 gr.
- CONICAL rounder machine T2 for pieces from 300 gr to 3900 gr.
- DOUBLE-CONE rounder machine T1 for pieces from 100/150 gr to 2000 gr.
- DOUBLE-CONE rounder machine T2 for pieces from 300 gr to 3900 gr.

The latter has the same characteristics of a single-cone machine, even the overall dimensions, but its productivity is doubled because the process does not require any further manual handling. A special arrangement of the two conveyor belts causes the seal of dough to face down when entering in the second cone. Upon request, the machines can be equipped with cold and hot air blowing channels with adjustable thermostat, exit conveyor belt and machine stainless steel coating. SIGMA rounder machines comply with EU directives on safety and hygiene.



Les arrondisseuses SIGMA, dotées des meilleures garanties de sécurité, fiabilité et durée, assurent un enroulement parfait de miches de différents calibres également avec des pâtes souples, sans les altérer ou les maltraiter. Toutes les arrondisseuses sont équipées de canaux en aluminium et présentent un revêtement anti-adhérent, un saupoudroir à farine réglable et un cône pivotant traité avec du nickel atoxique ou téflon.

Sigma propose différents modèles d'arrondisseuses :

- l'arrondisseuse CONIQUE T1 pour calibres allant de 100/150 g à 2 000 g.
- l'arrondisseuse CONIQUE T2 pour calibres allant de 300 g à 3 900 g.
- l'arrondisseuse BICONIQUE T1 pour calibres allant de 100/150 g à 2 000 g.
- l'arrondisseuse BICONIQUE T2 pour calibres allant de 300 g à 3 900 g.

Cette dernière possède toutes les caractéristiques d'une arrondisseuse ayant un seul cône et l'espace occupé reste également le même, mais étant donné qu'elle est biconique, elle double ses prestations, en supprimant le double arrondissement manuel. Grâce à une attention particulière des deux convoyeurs, la pâtée présente toujours la fermeture dans la partie inférieure à l'entrée du deuxième cône. Sur demande, elles peuvent être fournies avec des canaux souffleurs d'air chaud et froid avec thermostat réglable, tapis sortant et revêtement de la machine en acier inox. Les arrondisseuses SIGMA sont conformes aux Directives Communautaires en matière de sécurité et hygiène.



Die SIGMA Rundwirker gewähren die größtmögliche Sicherheit, Zuverlässigkeit und Lebensdauer, ein perfektes Runden des Brotlaibs verschiedener Größen, auch mit weichen Teigmassen, ohne sie zu verändern oder schlecht zu behandeln. Alle Rundwirker sind mit antihafbeschichteten Aluminiumkanälen, verstellbarem Bemehler und mit einem Drehkegel, der mit giftfreiem Nickel oder Teflon behandelt wurde.

Sigma bietet verschiedene Modelle von Rundwirker an:

- Rundwirker CONICA T1 für Stückgrößen von 100/150 gr bis 2000 gr.
- Rundwirker CONICA T2 für Stückgrößen von 300 gr bis 3900 gr.
- Rundwirker BICONICA T1 für Stückgrößen von 100/150 gr bis 2000 gr.
- Rundwirker BICONICA T2 für Stückgröße von 300 gr bis 3900 gr.

Letzterer hat alle Eigenschaften eines Rundwirkers mit einem einzigen Kegel. auch der beanspruchte Raum bleibt derselbe, aber aufgrund der beiden Kegel verdoppelt er seine Leistung und macht das doppelte manuelle Runden überflüssig. Durch einen besonderen Kunstgriff der beiden Förderbänder liegt der Teigabschluss im unteren Teil am Eingang des zweiten Kegels. Auf Anforderung können diese mit Warm- und Kaltluftblaskanälen und regelbarem Thermostat, einer Matte im Ausgang und einer Maschinenverkleidung in Edelstahl geliefert werden. Die SIGMA Rundwirker entsprechen den EG-Richtlinien betreffend Sicherheit und Hygiene.



Las redondeadoras SIGMA, equipadas con las mejores garantías de seguridad, fiabilidad y duración, aseguran un redondeado perfecto de panes de varios tamaños incluso con masas blandas, sin alterarlas o maltratarlas. Todas las redondeadoras cuentan con canales de aluminio con revestimiento antiadherente, enharinador regulable y cono rotatorio tratado con níquel atóxico o teflón.

Sigma propone varios modelos de redondeadoras:

- La redondeadora CONICA T1 para tamaños desde 100/150 g hasta 2000 g.
- La redondeadora CONICA T2 para tamaños desde 300 g hasta 3900 g.
- La redondeadora BICONICA T1 para tamaños desde 100/150 g hasta 2000 g.

La redondeadora BICONICA T2 para tamaños desde 300 g hasta 3900 g. Esta última posee todas las características de una redondeadora con un solo cono, incluso el espacio ocupado sigue siendo el mismo, pero por ser bicónica duplica los propios rendimientos, eliminando el doble redondeado manual. Con un pequeño detalle de las dos cintas transportadoras la masa se cierra siempre en la parte baja en la entrada del segundo cono. A petición se pueden suministrar con canales de soplado de aire caliente y frío con termostato regulable, la cinta en salida y el revestimiento de la máquina en acero inoxidable. Las redondeadoras SIGMA cumplen con las Directivas Comunitarias sobre seguridad e higiene.



Округлители Сигма, оснащенные наилучшими гарантиями безопасности, надежности и долговечности, обеспечивают идеальное округление заготовок различных размеров даже из мягкой тесто не изменяя их форму и структуру.

Все округлители оснащены каналами из алюминия с антипригарным покрытием, регулируемой мукоподсыпкой и вращающимся конусом обработанным нетоксичным никелем или тефлоном.

Сигма предлагает различные модели округлителей:

- Округлитель КОНУСНЫЙ Т1 для заготовок от 100 / 150 гр до 2000 гр.
- Округлитель КОНУСНЫЙ Т2 для заготовок от 300 гр до 3900 гр.
- Округлитель ДВУХКОНУСНЫЙ Т1 для заготовок от 100 / 150гр до 2000 гр.

Округлитель ДВУХКОНУСНЫЙ Т2 для заготовок от 300 гр до 3900гр. Двухконусный округлитель обладает всеми характеристиками одноконусного, также занимаемое им пространство остается тем же, но только потому что двухконусный, удваивает свою производительность, избавляя от последующего ручного округления. С конкретным расположением двух конвейерных лент масса теста всегда заканчивается в нижней части при входе во второй конус. По запросу машины могут быть снабжены каналами воздуходувки горячего и холодного воздуха с регулируемым термостатом, лентой при выходе готовых заготовок из машины и покрытия из нержавеющей стали. Округлители Сигма соответствуют директивам ЕС с точки зрения безопасности и гигиены.





## Panificazione Bakery



### “Spezzarrotondatrici”

Bun Dividers



Modello Model	Descrizione Description	KW	Peso Weight (Kg)	Alimentazione Voltage	N. divisioni Pieces nr.	Pezzi Pieces (gr. Min/Max)	Dimensioni Dimension (mm)
SPM 15					15	100÷260	
SPM 22	Spezzarrotondatrice Semiautomatica				22	50÷180	
SPM 30	Semi automatic bun divider	0,5	175	400/3/50	30	40÷135	680x660x1470
SPM 30 P					30	25÷90	
SPM 36					36	34÷110	
SP 3/4 A 15					15	100÷260	
SP 3/4 A 22	Spezzarrotondatrice 3/4 automatica				22	50÷180	
SP 3/4 A 30	3/4 automatic bun divider	1,3	205	400/3/50	30	40÷135	680x660x1470
SP 3/4 A 30 P					30	25÷90	
SP 3/4 A 36					36	34÷110	
SPA 15					15	100÷260	
SPA 22	Spezzarrotondatrice automatica				22	50÷180	
SPA 30	Automatic bun divider	1,3	205	400/3/50	30	40÷135	680x660x1470
SPA 30 P					30	25÷90	
SPA 36					36	34÷110	

#### CARATTERISTICHE TECNICHE GENERALI GENERAL TECHNICAL CHARACTERISTICS

- Struttura in acciaio elettrosaldato, zincato e verniciato
- Testata in fusione di alluminio
- Coltelli acciaio inox
- Piatto in polietilene alimentare
- Normative CE
- Certificazioni ETL, CSA
- Painted galvanized and electro-welded steel structure
- Aluminium cast head
- Stainless steel knives
- Food-safe polyethylene plate
- CE rules
- ETL, CSA certified

#### OPTIONALS

- Tensioni Speciali
- Special tensions



Le spezzatrici arrotondatrici SPA (automatiche) e SPM (semiautomatiche) utilizzano un sistema di arrotondatura che replica perfettamente il movimento della mano, quindi in modo perfetto e delicato.

Le caratteristiche generali sono:

- Testata in fusione
- Coltelli in acciaio inox
- Struttura in lamiera d'acciaio elettrosaldata
- Piatti in policarbonato
- Regolazione della corsa in funzione della pezzatura
- Testa e anello divisore facilmente smontabile per una facile pulizia.

Le macchine modello SPM (semiautomatiche) hanno le funzioni abbassamento testa, pressature e taglio manuali mediante leve, mentre l'arrotondatura è automatica, con comando a mano, mentre le macchine modello SPA (automatiche) hanno la pressata ed il taglio servocomandate da pistone idraulico e l'arrotondatura automatica in unico ciclo. Tutte le macchine sono montate su ruote con piedini antivibranti.



Diese Spezialmaschinen SPA (automatisch) und SPM (halbautomatisch) benutzen ein System der Rundung, das die Handbewegung sehr gut imitiert und deswegen ist sie perfekt und sehr harmonisch.

Beschaffenheit der Maschine:

- Zylinderkopffusion
- Messer in Edelstahl
- Elektrogeschweißte Stahlstruktur
- Teller in Polykarbonat
- Einstellbare Stückzahl
- Leicht abnehmbare Teile für die Reinigung

Die Modelle SPM (halbautomatisch) haben durch Hebelvorrichtungen manuellbetriebene Funktionen für das Senken des Kopfteils, der Pressung und der Zerstückelung. Bei den Modellen SPA (automatisch) wird die Pressung, die Zerstückelung sowie die Rundung mit Hilfe hydraulisch gesteuerter Kolben in einem einzigen Arbeitsgang durchgeführt. Alle Maschinen sind auf schwingungsdämpfenden Kugelrädern aufgebaut.



Bun dividers SA (automatic) and SPM (semiautomatic) use a rounding system that perfectly and softly reproduces a hand movement.

The general features are:

- Steel casting head
- Stainless steel knives
- Structure of electrowelded steel sheet
- Plates in polycarbonate
- Stroke regulation in accordance to the size
- Head and dividing ring can be easily disassembled to be cleaned.

In Model SPM machines (semiautomatic), the head lowering, the pressings and the cutting are through levers, while the rounding is automatic with manual control. In Model SPA machines (automatic) the pressing and cutting are servocontrolled by a hydraulic ram and automatic rounding in a single cycle. All machines are installed on wheels with antivibrating feet.



Las partidoras redondeadoras SPA (automáticas) y SPM (semiautomáticas) utilizan un sistema de redondeo que replica perfectamente el movimiento de la mano, de modo perfecto y delicado.

Las características generales son las siguientes:

- Cabezal en fusión
- Cuchillas de acero inoxidable
- Estructura de chapa de acero electrosoldada
- Platos de policarbonato
- Regulación de la carrera en función del tamaño
- Cabezal y anillo divisor fácil de desmontar para facilitar la limpieza

Las máquinas modelo SPM (semiautomáticas) tienen las funciones de bajar el cabezal, presar y cortar de forma manual con palancas, mientras que el redondeo es automático, con mando en mano. Las máquinas modelo SPA (automáticas) presentan prensado y corte servocomandados por un pistón hidráulico y el redondeo automático en un solo ciclo. Las máquinas se montan sobre ruedas con pies antivibratorios.



Les diviseuses-bouleuses SPA (automatiques) et SPM (semi automatiques) utilisent un système d'arrondissement qui réplique le mouvement de la main de l'homme de façon parfaite et délicate.

Les caractéristiques générales sont:

- Tête en fusion
- Couteaux en acier inox
- Structure en tôle d'acier électro-soudée
- Plateaux en poly carbone
- Réglage de la course en fonction de la taille
- Tête et anneau diviseur facilement démontable pour un nettoyage facile.

Les machines SPM (semi automatiques) ont les fonctions d'abaissement de la tête, pressage et coupe manuels grâce à un levier, alors que l'arrondissement est automatique, à l'aide d'une commande à main. Les machines SPA (automatiques) ont le pressage et la coupe à servocommande par piston hydraulique et l'arrondissement automatique en cycle unique. Toutes les machines sont montées sur roues avec pieds antivibrations.



В делителях для булочек моделей SA и SPM (полуавтоматических) используют систему округления, которая идеально и мягко имитирует движения рук.

Общие характеристики следующие:

- Голова стального литья;
- Ножи из нержавеющей стали;
- Электросварные стальные листы;
- Поддоны из поликарбоната;
- Регулировка в соответствии с размером;
- Голову и кольцо деления можно легко разобрать для чистки.

В машинах модели SPM (полуавтоматических) опускание головы, прессование и деление осуществляются с помощью рукоятки, в то время как округление производится автоматически с ручным контролем. В моделях SPA (автоматических) прессование и деление осуществляются с помощью гидравлического оперативного запоминающего устройства, а автоматическое округление за один цикл. Все машины установлены на колеса с антивibrационными опорами.





## Panificazione Bakery



### “Spezzatrici Esagonali ” Hexagonal Dividers



Modello Model	Descrizione Description	KW	Peso Weight (Kg)	Alimentazione Voltage	N. divisioni Pieces nr.	Pezzi Pieces (gr. Min/Max)	Dimensioni Dimension (mm)
<b>SPEZZATRICI ESAGONALI/HEXAGONAL DIVIDERS</b>							
SME 37	Spezzatrice esagonale manuale Manual hexagonal divider	-	175	-	37	30-130	615x685x1100
SE 37	Spezzatrice esagonale automatica Automatic hexagonal divider	0,75	230	400/3/50	37	30-130	615x685x1100

#### CARATTERISTICHE TECNICHE GENERALI GENERAL TECHNICAL CHARACTERISTICS

- Struttura in acciaio elettrosaldato, zincato e verniciata
- Coperchio in fusione di alluminio
- Coltelli e vasca acciaio inox
- Pressini in polietilene alimentare
- Normative CE
- Certificazioni ETL, CSA
- Painted galvanized and electro-welded steel structure
- Aluminium cast cover
- Stainless steel knives and basin
- Food-safe polyethylene presses
- CE rules
- ETL, CSA certified

#### OPTIONALS

- Tensioni Speciali
- Special tensions



Le spezzatrici presentate sono concepite per dividere pastoni di pasta da pane in 37 pezzi di forma esagonale. La dimensione dell'esagono può essere 57 oppure 62 nella versione maggiorata. I pezzi di pasta possono essere utilizzati per pane soffiato oppure successivamente arrotondati o arrotolati per tutte le forme desiderate.

Le caratteristiche generali sono:

- Struttura in lamiera elettrosaldata verniciata a forno
- Vasca, coltelli e piatto coperchio in acciaio inox
- Pressori in resina acetica alimentare

Per le versioni manuali i movimenti sono mediante leverismi mentre per le versioni automatiche i servomeccanismi sono a comando oleodinamico. Il tempo di pressatura è regolabile mediante PLC mentre il ciclo di lavoro, pressatura, taglio e apertura coperchio sono completamente automatici. Il pannello di comando è provvisto di un pulsante per la pulizia dei coltelli.



Diese Maschinen haben das Ziel Brotteigrollen in 37 sechseckigegeformte Brotteile zu schneiden. Die Größe des Sechsecks geht von einem Durchmesser von 57, bis zur Maximalgröße von 62. Die Brotstücke können danach für innen hohle Brötchen oder für andersförmig gewünschte Brötchen verarbeitet werden.

Die Beschaffenheit der Maschine:

- Elektrogeschweißtes Blech mit im
- Offen gebrannte Lackierung
- Schüssel, Messer, Teller und Deckel aus Inox-Stahl

Druckpressen aus Harzacetat (Resina) für Speisen Manuellbetriebene Maschinen werden mit Hebeleinrichtungen bedient. Automatisierte Maschinen haben öldynamische Servoeinrichtungen. Die Presszeit ist durch PLC regulierbar, der Arbeitsablauf, Pressen, Zerkleinern und Deckelöffnung ist vollkommen automatisch geregelt Für die Reinigung der Messer, ist ein Knopf am Bedienungsfeld zu drücken.



The presented dividers are planned to divide batches of dough for bread in 37 pieces of hexagonal shape. The dimension of the hexagon can be of 57 or 62 in the increased version. The pieces of dough can be used for puffed bread or they can be rounded or rolled afterwards to obtain any desired shape.

The general features are:

- Structure of stove enamelled electrowelded sheet
- Bowl, knives and lid plate in stainless steel
- Pressure rollers in acetatic resin suitable for food

For manual versions the movements are produced by leverisms and for the automatic versions the servomechanisms have oil-pressure controls. Pressing time can be regulated by PLC while working cycle, pressing, cutting and lid opening are completely automatic. The control panel is provided with a button for the knives cleaning.



Las partidoras de pan que se presentan se crearon para dividir amasijos de pasta de pan en 37 piezas de forma hexagonal. La medida del hexágono puede ser 57 o 62 en la versión aumentada. Las piezas de pasta se pueden utilizar para pan hueco o, a continuación, redondeado o arrollado para todas las formas deseadas.

Las características generales son las siguientes:

- Estructura de chapa electrosoldada pintada en horno
- Cuba, cuchillas y plato de tapa de acero inoxidable
- Compresores de resina acetálica alimentaria

Para las versiones manuales, los movimientos se realizan con palancas; mientras que para las versiones automáticas, los servomecanismos se realizan con mando oleodinámico. El tiempo de prensado se regula con el PLC mientras el ciclo de trabajo, el de prensado, el de corte y el de apertura de la tapa son completamente automáticos. El panel de mando presenta un botón para la limpieza de las cuchillas.



Les machines à couper la pâte à pain en hexagone présentées sont conçues pour diviser les pâtons de pâte à pain en 37 morceaux de forme hexagonale. La dimension de l'hexagone peut être de 57 ou de 62 dans la version plus grande. Les morceaux de pâte peuvent être utilisés pour le pain soufflé ou ils peuvent être successivement arrondis ou enroulés pour obtenir toutes les formes souhaitées.

Les caractéristiques sont généralement:

- Structure en tôle électro-soudée vernie au four
- Bac, couteaux et plateaux couvercle en acier inox
- Presseurs en résine d'acétal alimentaire

Pour les versions manuelles, les mouvements sont commandés par des leviers alors que pour les versions automatiques les servomécanismes sont à commande oléo-dynamique. Le temps de pressage est réglable grâce à PLC alors que le cycle de travail, pressage, coupe et ouverture du couvercle sont complètement automatiques. Le panneau de commandes est pourvu d'un bouton pour le nettoyage des couteaux.



Представляемые делители предназначены для деления кусков теста на 37 частей шестиугольной формы. Количество кусков может быть 57 или 62 в увеличенной версии. Можно также делить слоеное тесто, а куски потом округлить или закатать для получения желаемой формы. Общие характеристики следующие:

- Эмалированные сварные листы для печей
- Дежа, ножи и крышка из нержавеющей стали
- Прижимные валики из пищевой резины

На механических моделях движение производится с помощью рукоятки. На автоматических моделях управление производится с помощью масляного манометра. Время деления можно регулировать во время рабочего цикла через ПЛУ. Прессование, деление и открывание крышки осуществляются полностью автоматически. Панель управления оснащена кнопкой для чистки ножей.



## Panificazione Bakery



### “Spezzatrici Quadre” Square Dividers



Modello Model	Descrizione Description	KW	Peso Weight (Kg)	Alimentazione Voltage	N. divisioni Pieces nr.	Pezzi Pieces (gr. Min/Max)	Dimensioni Dimension (mm)
<b>SPEZZATRICI QUADRE/SQUARE DIVIDERS</b>							
<b>SQM 20</b>	Spezzatrice quadra manuale Manual square divider	0,75	240	-	20	80-350	615X685X1100
<b>SQ 20</b>		0,75	250	400/3/50	20	150-800	615X685X1100
<b>SQ 24</b>	Spezzatrice quadra automatica Automatic square divider	0,75	250	400/3/50	24	120-650	615X685X1100
<b>SQ 30</b>		0,75	250	400/3/50	30	90-530	615X685X1100
<b>SQ 20 SA</b>		0,75	240	400/3/50	20	150-800	615X685X1100
<b>SQ 24 SA</b>	Spezz. quadra semiautomatica Semi automatic square divider	0,75	240	400/3/50	24	120-650	615X685X1100
<b>SQ 30 SA</b>		0,75	240	400/3/50	30	90-530	615X685X1100
<b>SQ 20 SA M</b>	Spezz. quadra semiautomatica maggiorata Semi automatic square divider high volume	0,75	240	400/3/50	20	150-1000	615X685X1100
<b>SQGSA*</b>	Spezz. quadra semiautomatica con griglie Semi automatic square divider with cutting grid	0,75	240	400/3/50	20	150-1000	615X685X1100
<b>PBA</b>	Pressa burro/Butter and dough press	0,75	240	400/3/50	1	0/20000	615X685X1100

#### CARATTERISTICHE TECNICHE GENERALI GENERAL TECHNICAL CHARACTERISTICS

- Struttura in acciaio elettrosaldato, zincato e verniciata
- Coperchio in fusione di alluminio
- Coltelli e vasca acciaio inox
- Pressini in polietilene alimentare
- Normative CE
- Certificazioni ETL, CSA
- Painted galvanized and electro-welded steel structure
- Aluminium cast cover
- Stainless steel knives and basin
- Food-safe polyethylene presses
- CE rules
- ETL, CSA certified

#### OPTIONALS

- Tensioni Speciali
- Griglie taglio con diversi formati per SQGSA\*
- Special tensions
- Different cutting grid shapes for SQGSA\*



SQM 20



SQ 20-24-30



SQ-SA 20-24-30  
e PBA



SQGSA



# Panificazione Bakery



## “Griglie”

Griglie di taglio per spezzatrici quadre  
Cutting grid for semi automatic square dividers

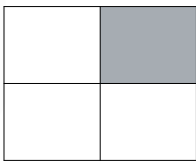

Griglia / Grid  
4 Divisioni / Div.  
Pz. singolo / Single pcs.  
254x202 mm

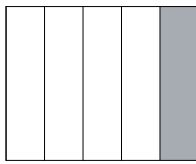

Griglia / Grid  
5 Divisioni / Div.  
Pz. singolo / Single pcs.  
100x400 mm

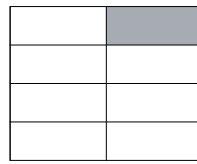

Griglia / Grid  
8 Divisioni / Div.  
Pz. singolo / Single pcs.  
250x100 mm

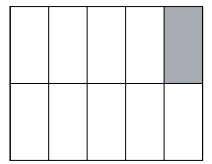

Griglia / Grid  
10 Divisioni / Div.  
Pz. singolo / Single pcs.  
100x200 mm

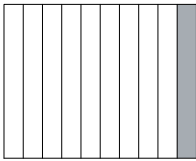

Griglia / Grid  
10 Divisioni / Div.  
Pz. singolo / Single pcs.  
50x400 mm

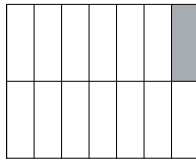

Griglia / Grid  
14 Divisioni / Div.  
Pz. singolo / Single pcs.  
70x200 mm

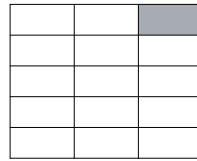

Griglia / Grid  
15 Divisioni / Div.  
Pz. singolo / Single pcs.  
170x80 mm

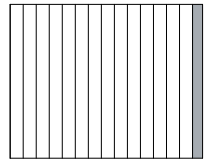

Griglia / Grid  
15 Divisioni / Div.  
Pz. singolo / Single pcs.  
31x400 mm

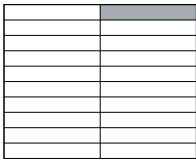

Griglia / Grid  
16 Divisioni / Div.  
Pz. singolo / Single pcs.  
250x50 mm

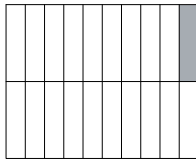

Griglia / Grid  
20 Divisioni / Div.  
Pz. singolo / Single pcs.  
50x200 mm

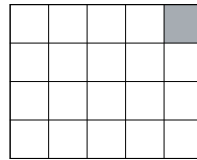

Griglia / Grid  
20 Divisioni / Div.  
Pz. singolo / Single pcs.  
100x100 mm

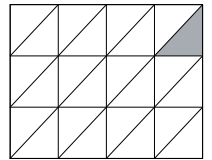

Griglia / Grid  
24 Divisioni / Div.  
Pz. singolo / Single pcs.  
134x126x184 mm

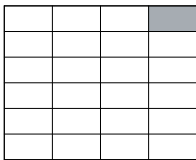

Griglia / Grid  
24 Divisioni / Div.  
Pz. singolo / Single pcs.  
66x125 mm

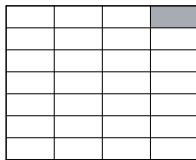

Griglia / Grid  
28 Divisioni / Div.  
Pz. singolo / Single pcs.  
57x126 mm

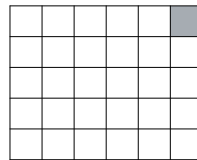

Griglia / Grid  
30 Divisioni / Div.  
Pz. singolo / Single pcs.  
80x80 mm

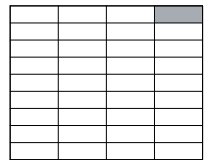

Griglia / Grid  
36 Divisioni / Div.  
Pz. singolo / Single pcs.  
44x162,5 mm

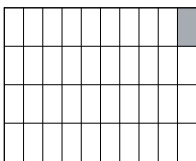

Griglia / Grid  
40 Divisioni / Div.  
Pz. singolo / Single pcs.  
50x100 mm

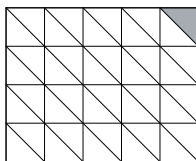

Griglia / Grid  
40 Divisioni / Div.  
Pz. singolo / Single pcs.  
100x100x140 mm

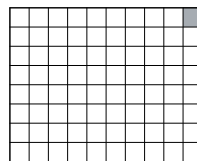

Griglia / Grid  
80 Divisioni / Div.  
Pz. singolo / Single pcs.  
50x50 mm



Macchina particolarmente adatta alla spezzatura di paste tenere per baguette, filoni, ecc. Vengono prodotti pezzi quadrati in varie divisioni e pezzature che successivamente possono essere formati o filonati.

Le caratteristiche sono:

- Struttura in lamiera d'acciaio elettrosaldata
- Le parti a contatto con l'impasto sono in acciaio inox oppure in polietilene alimentare
- Servomeccanismi azionati da centralina idraulica
- Tempo di pressatura regolabile da PLC
- Ciclo di pressatura, taglio e apertura coperchio completamente automatico
- Pulsante per pulizia coltelli

Alcuni modelli consentono di selezionare due tipi di pezzatura (10 o 20 oppure 15 o 30). I modelli semiautomatici denominati SA consentono di avere un ciclo di lavoro, pressatura e taglio azionato manualmente tramite selettore con apertura coperchio manuale.



Diese Maschine ist besonders für die Zubereitung von Baguette und Stangenbrot aus weichem Teig geeignet. Es können verschiedengroße viereckige Brotteile hergestellt werden, die anschließend beliebig weiterverarbeitet werden können.

Beschaffenheit der Maschine:

- Elektrogeschweißte Stahlstruktur
- Teile, die mit dem Teig in Berührung geraten sind aus Inox- Stahl oder Polyäthylen für Speisen
- Hydraulische Bedienung der Servoeinrichtungen
- Regulierbare Presszeit durch PLC
- Vollkommen automatisierter Arbeitsablauf für die Pressung, Zerstückelung und Deckelöffnung
- Knopf für die Messerreinigung

Bei einigen Modellen kann die Stückzahl (10,20 oder 15,30) eingestellt werden. Bei halbautomatisierten Maschinen mit der Aufschrift SA kann der Arbeitsgang bei geöffnetem Deckel, Pressen und Zerstückelung, nach Einstellung, durchgeführt werden.



This machine is especially suitable to divide soft doughs for baguette, long loafs, etc. It produces squared pieces in various divisions and sizes and afterwards they can be shaped or extended.

The characteristics are:

- Structure of electrowelded steel sheet
- Parts in contact with the dough are in stainless steel or in polyethylene suitable for food
- Servomechanisms moved by an hydraulic station
- Pressing time can be regulated by PLC
- Working cycle, pressing, cutting and lid opening are completely automatic
- Button for knives cleaning

Some models allow to select two kinds of size (10 or 20 otherwise 15 or 30). Semiautomatic models, named SA, allow to set manually a working cycle, pressing and cutting through a selector with manual lid opening.



Máquina especialmente apta para cortar las pastas como baguette, flauta, etc. Se producen piezas cuadradas en varias divisiones y pesos que, a continuación, se pueden formar o afilar.

Las características son las siguientes:

- Estructura de chapa de acero electrosoldada
- Las partes en contacto con el amasijo son de acero inoxidable o de polietileno alimentario
- Servomecanismos accionados desde una centralita hidráulica
- Tiempo de prensado regulable desde el PLC
- Ciclo de prensado, corte y apertura de la tapa completamente automático
- Botón para limpieza de las cuchillas

Algunos modelos permiten seleccionar dos tipos de tamaño (10 o 20 o 15 o 30). Los modelos semiautomáticos denominados SA permiten un ciclo de trabajo, prensado y corte accionado de manera manual con el selector con apertura manual de la tapa.



La machine est particulièrement adaptée pour couper la pâte molle pour les baguettes, ficelle, etc. Des morceaux carrés de divisions et pressages différents sont produits et peuvent successivement être formés et allongés.

Les caractéristiques sont:

- Structure en tôle d'acier électro-soudée
- Les parties en contact avec le pétrissage sont en acier inox ou en polyéthylène alimentaire
- Servomécanismes actionnés par la centrale hydraulique
- Temps de pressage réglable par PLC
- Cycle de pressage, coupe et ouverture du couvercle complètement automatique
- Bouton pour le nettoyage des couteaux

Certains modèles permettent de sélectionner deux types de pressages (10 ou 20 ou bien 15 ou 30). Les modèles semi-automatiques appelés SA permettent d'avoir un cycle de travail, pressage et coupe actionné manuellement grâce au sélecteur avec ouverture du couvercle manuelle.



Эта машина особенно пригодна для деления мягко- го теста для багета, длинных батончиков и др. Она делит тесто на кусочки разного веса и размера, а после им можно придать форму или увеличить.

Характеристики следующие:

- Сварные стальные листы
- Части, контактирующие с тестом, из нержавеющей стали или пищевого полиэтилена
- Механизм приводится в движение гидравлической системой
- Время деления можно регулировать через ПЛУ
- Рабочий цикл, прессование, деление и открытие крышки полностью автоматические
- Кнопка для чистки ножей

На некоторых моделях можно выбрать два размера (10 – 20 или 15 – 30). На полуавтоматических моделях, названных SA, можно вручную установить рабочий цикл, прессование и деление с помощью регулятора с ручным открытием крышки.





## Panificazione Bakery



### “Formatrici a 3 cilindri”

Formatrici per Baguette a 3 cilindri  
3 cylinders Baguette moulders



Modello Model	KW	Peso Weight (Kg)	Alimentazione Voltage	Dimensioni Dimension (mm)
FB700	0,55	240	400/3/50	1020X1050X1520

#### CARATTERISTICHE TECNICHE GENERALI GENERAL TECHNICAL CHARACTERISTICS

- Produzione da 120 a 1.200 gr
- Barra di sicurezza
- Cilindri laminatori in polietilene
- Regolazione separata cilindri e tappeti
- Montata su basamento con ruote
- Normative CE
- Certificazione GOST
- Production from 120 to 1.200 gr
- Safety bar
- Polythene sheeting cylinders
- Cylinders and clothes differently regulated
- Mounted on basement with wheels
- CE rules
- GOST certification

#### OPTIONALS

- Tesioni speciali
- Special tensions



La macchina è concepita secondo le più tradizionali regole per produrre ottime baguette e tutte le forme lunghe di pane. La pasta viene prima laminata e successivamente avvolta, arrotolata e allungata mediante due tappeti con senso di rotazione contrario. I cilindri di laminazione sono in materiale atossico e consentono una perfetta regolazione a seconda del peso della porzione di pasta. I tappeti di allungamento anche essi in materiale idoneo sono regolabili separatamente per ottenere l'allungamento desiderato a seconda del peso della porzione di pasta. È possibile produrre pezzi allungati del peso da 100 a 1200 grammi circa.



Diese Maschine ist nach traditionellen Kriterien entworfen und für die Herstellung ausgezeichneter Baguettes, sowie sämtlichen länglichen Brotformen hergestellt worden. Der Brotteig wird zuerst gewälzt, danach aufgerollt und anschließend, um sich drehende Fließbänder auf die gewünschte Länge ausgezogen. Die Zylinder der Walze sind aus ungiftigem Material und können auf das gewünschte Brotteiggewicht eingestellt werden. Auch die aus geeignetem Material gemachten Bänder, die das Brot in die gewünschte Form und Länge bringen, sind regulierbar. Es können von 100gr.- 1200gr. länglich geformte Brotteile hergestellt werden.



The machine is planned under the traditional rules to produce great baguettes and any loaves. The dough is laminated first and then wrapped, rolled and extended through two belts with opposite sense of rotation. The rolling cylinders are made of non-toxic material and they allow a perfect regulation according to the weight of the dough portion. The extension belts are also made of suitable material and they can be regulated separately to obtain the required extension according to the weight of the dough portion. It is possible to obtain long pieces from the weight of 100 grams to the weight of about 1200 grams.



La máquina está creada dentro de las reglas más tradicionales para producir óptimas baguette y todas las formas largas de pan. La pasta se lamina y, a continuación, se envuelve, se enrolla y se alarga con dos tapices con sentido de rotación opuesto. Los cilindros de laminación son de material atóxico y permiten una perfecta regulación del peso de la porción de pasta. Los tapices de alargue, también de material idóneo, se regulan por separado para lograr el alargue deseado según el peso de la porción de pasta. Es posible producir piezas alargadas de 100 a 1200 gramos de peso aproximadamente.



La machine est conçue selon les règles les plus traditionnelles pour produire les meilleures baguettes et tous les pains de forme allongée. La pâte est d'abord laminée et ensuite enroulée et allongée grâce à deux tapis ayant un sens de rotation contraire. Les cylindres de laminage sont en matériel atoxique et permettent un réglage parfait selon le poids de la portion de pâte. Les tapis d'allongement, également en matériel approprié, sont réglables séparément pour obtenir l'allongement désiré selon le poids de la portion de pâte. Il est possible de produire des morceaux allongés de poids de 100 à 1200 grammes environ.



Эта машина создана на основе традиционных правил производства больших багетов и всех хлебобулочных изделий длинной формы. Сначала раскатывают тесто, а затем сворачивают, закручивают и растягивают между двумя лентами с противоположным вращением. Вращающиеся цилиндры изготовлены из нетоксичных материалов и позволяют отлично отрегулировать процесс в соответствии с весом куска теста. Растягивающие ленты также изготовлены из соответствующих материалов. Их можно регулировать отдельно для достижения требуемого растяжения в соответствии с весом куска теста. Можно сформовать небольшие куски весом от 100 г и до 1200 грамм.



## Panificazione Bakery



FORMATRICI  
MOULDERS

### “Formatrici a 2 cilindri”

Formatrici per pane avvolto  
Long loaf moulders



Modello Model	KW	Peso Weight (Kg)	Alimentazione Voltage	Dimensioni Dimension (mm)
F600	0,75	130	400/3/50	825X1085X1205
TF600	0,75	180	400/3/50	825X2005X1205

#### CARATTERISTICHE TECNICHE GENERALI GENERAL TECHNICAL CHARACTERISTICS

- 2 cilindri da mm 600
- Pezzatura da 20 a 1500 gr
- Scivolo di ritorno
- Normative CE
- Montata su ruote
- Two cylinders mm 600
- Pieces weight from 20 to 1500 gr
- Return chute
- CE rules
- Mounted on wheels

#### OPTIONALS

- Tesioni speciali
- Special tensions



La macchina proposta rispecchia le funzioni tipiche che l'hanno resa indispensabile per ottenere in ogni panificio "banane", "filoni" e ogni altra forma "avvolta".

Sono stati ampliati i limiti di uso della macchina fino a consentire la produzione di pezzi da un minimo di 25 gr ad un massimo di 1000 gr di peso. Nuovi comandi, che si sviluppano sui 360°, consentono la migliore regolazione possibile dello spessore di laminazione e del numero di avvolgimenti voluti.

La trasmissione al tappeto superiore può essere disinserita, lasciandolo fermo, mentre il resto della macchina funziona: ciò consente di usarla come piccolo cilindro. La formatrice non necessita di alcuna manutenzione particolare: i tre tappeti sono smontabili per l'eventuale ricambio.

Il moderno aspetto rispecchia le nuove concezioni igieniche per una facile pulizia ed un'altrettanto facile ispezionabilità della macchina, rispettando inoltre le nuove regole europee riguardanti le norme antinfortunistiche.

Il filonatore motorizzato consente, accostandolo alla formatrice, di ottenere una efficace formatrice-filonatrice per tutte le forme di pane allungato come baguette, filoni, grissini filonati ecc.



Die angebotene Maschine enthält alle typische Funktionen, die sie unentbehrlich gemacht haben, um in jeder Bäckerei perfekte lange Brötchen, Baguettes und jede andere "aufgerollte" Form zu produzieren.

Die neueste Konstruktion mit dem Computer hat die Entwicklung einer modernen, hochqualitativen Maschine mit hoher Technologie erlaubt. Die Anwendungsgrenzen der Maschine sind so erweitert worden, dass nun eine Produktion von Brotteigstücken von 25 gr bis 1000 gr Gewicht möglich ist. Neue Steuerungen, die sich auf 360° erstrecken, erlauben die bestmögliche Einstellung der Walzstärke und der Anzahl der gewünschten Wicklungen. Durch die weite Rücklaufrolle kann die Maschine auch von einem einzigen Bediener bedient werden. Die Übertragung zum oberen Teppich kann ausgeschaltet werden: der Teppich bleibt stehen, während die restlichen Teile der Maschine laufen weiter und die Einheit kann als kleiner Zylinder verwendet werden. Die Formmaschine braucht keine besondere Wartung: die drei Teppiche können für die Auswechslung leicht abmontiert werden. Diese moderne Ausführung entspricht den neuen Hygienevorschriften und erlaubt eine einfache Reinigung und eine bequeme Inspektion der Maschine und dies unter Beachtung der neuen EG-Sicherheitsvorschriften. Durch die Montage einer zusätzlichen motorisierten Ziehvorrichtung erhält man eine Zieh- und Formmaschine, die die Produktion von allen länglichen Brotformen, wie Baguette oder Grissini, erlaubt.



The machine proposed here performs the typical functions which have made it indispensable for any bakery to obtain "banana" shaped bread, loaves and any other kind of "folded" shapes. Updated computer-aided design has made it possible to create a modern machine, featuring improved quality and top-level technology.

The machine operating limits have been extended to cover a production range of pieces from a minimum of 25 g. to a maximum of 1000 g. New controls developed over 360° allow the best possible adjustments for any laminating thickness and folding required.

Thanks to the wide return slide, the machine can be operated by just one person. Transmission to the upper belt can be disconnected to leave it stopped; meanwhile the rest of the machine can continue to operate and be used as a small cylinder.

The machine requires no special maintenance, the three belts can be removed for replacement. Its modern appearance reflects the new hygienic concepts for easy cleaning and easy inspection; moreover the machine respects the new European rules concerning accident-prevention standards. The motor-driven loaf moulder, when fitted alongside the moulder, makes it possible to obtain an efficient combination for producing all longer bread shapes, such as French baguette, loaves, long grissini etc.



La máquina propuesta refleja las funciones típicas que la hacen indispensable para obtener en cada panificacón "bananas", "flautas" y cualquier otra forma "envuelta". Se ampliaron los límites de uso de la máquina hasta permitir la producción de piezas de un mínimo de 25 g a un máximo de 1000 g de peso. Nuevos mandos, que se desarrollan a 360°, permiten la mejor regulación del espesor de laminación y del número de envolvimientos deseados. La transmisión al tapiz superior se puede quitar y dejar quieto, mientras que el resto de la máquina funciona: esto permite usarla como un cilindro pequeño. La modeladora no requiere mantenimiento especial: los tres tapices se desmontan para un posible recambio. El aspecto moderno respeta las nuevas concepciones higiénicas para una fácil limpieza y inspección de la máquina, dentro del respeto de las nuevas reglas europeas sobre normas contra accidentes.

El molde motorizado permite, al acercarlo a la moldeadora, lograr una eficaz moldeadora para las formas de pan largo como baguette, flauta, colines alargados, etc.



La machine proposée reflète les fonctions typiques qui l'ont rendue indispensable pour obtenir dans chaque boulangerie des "bananes", des "baguettes" et toutes les autres formes "enroulées".

Les limitations d'emploi ont été élargies jusqu'à permettre la production de morceaux de pâte à pain d'un minimum de 25 g. à un maximum de 1000 g. de poids.

De nouvelles commandes, qui se développent sur 360°, permettent le meilleur réglage possible de l'épaisseur du feuilletage et du nombre d'enroulement désirés.

La transmission au tapis supérieur peut être déconnectée, en le laissant arrêté, tandis que le reste de la machine est en marche, ceci permet de l'utiliser en tant que petit cylindre.

La façonneuse n'a besoin d'aucun entretien spécial: les trois tapis sont démontables pour éventuellement pouvoir les changer.

Son aspect moderne reflète les nouvelles conceptions hygiéniques pour un nettoyage facile et une inspection tout autant aisée de la machine, en respectant en outre les nouvelles règles européennes en matière de mesures pour la prévention des accidents.

Le dispositif motorisé pour former les baguettes permet, avec la façonneuse d'obtenir une machine pour baguettes très efficace pour toutes les formes de pain allongé telles que les baguettes, les grissins ect...



Представленная здесь машина выполняет типичные функции, которые делают ее незаменимой в любой пекарне для формования хлеба в форме банана, длинных батонов и любых других видов закрученного хлеба. Современный компьютерный дизайн дал возможность создать современную машину с улучшенным качеством и высокими технологиями. Были расширены ограничения возможности машины, чтобы иметь возможность работать с продуктами с минимальным весом от 25 г до максимального веса в 1000 г. Новые контрольные механизмы, работающие с размахом на 360 градусов, позволяют проводить настройки для раскатки теста любой толщины и количества слоев. Благодаря широкому возвратному ползунку, машиной может управлять один человек. Передачу на верхний ремень можно отсоединить и прекратить, в то время как сама машина продолжает работу и будет использоваться для маленького цилиндра. Эта машина не требует специального технического обслуживания. Три ремня можно снять для замены. Ее современный внешний вид отвечает новой концепции по гигиене для упрощения чистки машины и контроля за ее работой. Более того, эта машина отвечает новым европейским стандартам по предупреждению травматизма. Приводная формовочная машина для длинных батонов, когда полностью укомплектована, дает возможность эффективно производить хлеб длинной формы, такой как французский багет, длинные батоны, хлебные палочки и др.



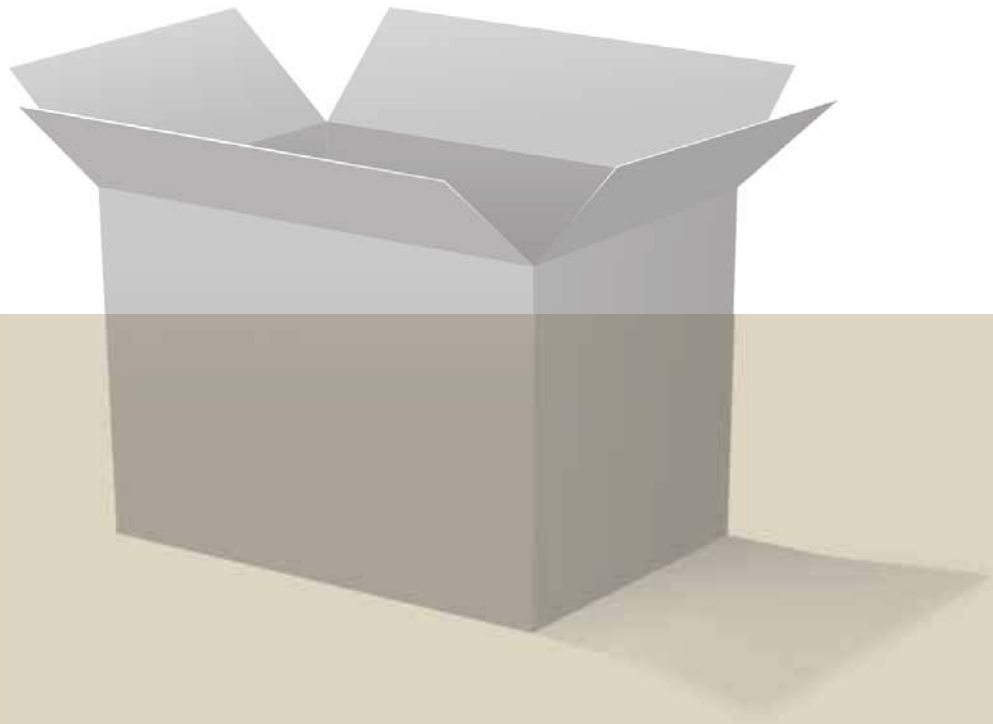

# Imballi Packaging



## Imballi Packaging



	Modello Model	Scatole su pallet Box on to pallet			Gabbia/ cassa Cage / Crate			
		lengt mm	width mm	height mm	length mm	width mm	height mm	
PLANETARIE MIXERS	CHEF 7,5	630	410	770	700	530	780	
	CHEF 10	750	700	1.100	980	830	1.160	
	CHEF 20	750	700	1.100	980	830	1.160	
	CHEF 20 H	750	700	1.500	870	780	1.500	
	CHEF 30	750	700	1.500	870	780	1.500	
	CHEF 40	940	650	1.600	1.060	900	1.550	
	CHEF 60	1.100	870	1.770	1.130	980	1.830	
	BM 10	750	700	1.100	980	830	1.160	
	BM 20	750	700	1.100	980	830	1.160	
	BM 20 H	750	700	1.500	870	780	1.500	
	BM 30	750	700	1.500	870	780	1.500	
	BM 40	940	650	1.600	1.060	900	1.550	
	BM 60	1.100	870	1.770	1.130	980	1.830	
	BM 80	1.100	870	1.770	1.130	980	1.830	
GRINDERS	RF 300	940	650	1.600	1.060	900	1.550	
CUOCTORI COOKERS	CC 30	740	940	1.610	1.060	900	1.550	
	CC 50	740	940	1.610	1.060	900	1.550	
	EC 30	740	940	1.610	1.060	900	1.550	
	EC 60	740	940	1.610	1.060	900	1.550	
SFOGLIATRICI SHEETERS	SFG 500B	1.370	840	870	1.320	900	910	
	SFG500T	1.370	840	1.630	1.420	930	1.560	
	SFG500TM	1.370	840	1.630	1.420	930	1.560	
	SFG600TM	1.370	840	1.630	1.420	930	1.560	
	SFG 600 TMM	-	-	-	1.420	900	1.850	
	SFG 600 TL	-	-	-	1.420	900	1.850	
PIZZA	TAURO 12	630	400	760	700	530	780	
	TAURO 18	630	400	760	700	530	780	
	TAURO 22	830	570	960	890	650	1.040	
	TAURO 22 2 V.	830	570	960	890	650	1.040	
	TAURO 25	830	570	960	890	650	1.040	
	TAURO 25 V	830	570	960	890	650	1.040	
	TAURO 30	830	570	960	890	650	1.040	
	TAURO 30 2 V	830	570	960	890	650	1.040	
	TAURO 35	830	570	960	890	650	1.040	
	TAURO 35 2 V	830	570	960	890	650	1.040	
	TAURO 40	830	570	960	890	650	1.040	
	TAURO 40 2 V	830	570	960	890	650	1.040	
	TAURO 35 A	830	570	960	890	650	1.040	
	TAURO 40 A	830	570	960	890	650	1.040	
	TAURO TUBOLAR BASE	500	150	700	-	-	-	

## Imballi Packaging



	Scatole su pallet Box on to pallet			Gabbia/ cassa Cage / Crate			
	Modello Model	length mm	width mm	height mm	length mm	width mm	
PIZZA	DR 14	750	700	1.100	980	830	1.160
	DR 11	750	700	1.100	980	830	1.160
	TUBOLAR BASE DR - SPZ	1.130	910	310	-	-	-
	SFERA	830	570	960	890	650	1.040
	SPZ 40	750	900	1.100	980	830	1.160
	SPZ 50	750	900	1.100	980	830	1.160
	SPZ Automatic	750	900	1.100	980	830	1.160
	T 50	750	700	1.100	980	830	1.160
PLANETARIE MIXERS	AEROMIX 7,5	630	410	770	700	530	780
	AEROMIX 10	750	700	1.100	980	830	1.160
	AEROMIX 20	750	700	1.100	980	830	1.160
	AEROMIX 20 H	750	700	1.500	870	780	1.500
	AEROMIX 30	750	700	1.500	870	780	1.500
	AEROMIX 40	940	650	1.600	1.110	900	1.550
	AEROMIX 60	1.100	870	1.770	1.130	980	2.110
	AEROMIX 70	-	-	-	1.130	980	2.110
	AEROMIX 80	-	-	-	1.130	980	2.110
	AEROMIX 100	-	-	-	1.380	1.280	2.380
	AEROMIX 120	-	-	-	1.380	1.280	2.380
	AEROMIX 160	-	-	-	1.380	1.280	2.380
	AMX 120-160 BOWL	-	-	-	900	900	1.050
	PE 60 DT	-	-	-	1.130	980	1.992
	PE 70 DT	-	-	-	1.130	980	1.992
	PE 80 DT	-	-	-	1.130	980	1.992
	PE 100	-	-	-	1.380	1.280	2.380
	PE 120	-	-	-	1.380	1.280	2.380
PE 160	-	-	-	1.380	1.280	2.380	
PE 120-160 BOWL	-	-	-	900	900	1.050	
IMPASTATRICE A SPIRALE SPIRAL MIXERS	SL 50	940	650	1.600	1.060	900	1.550
	SL 60	940	650	1.600	1.060	900	1.550
	SL 60 PLUS	1.370	840	1.630	1.450	950	1.610
	SL 80	1.370	840	1.630	1.450	950	1.610
	SL 120	1.370	840	1.630	1.450	950	1.610
	SL 160	-	-	-	1.680	1.130	1.780
	SL 200	-	-	-	1.680	1.130	1.780
	SL 280	-	-	-	1.980	1.280	1.780
	GREENLINE 50	940	650	1.600	1.110	900	1.550
	GREENLINE 60	940	650	1.600	1.110	900	1.550
	GREENLINE 80	1.370	840	1.630	1.450	950	1.610
	GREENLINE 120	1.370	840	1.630	1.450	950	1.610

## Imballi Packaging



	Scatole su pallet Box on to pallet			Gabbia/ cassa Cage / Crate			
	Modello Model	length mm	width mm	height mm	length mm	width mm	
IMPASTATRICI A SPIRALE SPIRAL MIXERS	SAU-B 120	-	-	-	2.380	1.680	2.060
	SAU-T 120	-	-	-	2.380	1.680	2.520
	SAU-B 160	-	-	-	2.380	1.680	2.060
	SAU-T 160	-	-	-	2.380	1.680	2.520
	SAU-B 200	-	-	-	2.380	1.680	2.060
	SAU-T 200	-	-	-	2.380	1.680	2.520
	SAU-B 280	-	-	-	2.380	1.680	2.060
	SAU-T 280	-	-	-	2.380	1.680	2.520
IMPASTATRICI INDUSTRIALI INDUSTRIAL MIXERS	VE 80	-	-	-	1.270	1.780	1.660
	VE 120	-	-	-	1.270	1.780	1.660
	VE 160	-	-	-	1.680	2.230	1.720
	VE 200	-	-	-	1.680	2.230	1.720
	VE 250	-	-	-	1.750	2.350	1.800
	VE 300	-	-	-	1.750	2.350	1.800
	CVE 80-120	-	-	-	1.140	920	1.100
	CVE 160-200	-	-	-	1.180	1.380	1.100
	CVE 250-300	-	-	-	1.560	1.300	1.180
	VE 160 SP	-	-	-	1.680	2.230	1.720
	VE 200 SP	-	-	-	1.680	2.230	1.720
	VE 250 SP	-	-	-	1.750	2.350	1.800
	VE 300 SP	-	-	-	1.750	2.350	1.800
	CVE SP 160-200	-	-	-	1.180	1.380	1.100
	CVE SP 250-300	-	-	-	1.560	1.300	1.180
	GL 160 SF	-	-	-	1.680	2.230	2.100
	GL 200 SF	-	-	-	1.680	2.230	2.100
	GL 250 SF	-	-	-	1.750	2.350	2.100
GL 300 SF	-	-	-	1.750	2.350	2.100	
IMPASTATRICI A SPIRALE SPIRAL MIXERS	IBT 40	870	890	1.700	-	-	-
	IBT 50	950	1.080	1.750	-	-	-
	IBT 60	950	1.080	1.750	-	-	-
	IBT 80	950	1.150	1.800	-	-	-
	IBT120	1.070	1.280	2.000	-	-	-
	IBT160	1.070	1.280	2.000	-	-	-
	FM125	-	-	-	1.280	980	1.200
	FM200	-	-	-	1.580	1.220	1.550
FM300	-	-	-	1.580	1.220	1.550	
TRAMOGGE FEEDING HOPPERS	TR 350	-	-	-	2.230	1.580	1.180
	TR 400	-	-	-	2.230	1.580	1.180
	TR 500	-	-	-	2.230	1.580	1.180

# Imballi Packaging



		Scatole su pallet Box on to pallet			Gabbia/ cassa Cage / Crate			
	Modello Model	length mm	width mm	height mm	length mm	width mm	height mm	
SOLLEVATORI LIFTERS	MACISTE 1300	-	-	-	1.780	1.280	1.840	
	MACISTE 1600	-	-	-	2.480	1.780	2.150	
	MACISTE 1900	-	-	-	2.480	1.780	2.150	
	MACISTE 2600	-	-	-	3.280	1.780	2.150	
	MACISTE MAX 1600	-	-	-	2.480	1.780	2.150	
	MACISTE MAX 1900	-	-	-	2.480	1.780	2.150	
	MACISTE MAX 2600	-	-	-	3.280	1.780	2.150	
	HERCULES	-	-	-	2.980	1.780	2.480	
	SVP M1	1.100	870	1.770	1.130	980	1.830	
	SVP 1	-	-	-	1.520	1.220	2.200	
	SVP 2	-	-	-	1.520	1.220	3.200	
	SINGLE TIPPER	-	-	-	1.900	3.150	1.250	
DOUBLE TIPPER	-	-	-	1.900	3.150	1.250		
SPEZZATRICI DIVIDERS	Spezzatrici volumetriche Volumetric dividers	-	-	-	2.100	1.000	1.500	
	CONICAL T1-T2	-	-	-	1.000	1.000	1.500	
	DOUBLE CONICAL T1-T2	-	-	-	1.400	1.100	1.900	
	SPM	750	740	1.670	830	830	1.510	
	SPA	750	740	1.670	830	830	1.510	
	SQ-SQM	750	740	1.670	830	830	1.510	
	SME-SE	750	740	1.670	830	830	1.510	
FORMATRICI MOULDERS	FB3-700	1.110	880	910	-	-	-	
	F600	740	940	1.610	-	-	-	
	Tavolo pressoio Table for long loaf device	1.200	800	1.000	-	-	-	



[www.sigmasrl.com](http://www.sigmasrl.com)

Numero Verde  
**800 948 484**



Sigma Srl  
via Artigianato, 85  
25030 Torbole Casaglia (BS) - Italy  
Tel. +39 030 2650488/479 - Fax +39 030 2650143  
[info@sigmasrl.com](mailto:info@sigmasrl.com)