

millennium



millennium

legendary display cabinet

IL MITO DELLA VETRINA PER IL GELATO ARTIGIANALE NEL MONDO

Un successo internazionale firmato ISA. Millennium è la vetrina gelato che migliaia di bar, catene di gelateria e gelatieri in tutto il mondo hanno già scelto per affidabilità e prestazioni. Millennium la riconosci per il carattere brillante, la dotazione tecnologica e le motorizzazioni potenziate. È stata progettata e testata in classe climatica 7, +35° di temperatura ambientale e con il 75% di umidità relativa per questo ti offre prestazioni eccellenti in tutte le condizioni ambientali di lavoro.

EN

THE LEGENDARY DISPLAY CABINET FOR HOMEMADE ICE CREAM WORLDWIDE

An international success by ISA.

Millennium is the ice cream display cabinet that thousands of bars, ice cream shops and vendors all over the world have already chosen for its reliability and performance. You instantly recognize Millennium for its brilliant character, its hi-tech construction and enhanced power system. It is designed and tested in climate class 7 with a room temperature of +35° and 75% relative humidity, which are a guarantee of its outstanding performance in all types of environmental conditions. ISA reliability, top-quality constructional materials and the digital temperature adjustment pre-set for -20 +2°C ensure the ideal efficiency-consumption ratio. Its structural technology and tilted display counter give the product on display the best possible food appeal.

DE

DIE FANTASTISCHSTE THEKE FÜR HAUSGEMACHTES EIS AUF DER WELT

Ein von ISA signierter internationaler Erfolg.

Millennium ist die Eistheke, für die sich bereits Tausende von Bars, Eisdielenketten und Eisverkäufer auf der ganzen Welt wegen seiner Verlässlichkeit und Leistungsfähigkeit entschieden haben. Millennium erkennen Sie an Ihrem brillianten Charakter, der technischen Ausrüstung und dem leistungsstarken Motorisierung. Sie wurde entworfen und getestet in der Klimaklasse 7 +35° für den Einsatz bei Raumtemperatur und 75% relativer Luftfeuchtigkeit, deswegen bietet sie Ihnen hervorragende Leistungen in jeder Arbeitsumgebung. Die Produktverlässlichkeit ISA, das hochwertige Baumaterial und die digitale Temparturregelung für -20° bis +2°c garantieren für ein ideales Leistung-Konsum-Verhältnis. Die technologische Architektur, der geneigte Ausstellungstresen geben dem ausgestellten Produkt das größtmögliche Food Appeal.

FR

LE MYTHE DE LA VITRINE POUR LES GLACES ARTISANALES DANS LE MONDE

Un succès international signé ISA. Millennium est la vitrine pour glaces que des milliers de bars, de chaînes de vente de glaces et de glaciers du monde entier ont déjà choisie pour sa fiabilité et ses performances. Tu reconnais Millennium pour son caractère brillant, sa technologie et ses motorisations améliorées. Elle a été conçue et testée en classe climatique 7 +35° à température ambiante et avec 75% d'humidité relative ; c'est pour cela qu'elle t'offre des performances excellentes dans toutes les conditions environnementales de travail. La fiabilité ISA, les matériaux de construction de haute qualité et le réglage numérique de la température configuré pour -20° +2°C garantissent un rapport idéal entre efficacité et consommation. La technologie structurelle, le plan d'exposition incliné donnent au produit exposé le meilleur food appeal possible.

ES

EL MITO DE LA VITRINA PARA EL HELADO ARTESANAL EN EL MUNDO

Un éxito internacional firmado ISA.

Millennium es la vitrina helado que miles de bares, cadenas de heladerías y heladeros de todo el mundo han elegido ya por su fiabilidad y prestaciones. Millennium se reconoce por su carácter brillante, su dotación tecnológica y la potenciación de sus motorizaciones. Ha sido proyectada y testada en clase climática 7 +35° de temperatura ambiente y con el 75% de humedad relativa, por eso te ofrece unas prestaciones excelentes en todas las condiciones ambientales de trabajo. La fiabilidad ISA, los materiales constructivos de elevada calidad y la regulación digital de la temperatura predispuesta para -20°+2°c garantizan una relación idean eficacia-consumo. La tecnología estructural y la superficie expositiva inclinada, brindan al producto el máximo food appeal posible.





L'UNICA VETRINA GELATO CON REFRIGERANTE NATURALE A CO₂ O IDROCARBURI. A VOI LA SCELTA.



Millennium è disponibile anche nella versione Aria che utilizza il refrigerante naturale a base di R744A (CO₂) o R290 (Idrocarburi) al posto dei tradizionali fluidi refrigeranti: una soluzione tecnologica all'avanguardia, resa possibile da anni di ricerca e sviluppo sull'impiego di nuovi fluidi refrigeranti eco-friendly e che apre nuovi orizzonti in tema di ecosostenibilità, contenimento delle emissioni nocive e rispetto per l'ambiente senza rinunciare alle prestazioni e all'efficienza refrigerante.

EN

THE ONLY ICE CREAM DISPLAY CABINET WITH NATURAL REFRIGERANT WITH CO₂ OR HYDROCARBONS. THE CHOICE IS YOURS.

Millennium is also available R744 (CO₂) or R290 (hydrocarbons) in the Air version that uses the natural CO₂ based refrigerant instead of traditional refrigerants: a cutting-edge technological solution, made possible by years of research and development on the use of new eco-friendly refrigerants and which opens up new horizons in terms of eco-sustainability, reduction of harmful emissions and environmental awareness without compromising on performance and cooling efficiency.

DE

DIE EINZIGE EISTHEKE MIT NATÜRLICHEM CO₂-KÄLTEMITTEL ODER KOHLENWASSERSTOFFEN SIE HABEN DIE WAHL.

Millennium ist auch mit R744 (CO₂) oder R290 (Kohlenwasserstoffe) in der Ausführung Aria erhältlich, die statt den herkömmlichen Kälteflüssigkeiten das natürliche CO₂-Kältemittel nutzt: diese fortschrittliche technologische Lösung ist dank Jahren der Forschung und Entwicklung von neuen, umweltfreundlichen Kälteflüssigkeiten möglich und eröffnet neue Horizonte zum Thema Nachhaltigkeit, Einschränkung der Schadstoffemissionen und Umweltschutz, ohne dass die Leistungen und die korrekte Kühlung beeinträchtigt werden.

FR

LA SEULE VITRINE GLACE AVEC DU RÉFRIGÉRANT NATUREL À CO₂ OU HYDROCARBURES. VOUS AVEZ LE CHOIX.

millennium est également disponible R744 (CO₂) ou R290 (hydrocarbures) dans la version Air qui utilise le réfrigérant naturel à base de CO₂ au lieu des fluides réfrigérants traditionnels: une solution technologique de pointe, rendue possible par des années de recherche et de développement sur l'utilisation de nouveaux réfrigérants « eco-friendly » et qui ouvre de nouveaux horizons en termes de durabilité, de réduction des émissions nocives et de respect de l'environnement sans renoncer aux performances et à l'efficacité réfrigérante.

ES

EL ÚNICO EXPOSITOR DE HELADOS CON REFRIGERANTE NATURAL DE CO₂ O HIDROCARBUROS. LA ELECCIÓN ES SUYA.

millennium está disponible también con R744(CO₂) o R290 (hidrocarburos) en la versión Aire, que utiliza el refrigerante natural a base de CO₂ en lugar de los tradicionales fluidos refrigerantes: una solución tecnológica a la vanguardia, fruto de años de investigación y desarrollo sobre el uso de nuevos fluidos refrigerantes eco-friendly y que abre nuevos horizontes en tema de sostenibilidad ecológica, contención de las emisiones nocivas y respeto del medio ambiente sin renunciar a las prestaciones y a la eficiencia refrigerante.

millennium



ENERGY SAVING
LED



INSTALLATION
Plug-in / Remote unit



TEMPERATURE
-20 / +2 °C



DEFROST
Reverse cycle



CLIMATIC CLASS
7

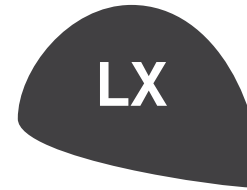

LA GAMMA

Oggi Millennium moltiplica il successo e aggiunge alla gamma altri due modelli per soddisfare i nuovi canoni, estetici di una clientela sempre più selettiva. Millennium è il palcoscenico che trasforma l'occasione di consumo del gelato in un evento spettacolare. Tutti i modelli rispettano le rigorose norme di certificazione CE per l'Europa e UL per il Nord America.

JXEN**THE RANGE**

Millennium now multiplies its success and adds two other models to its range that are designed to satisfy the new stylistic standards of increasingly selective customers. Millennium is the grand stage that transforms the act of enjoying a nice ice cream into a spectacular event. All models are compliant with the strict CE certification standards for Europe and UL for North America.

FR**LA GAMME**

Chaque Millennium multiplie le succès et ajoute à la gamme deux autres modèles pour satisfaire les nouveaux canons esthétiques d'une clientèle toujours plus sélective. Millennium est le décor qui transforme l'occasion de déguster une glace en un événement spectaculaire. Tous les modèles respectent rigoureusement les normes de certification CE pour l'Europe et UL pour l'Amérique du Nord.

STDE**DIE PRODUKTAUSWAHL**

Heute setzt Millennium seinem Erfolg noch einen auf und fügt seiner Auswahl an Produkten zwei weitere Modelle zu, um dem neuen ästhetischen Muss einer immer wählerischen Kundschaft nachzukommen. Millennium ist die Bühne, auf welcher der Eisgenuss zu einem grandiosen Ereignis wird. Alle Modelle entsprechen den strengen Richtlinien der CE-Kennzeichnung für Europa und der UL-Kennzeichnung für Nordamerika.

ES**LA GAMA**

En la actualidad Millennium multiplica el éxito y añade a la gama otros dos modelos para satisfacer los nuevos cánones estéticos de una clientela cada vez más selectiva. Millennium es el escenario que transforma la ocasión de consumo del helado en un acontecimiento espectacular. Todos los modelos respetan las rigurosas normas de certificación CE para Europa y UL para Norteamérica.

millennium

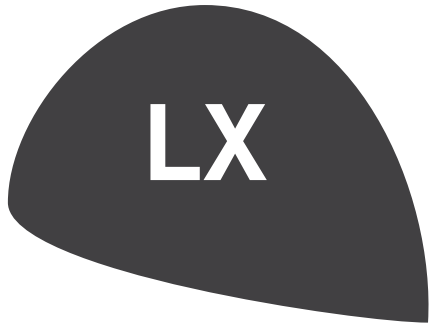

La versione con il vetro sferico è la Millennium che ha fatto la storia, un successo senza tempo. In tutte le versioni, la vasca espositiva interamente realizzata in acciaio inox e l'isolamento in poliuretano spessore 60mm con agente espandente CO₂ iniettato a densità 40kg/m³ massimizzano l'efficienza abbattendo i consumi energetici di esercizio. Millennium LX è una vetrina estremamente facile da allestire e funzionale alle diverse esigenze espositive.

EN

The version with sphere-shaped glass is the Millennium model that has made history, a timeless success. In all versions, the display cabinet is entirely made of stainless steel and includes insulating panels in polyurethane 60 mm thick, with CO₂ expanding agent injected at a density of 40 Kg/m³, maximizing efficiency by cutting down on operating energy costs. Millennium LX is a display cabinet that is extremely easy to install and that practically responds to individual requirements.

DE

Die Rundglasversion der Millennium-Theke schreibt eine zeitlose Erfolgsgeschichte. In allen Versionen maximieren die Ausstellungswanne aus Edelstahl und die 60mm dicke Polyurethan -Isolierung mit in einer Dichtigkeit von 40kg/m³ eingespritztem CO₂-Schaumstoff die Leistungsfähigkeit bei einem minimalen Energieverbrauch. Millennium LX ist eine besonders leicht einzurichtender und funktional auf die verschiedenen Ausstellungsanforderungen eingestellte Theke.

FR

Millennium est la version avec le verre sphérique qui a fait l'histoire, un succès infini. Dans toutes les versions, le bac d'exposition est entièrement fabriqué en acier inox et l'isolation en polyuréthane de 60mm d'épaisseur avec un agent d'expansion CO₂ injecté à une densité de 40kg/m³ qui permet d'optimiser l'efficacité en abattant la consommation énergétique d'exercice. Millennium LX est une vitrine extrêmement facile à aménager qui s'adapte à toutes les exigences d'exposition.

ES

La versión con el cristal esférico es la Millennium que ha hecho historia, un éxito intemporal. En todas las versiones, la pila expositiva totalmente fabricada en acero inoxidable y el aislamiento en poliuretano de espesor 60 mm con agente expansor CO₂ inyectado a densidad 40kg/m³, maximizan la eficacia reduciendo el consumo energético de ejercicio. Millennium LX es una vitrina extremadamente fácil de montar y que satisface las diferentes exigencias expositivas.





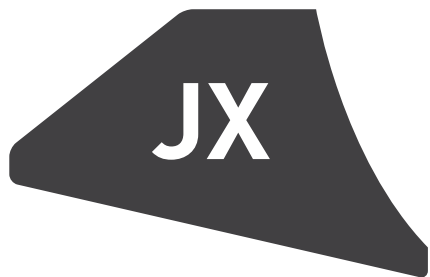

Il design inconfondibile di Millennium JX da un gusto più raffinato alla tua attività commerciale. Puoi anche personalizzare i rivestimenti anteriori con una vasta gamma di colori e visual. I modelli ST, JX, LX nella versione 12+12 sono Dual Temperature, grazie a due unità condensatrici indipendenti, permette la parzializzazione della refrigerazione e la possibilità di impostare contemporaneamente due diverse temperature all'interno della medesima vasca.

EN

The unmistakable design of Millennium Jx adds a refined touch to your business. You can even customize the front covering with a broad variety of colors and visual patterns. The ST, JX and LX models in the 12+12 version are dual temperature, thanks to two independent condensing units that allow you to differentiate cooling and simultaneously program two different temperatures inside the same ice cream tub.

DE

Das unverwechselbare Design des Millineum Jx schenkt ihrem Geschäft Esprit und Erlesenheit. Für die vordere Bekleidung gibt es eine breite Auswahl an Farben und Visuals für eine individuelle Gestaltung. Die Modelle ST, JX, LX in der Version 12+12 mit Dual-Temperatur erlauben dank zweier unabhängiger Kondensator Kühlung mit Teillast und die Möglichkeit gleichzeitig zwei verschiedene Temperaturen im Innern derselben Wanne einzustellen.

FR

Le design inimitable de millenium Jx donne une touche plus raffinée à ton activité commerciale. Tu peux aussi personnaliser les surfaces de devant avec une vaste gamme de couleurs et d'affichage. Les modèles ST, JX, LX dans la version 12+12 sont à température dual grâce à deux unités de condensation indépendantes, ce qui permet de rendre partielle la réfrigération et configurer en même temps deux températures différentes dans le même bac.

ES

El diseño inconfundible de Millennium Jx confiere un gusto más refinado a tu actividad comercial. Puedes personalizar también los revestimientos anteriores con una amplia gama de colores y visual. Los modelos ST, JX, LX en la versión 12+12 son de temperatura dual, gracias a dos unidades condensadoras independientes permiten la división de la refrigeración y la posibilidad de formular a la vez dos temperaturas distintas en el interior de la misma pila.







Il design deciso e sintetico di Millennium ST trova il suo habitat ideale negli ambienti in stile moderno e contemporaneo. Nuovo anche il sistema di illuminazione che si avvale della tecnologia a led presente in tutte le versioni.

EN

The strong and minimalist design of Millennium ST finds its ideal habitat in modern and contemporary environments. The lighting system too, is brand new, which uses LED technology on all its versions.

DE

Das entschiedene und synthetische Design des Millennium ST fügt sich ideal in modern und zeitgenössisch eingerichteten Umgebungen. Neu auch das Beleuchtungssystem aus LED-Technologie, die in allen Modellen zum Einsatz kommt.

FR

Le design décidé et épuré de millennium ST trouve son milieu idéal dans les lieux au style moderne et contemporain. Une autre nouveauté est le système d'éclairage qui s'appuie sur la technologie des leds pour toutes les versions.

ES

El diseño decidido y sintético de Millennium ST encuentra su hábitat ideal en los ambientes de estilo moderno y contemporáneo. Nuevo también el sistema de iluminación que se vale de la tecnología led presente en todas las versiones.





millennium



ENERGY SAVING
LED



INSTALLATION
Plug-in / Remote unit



TEMPERATURE
+1 / +10 °C



DEFROST
Off cycle



CLIMATIC CLASS
3



LX

ST

IL MITO MILLENNIUM NEL MONDO PASTRY





Millennium VG LX 20

MN Millennium

Millennium Pas LX 164

COLORI

PANNELLO FRONTALE / FRONT PANEL / PANNEAU FRONTAL / VORDERPLATTE / PANEL FRONTAL

Finiture laccate / Lacquered finishes / Finitions laquées / Lackiert Vorderplatte / Finitions laquées



Grigio E_Z065



Blu Cielo RAL 5005



Grigio E_Z065



Blu Cielo RAL 5005



Bianco RAL 9003



Orange RAL 2001



Bianco RAL 9003



Orange RAL 2001



Rosso RAL 3020



Lemon RAL 1032



Rosso RAL 3020



Lemon RAL 1032



Beige Perlato RAL 1035



Alluminio RAL 9006

PANNELLO FRONTALE / FRONT PANEL / PANNEAU FRONTAL / VORDERPLATTE / PANEL FRONTAL

Con adesivo / With adhesive / Avec adhésif / Mit Kleber / Con adhesivo



PM_AD1



PM_AD2



PM_AD3

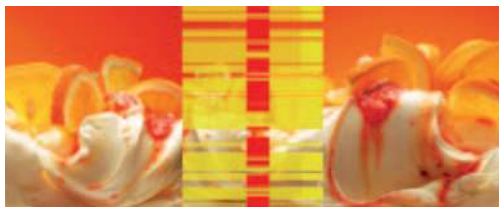

PM_AD5 Orange



PM_AD6 Lemon

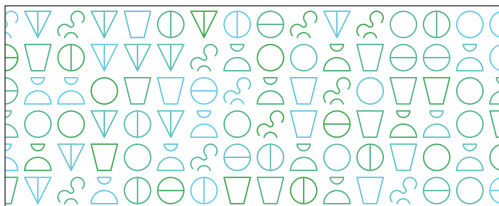

ARIA PM_AD12



Millefiori Bianco

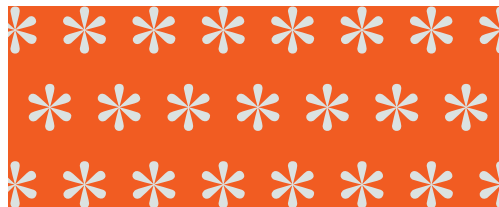

Millefiori Orange

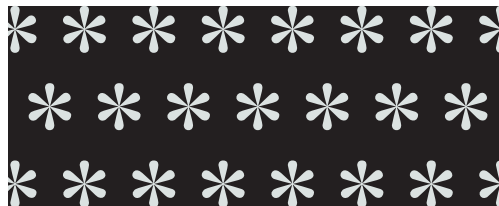

Millefiori Black

FIANCO LATERALE / LATERAL PANEL / PANNEAU LATÉRAL / SEITENPLATTE / PANEL LATERAL

Finiture laccate / Lacquered finishes / Finitions laquées /
Lackiert Vorderplatte / Finitions laquées



Grigio E_Z065

millennium

PLUS



SPECIAL PERFORMANCE /

SPECIAL PERFORMANCE /
SPECIAL PERFORMANCE /
SPECIAL PERFORMANCE /
SPECIAL PERFORMANCE /

- **Sistema di raffreddamento con motorizzazioni potenziato per garantire la classe climatica 7**
- Cooling system with powerful motors 7
- Système de refroidissement à moteurs renforcés 7
- Kühlsystem mit potenzierten Aggregaten 7
- Sistema de refrigeración con motores potenciados 7



ERGONOMIA /

ERGONOMIC /
ERGONOMIE /
ERGONOMIE /
ERGONOMÍA

- **Misure ergonomiche con piano di lavoro arrotondato**
- Ergonomic measurements with rounded worktop
- Mesures ergonomiques avec plan de travail arrondi.
- Ergonomische Maße mit abgerundeter Arbeitsfläche
- Medidas ergonómicas con superficie de trabajo redondeada



VISIBILITÀ /

PRATICITÀ /
PRATICITÉ /
ZWECKMÄSSIGKEIT /
PRACTICIDAD /

- **Segnagusti incorporato nel profilo frontale della vetrina**
- Flavor display incorporated in the showcase molding
- Indicateur de parfum inséré dans le profil de la vitrine
- Im Vitrinenprofil eingefügte Sortenschilder
- Indicador de sabores incorporado en el perfil de la vitrina

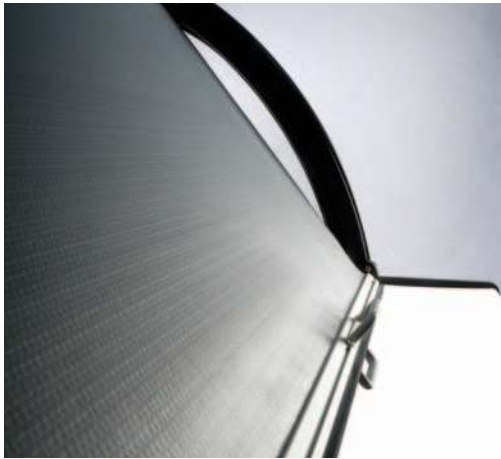

FUNZIONALITÀ /
 FUNCTIONALITY /
 FONCTIONNALITÉ /
 FUNKTIONALITÄT /
 FUNCIONALIDAD

- **Chiusura con tendina autoavvolgente**
- Hidden casters, entirely incorporated into the body
- Fermeture à rideau roulant
- Automatischer Rollladen
- Laterales de los extremos perfectamente alineados con los cristales laterales



VERSATILITÀ /
 RELIABILITY /
 FIABILITÉ /
 ZUVERLÄSSIGKEIT /
 FIABILIDAD

- **Termostato elettronico permette la regolazione del freddo ad uso gelateria e pasticceria**
- Electronic thermostat allows you to adjust for the use of the cold ice cream and pastry
- Thermostat électronique permet de régler l'utilisation de la crème glacée et de pâtisserie
- Elektronischen thermostat können Sie für die Nutzung des kalten Eis und Gebäck einstellen
- Termostato electrónico le permite ajustar para el uso de la crema de helado y pastelería



MOVIMENTAZIONE /
 EASY TO MOVE /
 FACILITÉ DE DÉPLACEMENT /
 LEICHTIGKEIT /
 FACILIDAD

- **Ruote a scomparsa integrate nella scocca**
- Hidden casters, entirely incorporated into the body
- Roulettes escamotables, complètement insérées dans la coque
- Unsichtbare, im Unterbau eingefügte Rollen
- Ruedas ocultas completamente integradas en el chasis



AFFIDABILITÀ /
 RELIABILITY / FIABILITÉ /
 ZUVERLÄSSIGKEIT /
 FIABILIDAD

- **Vasca monoblocco completamente realizzata in acciaio inox**
- One-piece tub made entirely from stainless steel
- Cuve monobloc entièrement réalisée en acier inoxydable
- Monoblock-Wanne aus Edelstahl
- Cuba monobloque completamente realizada en acero inoxidable



RISPARMIO ENERGETICO /
 ENERGY SAVING /
 ÉCONOMIE D'ÉNERGIE /
 ENERGIEEINSPARUNG /
 AHORRO DE ENERGÍA

- **L'isolamento poliuretano spessore 60 mm con agente espandente CO₂ ecologico riduce notevolmente la dispersione del Freddo**
- Polyurethane insulation, 60 mm with ecological CO₂ expanding agent
- Isolation en polyuréthane, de 60 mm à agent d'expansion CO₂ écologique
- 60 mm starke Polyurethan-Isolierung mit niedriger ökologischer Schäumstoff CO₂
- Aislamiento de poliuretano inyectado de 60 mm de espesor, con agente expansor CO₂ ecológico



SICUREZZA /
 RELIABILITY / FIABILITÉ /
 ZUVERLÄSSIGKEIT /
 FIABILIDAD

- **Castello vetri a certificazione CE e UL**
- Glass frame to CE and UL certification
- Cadre en verre à la certification CE et UL
- Glasrahmen nach CE und UL Zertifizierung
- Marco de cristal de la certificación CE y UL

MILLENNIUM / GELATO

		12	16	18	20	24	12+12	
External dimensions (LxDxH) Dimensioni esterne (LxPxH)	LX	1148 x 1062 x 1392 mm	1508 x 1062 x 1392 mm	1678 x 1062 x 1392 mm	1848 x 1062 x 1392 mm	2188 x 1062 x 1392 mm	2188 x 1062 x 1392 mm	
	ST	1143 x 1048 x 1306 mm	1503 x 1048 x 1306 mm	1673 x 1048 x 1306 mm	1843 x 1048 x 1306 mm	2183 x 1048 x 1306 mm	2183 x 1048 x 1306 mm	
	JX	1143 x 1048 x 1306 mm	1503 x 1048 x 1306 mm	1673 x 1048 x 1306 mm	1843 x 1048 x 1306 mm	2183 x 1048 x 1306 mm	2183 x 1048 x 1306 mm	
Capacity (gross/net) Capacità (lorda/netta)		630 / 118 lt	870 / 160 lt	970 / 181 lt	1080 / 201 lt	1300 / 241 lt	1300 / 241 lt	
Net weight Peso netto		235 kg	303 kg	330 kg	348 kg	437 kg	470 kg	
Refrigeration Refrigerazione		Ventilated - Ventilata			Ventilated - Ventilata			
Refrigerant Refrigerante		R404A (1) - R744 (2)			R404A (1) - R744 (2)			
Climatic class Classe climatica		7			7			
Operating conditions Condizioni ambientali		35 °C / 75 %RH			35 °C / 75 %RH			
Cabinet capacity range Temperatura di regolazione		-20/+2 °C			-20/+2 °C			
Product temperature Temperatura prodotto		-16/-14 °C			-16/-14 °C			
Compressor (type) Compressore (tipologia)		1 Hermetic - 1 Ermetico	2 Hermetic - 2 Ermetico	2 Hermetic - 2 Ermetico	2 Hermetic - 2 Ermetico	2 Hermetic - 2 Ermetico	2 Hermetic - 2 Ermetico	
Defrost Sbrinamento		Reverse cycle - Inversione ciclo (1) - Hot gas - Gas caldo (2)			Reverse cycle - Inversione ciclo (1) - Hot gas - Gas caldo (2)			
Power supply Alimentazione		230 V / 1 Ph / 50 Hz			230 V / 1 Ph / 50 Hz			
Electrical input (standard) Assorbimento elettrico		(1) 1650 W / 7,8 A	(1) 1950 W / 8,8 A	(1) 2000 W / 8,9 A	(2) 2500 W / 12 A	(1) 2400 W / 11 A	(1) 3140 W / 15 A	(1) 2850 W / 14 A
Electrical input (defrost) Assorbimento elettrico		(1) 3500 W / 15,6 A	(1) 3990 W / 18 A	(1) 4020 W / 18 A	(2) 2200 W / 13 A	(1) 5000 W / 20,2 A	(1) 5050 W / 20,5 A	(1) 5900 W / 25 A

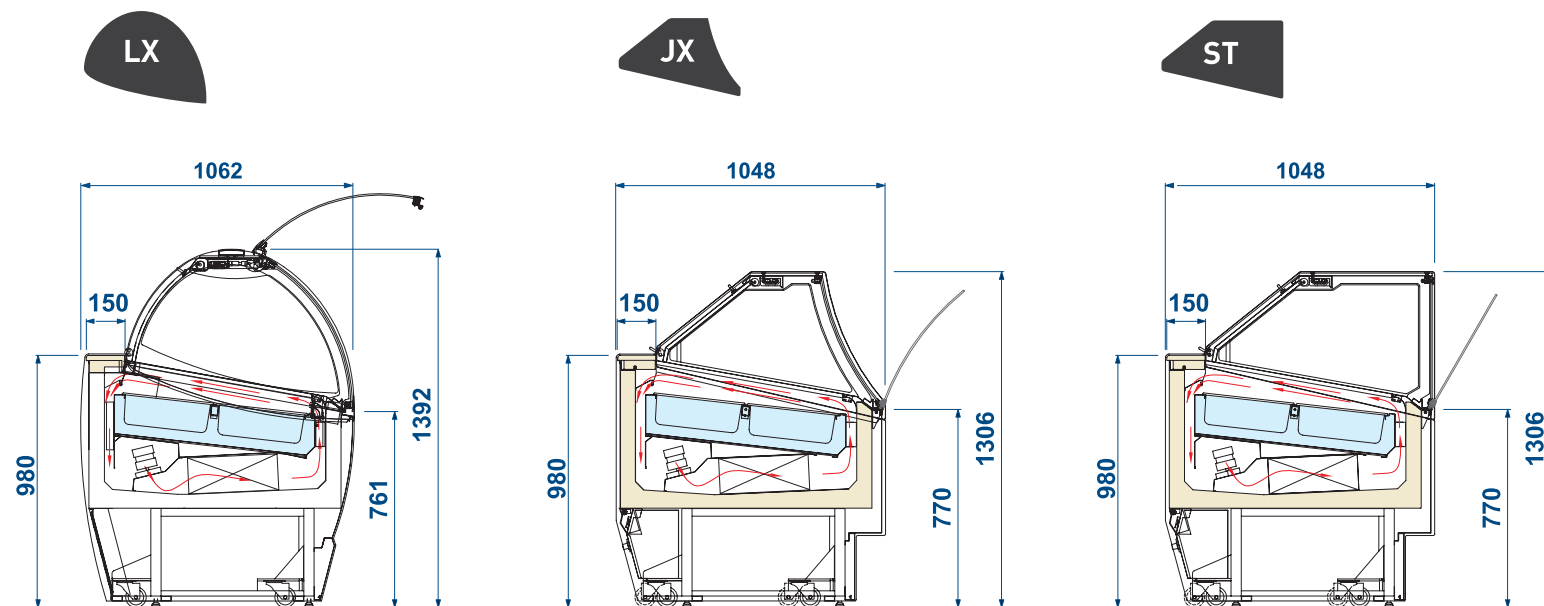

ELEMENTI OPZIONALI / OPTIONALS

		Mod.
Cone holder	Portaconi completo	-
Scoop washer water tap, consolle RX	Lavaporzionate con rubinetto e consolle portaoggetti DX	-
Scoop washer water tap, consolle LX	Lavaporzionate con rubinetto e consolle portaoggetti SX	-
Stainless steel tray V1 2x2 lt 5- 330 x 690 x 100h	Vassoio inox V1 2x2 lt 5- 330 x 690 x 100h	-
Stainless steel tray V2 2x3 lt 5- 495 x 690 x 100h	Vassoio inox V2 2x3 lt 5- 495 x 690 x 100h	-
Wheel kit	Kit ruote	-
Slider	Scorrevoli	12
		16
		18
		20
		24

MILLENNIUM / PASTRY

		110	164	218
External dimensions (LxDxH)	LX	1103 x 1063 x 1393 mm	1643 x 1063 x 1393 mm	2183 x 1063 x 1393 mm
Dimensioni esterne (LxPxH)	ST	1103 x 1048 x 1306 mm	1643 x 1048 x 1306 mm	2183 x 1048 x 1306 mm
Capacity (gross/net)		400 / 150 lt	590 / 220 lt	700 / 300 lt
Capacità [lorda/netta]				
Net weight		235 kg	315 kg	410 kg
Peso netto				
Working length shelves				
Lunghezza utile mensole				
Refrigeration		Ventilated - Ventilata		
Refrigerazione				
Refrigerant		R404A		
Refrigerante				
Climatic class		3		
Classe climatica				
Operating conditions		25 °C / 60 %RH		
Condizioni ambientali				
Product temperature		+1 / +10 °C		
Temperatura prodotto				
Compressor (type)		1 Hermetic - 1 Ermetico		
Compressore (tipologia)				
Defrost		Off cycle - Fermata compressore		
Sbrinamento				
Power supply		230 V / 1 Ph / 50 Hz		
Alimentazione				
Electrical input (standard)		680 W / 4 A	950 W / 5,5 A	1250 W / 6 A
Assorbimento elettrico				
Electrical input (defrost)		360 W / 1,7 A	380 W / 1,8 A	400 W / 1,9 A
Assorbimento elettrico				

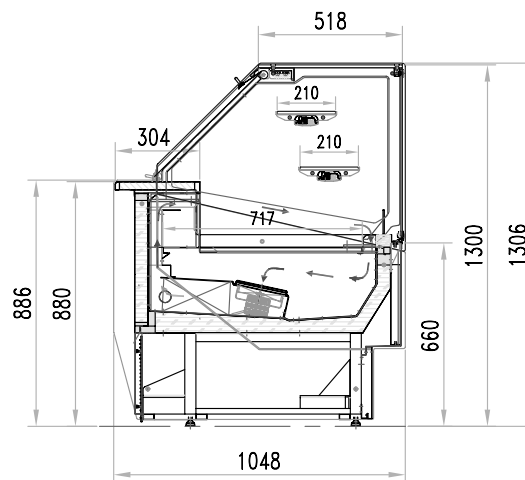
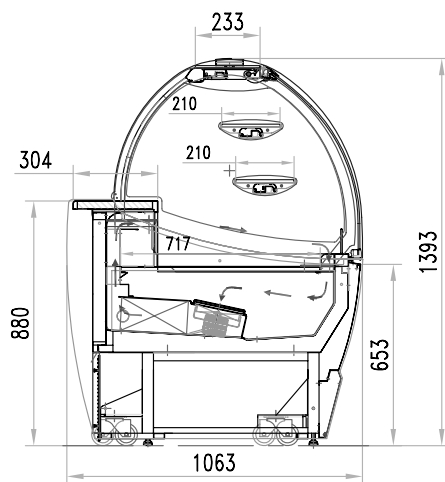

ELEMENTI OPZIONALI / OPTIONALS

Wheel kit	Kit ruote
-----------	-----------



ISA nasce in Umbria, nel cuore di quell'Italia rinomata in tutto il mondo per la sua eccellenza artigiana, industriale e creativa. Con quattro stabilimenti e la presenza in oltre trenta mercati globali ISA è uno dei player al mondo più importanti del mercato dell'arredamento per locali pubblici, delle vetrine e degli armadi refrigerati per gelateria e pasticceria e dell'arredamento professionale.

EN

ISA was established in Umbria, in the heart of Italy, a nation that is famed all over the world for its artisan, industrial and creative excellence. With four sites and the presence in over thirty global markets, ISA is one of the most important players on furniture market for public places, ice cream display cabinets, pastry display cases and professional furniture.

FR

ISA nait en Ombrie, au milieu de cette partie-là d'Italie célèbre dans tout le monde pour son excellence artisanale, industrielle et créative. Avec quatre usines et en étant sur plus de trente marchés globaux, ISA est un des joueurs les plus importants sur le marché international de l'ameublement pour locaux publics, de vitrines et d'armoires d'exposition réfrigérées pour glacerie et pâtisserie et de l'ameublement professionnel.

DE

ISA wurde in Umbrien gegründet, im Herzen Italiens, die in der ganzen Welt für ihre handgefertigte, industrielle und kreative Vorzüglichkeit berühmt ist. Mit vier Werkanlagen und dank der Anwesenheit in mehr als dreißig ISA Global Märkten, ist ISA einer der wichtigsten Player der weltweiten Möbelmarkt für Lokale, Vitrinen und Kühlschränke für Eisdiele und Konditorei und professionelle Einrichtung.

ES

ISA nace en Umbria, en el corazón de una Italia de renombre en todo el mundo por su artesanía, industria y creatividad excelentes. Con cuatro establecimientos y presente en más de treinta mercados globales, ISA es uno de los principales protagonistas mundiales del mercado del mobiliario profesional y de locales públicos así como de los expositores y refrigeradores para heladería y pastelería.

La ISA S.r.l. nell'ambito del continuo miglioramento del prodotto, si riserva il diritto di modificare in qualsiasi momento, senza preavviso, le caratteristiche tecniche ed estetiche dei propri modelli.

In the interest of continual product improvements, ISA S.r.l. reserves the right to make changes in technical specifications and accessories at any moment and without prior notice.



ISO 14064



ISA S.r.l.
via del Lavoro 5
06083 Bastia Umbra PG
Italy
T. +39 075 801 71
F. +39 075 800 09 00
E. customerservice@isaitaly.com

www.isaitaly.com