



FOOD PROCESSING

MACHINES 2016



SIRMAN[®]





COMPANY



Da oltre 45 anni Sirman produce le migliori attrezzature per i Professionisti della Cucina e della distribuzione organizzata.

Dalla prima idea imprenditoriale del fondatore Nereo Marzaro ad oggi, l'azienda si è evoluta costantemente grazie ad una moderna ed efficiente organizzazione interna e ad un team d'eccellenza che opera affinché i prodotti Sirman, interamente progettati e realizzati in Italia, siano presenti in oltre 500 punti vendita nel mercato nazionale e in 125 paesi nel resto del mondo.

Oggi l'azienda è riconosciuta come leader nel settore grazie ad un'ampia gamma di attrezzature, caratterizzate dalla perfetta combinazione di tecnologia e affidabilità, design innovativo e funzionalità, destinate a soddisfare nel migliore dei modi le esigenze di ristoranti, bar, pizzerie, macellerie, salumerie, supermercati, laboratori e industrie alimentari. Un ottimo risultato ottenuto grazie alle brillanti intuizioni dei tecnici e progettisti che, nei laboratori attrezzati con le più avanzate tecnologie, sono impegnati ogni giorno nella ricerca e sviluppo di soluzioni efficaci e innovative per arricchire la gamma già molto ampia dei prodotti Sirman.

Un ufficio tecnico R&D di 12 persone, con 8 stazioni di modellazione solida tridimensionale, gestisce tutte le fasi di studio e progettazione di ogni macchina che esce dai propri stabilimenti produttivi. In contemporanea la forza vendita opera un incessante lavoro di indagine del mercato per individuare i nuovi trend e rimanere sempre sintonizzati sulle reali esigenze dei clienti. Una sinergia di collaborazioni ad altissima professionalità che ha portato Sirman ad affermarsi come l'unico vero partner globale nel mercato italiano e significativa realtà a livello internazionale.

For more than 45 years Sirman has been manufacturing the finest food processing machines for the professional kitchen and retail industry.

From the entrepreneurial idea of the Founder Nereo Marzaro to the present time, Sirman has constantly committed with a high level of organization and teamwork to fulfill the needs of over 500 dealers nationally and 125 countries worldwide with products entirely designed and made in Italy.

Today Sirman is a leader in the industry thanks to the most comprehensive range of food processing machines, designed with a perfect combination of technology and dependability, innovations and solutions to meet and exceed the demands of restaurants, bars, pizzerias, butcheries, supermarkets, laboratories, collectivities and plants. This is the outstanding result of Engineers working every day in high tech departments for the research and development of effective solutions to further expand the line.

The research & development department boasting 12 Engineers with 8 3D modeling stations to manage all stages of the product development process in conjunction to the Sales Force focused on understanding and addressing the rising and ever changing needs of the Customers to create a high-level strategy to be the only global partner in the Italian marketplace and internationally well-recognized.





Sirman ITALIA
Headquarter

Sirman
Factories



SIRMAN ASSEMBLY

Un modernissimo impianto di assemblaggio che precorre i tempi, dotato di magazzino automatizzato da 2.650 posti pallet a servizio dei reparti di assemblaggio che offre flessibilità e velocità ai lanci di produzione orientati sia a ricaricare il magazzino prodotti finiti che alla gestione di produzioni OEM. Il sistema di assemblaggio ad isole specializzate responsabilizza il singolo che segue l'intera fase di assemblaggio. L'esperienza e la perizia del personale permettono di contare su di uno standard qualitativo degno della miglior tradizione meccanica italiana, indispensabile per le affettatrici più prestigiose, piccoli gioielli di raffinata meccanica. L'attenzione alle persone e all'ambiente che contraddistingue da sempre la filosofia di Sirman ha portato a completare questo stabile di 3.200 mq con una installazione fotovoltaica da 50 Kw e un innovativo impianto di riscaldamento a pavimento, che permette alle oltre 40 persone impiegate di lavorare nel massimo comfort anche nei mesi invernali.

An ultra-modern assembly plant of 3.200 m² provided with an automatic storage and retrieval system, capable of 2.650 pallets to ensure availability of material at each stage of the production process, enhance flexibility and production flow for both stock replenishment and OEM custom made product. The assembly system split into dedicated areas for each product raises Sirman Workers' responsibility and confidence during the whole assembly process. At the same time Sirman Workers' skills and expertise qualify for the highest degree of quality, worthy of the finest tradition of Italian mechanics, necessary when it comes to the assembly heavy-duty slicers, genuine masterpieces of refined mechanics. The social responsibility to Employees and the responsibility to the environment and natural resources are vital codes of Sirman mission sustained by the installation of a 50 Kw photovoltaic system and an innovative floor heating system for a safe and comfortable working environment.



SIRMAN TECHNICS

Struttura di 2.700 mq dedicata alle lavorazioni meccaniche su tutte le tipologie dei prodotti Sirman. Orgoglio dell'azienda per organizzazione ed efficienza, il reparto gestisce ben 5 centri di lavoro doppia tavola organizzati in 3 turni di lavoro. Il nuovo reparto pulitura robotizzato che gestisce due bracci Kawasaki e 10 cosiddette "torrette intelligenti" è oggi tra i più avanzati al mondo in grado di offrire risultati perfetti anche senza l'intervento umano. Un lavoro storicamente duro e difficile oggi è diventato agevole e dignitoso grazie agli investimenti operati dall'azienda in automazione e grazie ad un superbo impianto di aspirazione e smaltimento delle polveri.

Sirman takes pride of a highly-efficient 2700 m² metal machining and tooling infrastructure, featuring 5 automatic work centers operating with 3 shifts a day. The new robotic polishing system provided with two Kawasaki robots and 10 different matrix styles is today one of the most advanced worldwide able to achieve perfect results without human interaction. Metal polishing is notoriously a hard and unhealthy work, made easy and secure by Sirman thanks to the investments in automation and a state of the art powder and residues extraction and disposal system.



ITALCENTRO

6.000 mq divisi in 3 reparti produttivi separati che gestiscono: il primo la produzione di vetrinette, piastre ad induzione e vari altri apparecchi per la cottura, il secondo tutte le macchine bar e i frullatori ad immersione, il terzo piastre grill, tostiere e forni pizza. Quest'ultimo autosufficiente anche per la produzione e finitura dei lamierati in acciaio inox.

6.000 m² split into 3 production areas. One area has been dedicated to the production of food displays, induction hobs and other modern cooking products, the second one to the production of all bar and beverage machines and immersion blenders, finally the third one is provided with a machining center for stainless steel for the production of panini contact grills, toasters and pizza ovens.



Sirman USA
Chicago



Sirman China
Shanghai

Oggi Sirman vanta dieci unità produttive, tutte rigorosamente in terra Veneta all'insegna del miglior 'Made in Italy', e due sedi commerciali estere con magazzino e assistenza, di cui una a Chicago dal 1999 e una a Shanghai dal gennaio 2005.

Nella sede centrale si trovano il magazzino spedizioni, il controllo qualità, gli uffici e il reparto ricerca e sviluppo che conta su 8 stazioni di modellazione solida tridimensionale per seguire lo sviluppo e la messa in produzione di tutti i prodotti dell'azienda.

Today Sirman boasts ten manufacturing facilities, proudly located in the Veneto area for the best Made in Italy products, a Chicago branch office since 1999 and a Shanghai one since 2005, both provided with a stocking warehouse and service to better serve the US and Chinese market.

The Headquarters host the shipping & receiving department and the research & development department disposing of 8 3D modeling stations to manage all stages of the product development process.



SIRMAN 3

Ultimo nato tra i reparti produttivi di Sirman, quello dedicato alla produzione delle macchine sottovuoto. Prodotto in forte crescita numerica e sviluppo di gamma nel pacchetto Sirman che sta dando ottime soddisfazioni e risposte dal mercato.

The newest production facility of Sirman, dedicated to the production of vacuum pack machines. This product further expands Sirman line achieving outstanding results in customer satisfaction.



PIAZZOLA 1

Dedicato alla produzione di macchine per la preparazione dinamica in cucina, quali pelapatate, tagliaverdure e puliscicozze. Un reparto di soli 1.000 mq che sforna grandi numeri grazie alla sua focalizzazione sui prodotti che hanno introdotto Sirman nelle cucine di tutto il mondo.

Dedicated to the production of food preparation machines such as potato peelers and continuous-feed food processors. An area of just 1.000 m² with an extremely high production yield focusing on products which have made Sirman a renowned name inside the professional kitchens all over the world.



PIAZZOLA 2

Ben strutturato ed efficiente il reparto di produzione macchine lavorazione carni conta su 2.200 mq di spazio, dove 5 isole di assemblaggio sfornano macchine dalle grandi prestazioni, ponendo particolare attenzione alle esigenze dei singoli mercati e, spesso, anche dei singoli clienti. Una struttura dove i numeri lasciano lo spazio ad una maggiore attenzione alle specificità richieste per questa tipologia di prodotto, dove affidabilità, performance e resistenza agli ambienti più duri, sono diventate le linee guida per lo sviluppo di sempre nuovi prodotti e soluzioni.

The highly efficient facility of 2.200 m² destined to the production of meat processing machines features 5 assembly areas capable of producing high-performance machines in accordance to the particular needs of a marketplace or even a single account. Accuracy and care prevail over yield for the development and implementation of dependable, performing and durable products and solutions.

Showroom



Corsi di aggiornamento - Seminars



Fiere - Exhibitions



Sirman è sempre al passo con i tempi, con le nuove tendenze ristorative, con le più innovative tecnologie e, soprattutto, con le esigenze dei migliori professionisti della cucina. Per essere sempre aggiornata e offrire soluzioni in piena sintonia con un mercato in continua evoluzione, l'azienda investe ogni anno molte risorse nella formazione del suo team e nella comunicazione a 360° del mondo Sirman, per raccontarne tutte le sue numerose e importanti sfaccettature. L'azienda, infatti, crede fortemente nell'importanza di far conoscere la qualità dei propri prodotti perché solo in questo modo i suoi clienti possono comprendere i vantaggi che i nuovi sistemi portano al lavoro di tutti i giorni per sfruttarne al massimo le potenzialità ed esprimere al meglio la qualità del loro lavoro. Perché è proprio la qualità del lavoro di chi opera in cucina da professionista che Sirman vuole valorizzare e promuovere con tutti i mezzi a sua disposizione: con la sponsorizzazione di eventi di successo che vedono come protagonista la Nazionale Italiana Cuochi e brillanti rappresentanti del mondo del 'cooking and beverage', con un ampio ventaglio di corsi e seminari di formazione tenuti da tecnici del settore, con importanti opere nell'ambito dell'editoria come la pubblicazione di ricettari di chef rinomati, materiali multimediali e con la rivista Zafferano magazine, dedicata interamente ai Professionisti della ristorazione e della gastronomia con articoli e approfondimenti curati dai maggiori esperti del settore.

Sirman stays updated with the new food service trends, the most innovative technologies and the demands of the finest Chefs. To do so and provide solutions to an ever changing market place, Sirman values training and development of the Workforce and a comprehensive corporate communication to emphasize a considerable amount of important activities. It is extremely important indeed to acknowledge the quality of the products as it is the only way for Customers to understand the daily advantages of new solutions and fully express skills and abilities. Sirman intends to promote the quality work of Professionals by means of event sponsorships for the Italian culinary team and famous personalities of the culinary world, classes and seminars conducted by industry Experts, publications of recipe books from world-renowned Master Chefs, multimedia and the Zafferano magazine, entirely dedicated to the food service and culinary Professionals with insights from the finest culinary experts.

Sponsor ufficiale di:



Equipe Cuochi Veneto



Web Site



Magazine di ristorazione e gastronomia
Magazine of catering and gastronomy



Pubblicazioni specializzate - Literature



Materiale multimediale - Multimedia support

TECHNOLOGY

SIRMAN TRACK www.sirmantrack.com

E' una piattaforma integrata tra ambiente web e mobile che permette di gestire il post vendita di un parco macchine installato.

Velocizza le chiamate di servizio, tramite invio automatici di SMS ai tecnici, agevola la stesura dei rapportini di riparazione, traccia tutti gli interventi e i relativi costi di ogni macchina sottoposta a controllo. Un grande aiuto per chi, come Sirman, fa dell'assistenza il suo punto di forza.

Sirman takes the after-sale service to the next level of customer satisfaction thanks to the innovative Sirmantrack, a web-based platform integrated with web and mobile.

Easier management of service calls through SMS text messages and service bulletin-filling process, keeping track of all calls and costs for each unit.

A great help for those, like Sirman, who make the after-sale service their strength.

SIRMAN RCS Remote Control System

Il telecontrollo, tecnologia dedicata normalmente agli impianti industriali o a situazioni che devono gestire contenuti di grandi valore, entra grazie a Sirman, anche negli apparecchi per il food processing.

Il software proprietario e la tecnologia hardware adottata in esclusiva da Sirman permettono, con costi decisamente contenuti, di avere sotto controllo sempre e in ogni momento un parco macchine installato, con evidenti vantaggi nella gestione economica ed energetica.

Usually employed for industrial equipment and critical business activities, the remote control technology now enters the food processing equipment industry as well thanks to Sirman. With a proprietary software, an exclusive hardware and minimum costs, SirmanRCS allows for the complete control of a installed set of equipment with significant management and energy-saving advantages.





ONLY FOR PROFESSIONALS





FAC TO RY





Tutto il processo produttivo avviene all'interno dell'azienda. Anche gli ultimi investimenti realizzati dimostrano quanto Sirman punti sulla produzione interna più che sulla dislocazione della produzione nel Far East. Nel 2008 sono entrati in funzione il nuovo magazzino spedizioni con 9 baie di carico e il reparto di controllo qualità con 7 nastri trasportatori dove vengono preparate e testate le macchine prima dell'imballaggio e spedizione. Il 2009 ha visto partire il quinto centro di lavoro automatico doppia tavola e il nuovo sistema di pulitura robotizzata con 2 antropomorfi che assorbono il 98% di un lavoro duro e impegnativo. Ma, ulteriore passo in avanti dell'azienda verso una migliore organizzazione del lavoro e una maggiore efficienza, è il nuovo magazzino robotizzato, a servizio della produzione e con capienza di 2650 pallet, totalmente integrato con il sistema ERP aziendale e che distribuisce i componenti alle varie isole di assemblaggio: un sistema unico nel settore per velocizzare e rendere ancora più flessibile la produzione interna. Tutti investimenti importanti, questi, destinati a strutturare e ottimizzare il sistema produttivo.

The entire manufacturing process is developed in our factories. The latest investment activities indeed contribute to a lean and effective production system and do not give rise to outsourcing of production to the Far East.

In 2008 a new shipping and receiving department has been fully operative with 9 loading docks and 7 power and QC test stations powered by conveyor belts to better coordinate and speed up the equipment packaging process.

In 2009 it was the turn of the 5th automatic work center and the new robotic polishing system for polishing off the parting lines of components without the labor intensive efforts required with manual systems.

A further step ahead of Sirman has been the automatic storage and retrieval system integrated with the company ERP and capable of 2650 pallets to ensure availability of material at each stage of the production process, thus avoiding bottlenecks and enhancing efficiency.





Grazie alla sua brillante équipe tecnica, alle dieci unità produttive supportate da un'affidabile rete di subfornitori e ad un rigoroso sistema di collaudo, l'azienda controlla direttamente ogni fase, dalla progettazione alla realizzazione, dalla lavorazione della lamiera per passare alla modellazione dei singoli pezzi e al montaggio degli stessi, fino ai test di controllo di validità del prodotto e alla consegna del prodotto finito. Un processo complesso che mette in gioco forza lavorativa, conoscenze specialistiche di settore, grande precisione nel portare a termine ogni step dell'intera catena produttiva e un lavoro di team molto articolato e strutturato per garantire la massima organizzazione ed elevati standard di qualità su tutti i suoi prodotti marchiati Sirman.

A talented engineering department, ten production facilities backed by a reliable supply chain and a rigorous test system enable Sirman to control each production stage from planning to implementation: from material machining to the assembly process up to the quality control and delivery of the end product to the Customer. That's a challenging process involving a specialized workforce, skills and accuracy in conjunction with an interdependent teamwork to ensure the highest quality standards and gain the necessary competitive advantage.





16 AFFETTATRICI slicing machines

22	Anniversario 300
24	Anniversario LX 350
30	Canova
31	Canova Automec
39	Galileo Evo
42	Galileo Evo Power
44	Giotto
50	Leonardo Evo
46	Mantegna
29	Mirra
43	Mirra Verticale
32	Palladio
34	Palladio Automec
35	Palladio Evo Usa
38	Palladio/Galileo Stonehenge
36	Raffaello
26	Smart
48	Tiziano
28	Topaz

54 RISTORAZIONE food processors

70	Athos
67	Blitz
72	Ciclone
62	Como
56	Concerto - Sinfonia
68	Cutter
90	Dolomiti
81	GF Dakota
80	GF Vegas - GF Denver
82	GFX - GF
79	GP-GF
93	MCF - MPF
76	PPJ - LCJ
77	PPJ SC - LCJ SC
63	Sansone
60	Sirpasta Maxi
57	Sirpasta Y15
71	Storm
89	TC 12-22 Dakota
87	TC 12E-22E
89	TC 8 Vegas - TC 12 Denver
85	TCG 12-22 Dakota
83	TCG 12E-22E
84	TCG 8 Vegas - TCG 12 Denver
64	TM2
66	TM-TG
73	Vortex

94 lavorazione CARNE meat processors

133	Ceppi-Tavoli-Piani
131	Drake
111	Format
122	IDRA 15-25-35-50
114	IP 10-20 M
115	IP 30-50 M Y14
116	IP 50-120 M-B
117	IP 50-80-120-180 XP BA
121	IS 16-30-50 Idr. Oriz.
120	IS 8-16 Aries
119	IS 8-16 X - IS 12 VX
113	Katana 20
112	Katana 6-12
108	Master
130	SA
124	SO Alluminio
125	SO Bremen
126	SO Inox
128	Sterilizzatori elettrico e a liquido
129	Sterilizzatori UV
98	TC 22-32 Barcellona
100	TC 22-32 Barcellona Hamburgatrice
99	TC 22-32 Barcellona ICE
96	TC 22-32 Colorado
101	TC 22-32 Nevada
102	TC 22-32 Nevada ICE
97	TC 32 California
104	TC Buffalo
106	TC Montana
132	T-Rex / T-Rex Automec

134 macchine IMBALLAGGIO packaging machines

143	Dispenser
137	Easyvac 25
136	Sigix M20
138	W8 30-40-50-70

144 macchine COTTURA cooking machines

153	Aliseo
154	Basic - Fissa - Pro
146	Easysoft
155	Pl. 2,5 - 3,5
148	Softcooker S - SR
150	Softcooker Wi-Food
152	Softcooker Y09

156 SNACK e PIZZA

snack and pizza

166	4Q - 6Q- 12Q
159	Cort
164	Cort V. - PD V. - Top V.
163	Crepiere
158	Elio
184	Forno pizza
175	GW
180	Hercules 20-30-40-50
178	Hercules 5-10-15
176	Hot dog - Roberto
173	Night & Day
160	PD
161	PD Power
165	PD VC
182	Piastre scaldapizza
191	Pizza
186	Stromboli
162	TOP
168	Tosti - Breakfast - Long - Bruschetta
167	Tostone
177	TW
188	Vesuvio
183	Vetrinette D. 38-42
170	Vista
171	Vista Bold
174	Vista Easycold
172	Vista Tower
187	Vulcano

192 linea BAR

bar line

202	Apollo
200	Barmaster
196	Dragone
209	Ice spaghetti/Spremiagrumi manuale
203	Mercurio
206	Modulo
208	Multiplo
205	Nordkapp
198	Orione
197	Saturno
194	Sirio
204	Triton

210 distribuzione ESCLUSIVA

exclusive distribution

229	45K
248	Carrelli / Trolley
244	Ektor 37
236	Eldorado
230	HW 45
239	Forcella
230	HW 45
218	IH 27 - IH 35 - IH 35 Wok - PI 5.0 Kw
243	Kiro
242	Minicooker - Mycook
214	Minneapolis 10-20-30-40
215	Minneapolis 5
232	Ortolina
216	Pacojet
238	Pasti
219	PB 1/1 Inox
234	Plutone 7-10-20-30
231	S 300/2 - S 400/2 - S 400/2T
249	SAR-C 447E
212	Scharfen
233	SmokerBag - Tegi
246	Salento-Soave-Monferrato-Colli Orientali
240	SP 310 - 420
	Panasonic
223	1/1 Gastronorm
224	1/2 Gastronorm
222	NE 1027-1037-1037 Self
226	NE C1475
221	NN CF771 S
220	SR-42GHXN - SR-UH36N
	Minneapolis
228	WDB 900 COMBI-WP 1000PF-CM1039A
	Samsung
250	WF 431 ABP
251	DV 431 AEP

AFFETTATRICI

Da sempre prodotto di punta della proposta Sirman, le affettatrici, progettate dalla professionalità e competenza di un Ufficio Tecnico all'avanguardia, sono disponibili in una gamma di rara completezza.

A caratterizzare gli innumerevoli e differenti modelli lanciati sul mercato sono i materiali altamente selezionati usati per realizzarli, una funzionalità ad altissima tecnologia, una totale affidabilità in fatto di pulizia e sicurezza - garantita dalla piena fedeltà alle più rigorose norme di sicurezza elettromeccanica e alimentari - e, non da ultimo, un design capace di unire classico e moderno in un'inimitabile armonia di linee e forme. In continua evoluzione per soddisfare le specifiche esigenze di tutti i settori, le affettatrici firmate Sirman costituiscono oramai un fondamentale punto di riferimento nel mercato internazionale del food processing.

SLICING MACHINES

Slicing machines have always been one of Sirman's front-line products, fine-adjusted by the professional expertise and competence of an avant-garde Technical Office, and available in a remarkably varied range. The great variety of different models launched on the market is characterized by the carefully-selected materials used in their making, by a practicality stemming from a very high technological content, and from a total reliability as regards cleaning and safety - guaranteed by full compliance with the strictest standards relating to food processing - and, last but not least, a design capable of combining classic and modern in an inimitable harmony of lines and forms. In constant evolution to satisfy the specific needs of all sectors, the Sirman slicing machines have become a fundamental reference on the international food processing market.



CARATTERISTICHE COMUNI A TUTTE LE AFFETTATRICI

SPECIFICHE AFFETTATRICI - COMMON FEATURES IN ALL SLICERS

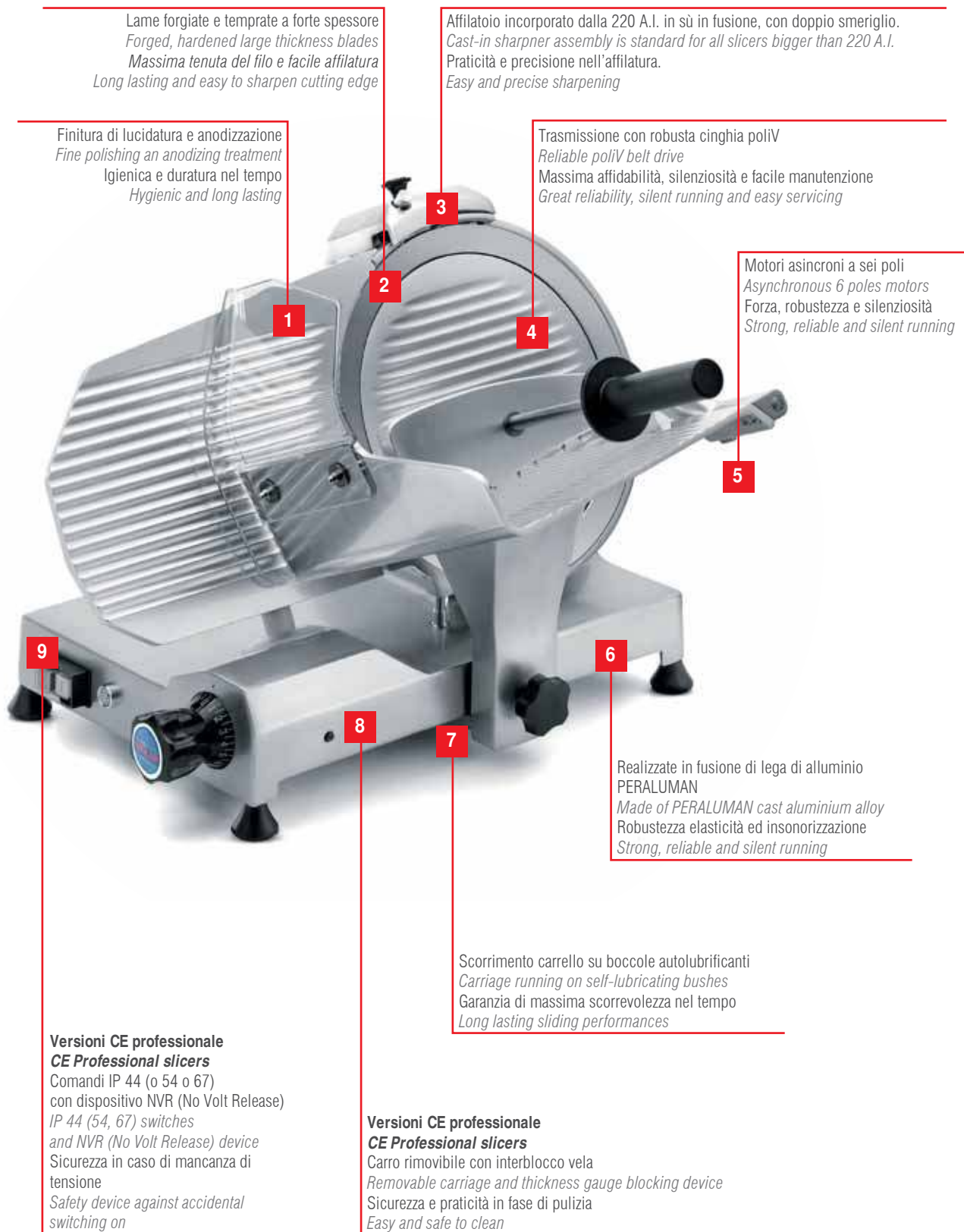

Lame forgiate e temprate a forte spessore
Forged, hardened large thickness blades
Massima tenuta del filo e facile affilatura
Long lasting and easy to sharpen cutting edge

Affilatoio incorporato dalla 220 A.I. in sù in fusione, con doppio smeriglio.
Cast-in sharpener assembly is standard for all slicers bigger than 220 A.I.
Praticità e precisione nell'affilatura.
Easy and precise sharpening

Finitura di lucidatura e anodizzazione
Fine polishing and anodizing treatment
Igienica e duratura nel tempo
Hygienic and long lasting

Trasmissione con robusta cinghia poliV
Reliable poliV belt drive
Massima affidabilità, silenziosità e facile manutenzione
Great reliability, silent running and easy servicing

Motori asincroni a sei poli
Asynchronous 6 poles motors
Forza, robustezza e silenziosità
Strong, reliable and silent running

Realizzate in fusione di lega di alluminio
PERALUMAN
Made of PERALUMAN cast aluminium alloy
Robustezza elasticità ed insonorizzazione
Strong, reliable and silent running

Scorrimento carrello su boccole autolubrificanti
Carriage running on self-lubricating bushes
Garanzia di massima scorrevolezza nel tempo
Long lasting sliding performances

Versioni CE professionale
CE Professional slicers
Comandi IP 44 (o 54 o 67)
con dispositivo NVR (No Volt Release)
IP 44 (54, 67) switches
and NVR (No Volt Release) device
Sicurezza in caso di mancanza di
tensione
Safety device against accidental
switching on

Versioni CE professionale
CE Professional slicers
Carro rimovibile con interblocco vela
Removable carriage and thickness gauge blocking device
Sicurezza e praticità in fase di pulizia
Easy and safe to clean

AMBIENTE DI UTILIZZO

USE DESTINATION

	Domestico Household	Bar Bar and pubs	Snack	Fast Food	Piccola pizzeria Small pizza-restaurant	Piccolo ristorante Small restaurant	Ristorante Restaurant	Grosso ristorante Big restaurant	Catering Catering business	Comunità Canteens	Salumeria Grocery	Macelleria Butchery	Supermercato Supermarket	Industria Industry
SMART - TOPAZ	Green	Green	Green											
MIRRA	Green	Green	Green	Green	Green	Green								
CANOVA		Green	Green	Green	Green	Green								
PALLADIO/RAFFAELLO							Green	Green	Green	Green				
GALILEO							Green	Green	Green	Green	Green	Green	Green	Green
GALILEO INGRANAGGI							Green	Green	Green	Green	Green	Green	Green	Green
GALILEO AUT							Green	Green	Green	Green	Green	Green	Green	Green
MIRRA VERTICALE		Green	Green		Green	Green								
GIOTTO		Green	Green		Green	Green	Green							
MANTEGNA/TIZIANO				Green	Green	Green	Green	Green	Green	Green	Green	Green	Green	Green
LEONARDO				Green	Green	Green	Green	Green	Green	Green	Green	Green	Green	Green

PRODOTTO

PRODUCT

	Pane Bread	Formaggio Cheese	Verdura Vegetable	Salami Sausages	Prosciutto cotto Cooked ham	Prosciutto crudo disossato Boneless parma ham	Prosciutto crudo con osso Parma ham with bone	Carne fresca Fresh meat	Carne cotta Cooked meat	Carne congelata (-1°) Frozen meat (-1°)	Pesce Fish
SMART - TOPAZ	Yellow	Yellow	Green	Green	Green	Yellow	Red	Yellow	Green	Red	Yellow
MIRRA	Yellow	Yellow	Green	Green	Green	Yellow	Red	Yellow	Green	Red	Yellow
MIRRA 300	Yellow	Yellow	Green	Green	Green	Yellow	Red	Yellow	Green	Red	Yellow
CANOVA	Yellow	Yellow	Green	Green	Green	Yellow	Red	Yellow	Green	Red	Yellow
PALLADIO /RAFFAELLO	Yellow	Yellow	Green	Green	Green	Yellow	Red	Yellow	Green	Red	Yellow
GALILEO - GALILEO INGR.	Yellow	Yellow	Green	Green	Green	Yellow	Red	Yellow	Green	Red	Yellow
GALILEO AUT.	Yellow	Yellow	Green	Green	Green	Yellow	Red	Yellow	Green	Red	Yellow
MIRRA VERTICALE	Yellow	Yellow	Green	Green	Green	Yellow	Red	Yellow	Green	Red	Yellow
GIOTTO BS	Yellow	Yellow	Green	Green	Green	Yellow	Red	Yellow	Green	Red	Yellow
GIOTTO VCS	Yellow	Yellow	Green	Green	Green	Yellow	Red	Yellow	Green	Red	Yellow
MANTEGNA - TIZIANO BS	Yellow	Yellow	Green	Green	Green	Yellow	Red	Yellow	Green	Red	Yellow
MANTEGNA - TIZIANO VCS	Yellow	Yellow	Green	Green	Green	Yellow	Red	Yellow	Green	Red	Yellow
LEONARDO BS	Yellow	Yellow	Green	Green	Green	Yellow	Red	Yellow	Green	Red	Yellow
LEONARDO VCS	Yellow	Yellow	Green	Green	Green	Yellow	Red	Yellow	Green	Red	Yellow

- Green Consigliata per l'uso Suggested for this use
- Yellow Utilizzabile ma non ideale Usable for this food but not ideal
- Red Sconsigliata Not recommended for this use

TIPO DI LAMA

TYPE OF BLADE

	Pane Bread	Formaggio Cheese	Verdura Vegetable	Salami Sausages	Prosciutto cotto Cooked ham	Prosciutto crudo disossato Boneless parma ham	Prosciutto crudo con osso Parma ham with bone	Carne fresca Fresh meat	Carne cotta Cooked meat	Carne congelata / 2° Frozen meat / 2°	Pesce Fish
Standard cromata Chromed	Yellow	Yellow	Green	Green	Green	Green	Green	Green	Green	Green	Green
Standard teflonata Teflonated	Yellow	Green	Yellow	Yellow	Yellow	Yellow	Yellow	Yellow	Yellow	Yellow	Green
Dentata cromata Toothed chromed	Green	Green	Red	Yellow	Red	Red	Red	Red	Yellow	Green	Yellow

- Green Consigliata per l'uso Suggested for this use
- Yellow Utilizzabile ma non ideale Usable for this food but not ideal
- Red Sconsigliata Not recommended for this use

VERSIONI AFFETTATRICI

SLICERS VERSIONS

AFFETTATRICI BASIC

BASIC SLICERS



1 - Protezione inferiore
Underside motor protection plate

AFFETTATRICI CE DOMESTICO

CE DOMESTIC SLICERS



1 - Paramano piatto in plexiglass
Plexiglass hand guard
2 - Elsa su manopola pressamerce
Grip on the meat press knob
3 - Microinterruttore su paralama
Micro on blade cover
4 - Protezione inferiore
Underside motor protection plate

AFFETTATRICI CE PROFESSIONALE

CE PROFESSIONAL SLICERS



1 - Paramano piatto in plexiglass
Plexiglass hand guard
2 - Elsa su manopola pressamerce
Grip on the meat press knob

3 - Microinterruttore su paralama
(escluso affettatrice Ingranaggi)
*Micro on blade cover
(Not available on Ingranaggi series slicers)*
4 - Pulsantiera elettronica o dispositivo similare
Electronic switch or similar device

5 - Anello protezione lama
Blade protection ring

6 - Estrattore per lama
Blade removal tool

7 - Meccanismo sgancio piatto affettatrice
Device for releasing the carriage

8 - Protezione inferiore
Underside motor protection plate

COMANDI CONTROLS



Interruttore standard - isolato IP44
Standard switch - protection class IP44
Affettatrici Basic e affettatrici UL
Slicers Basic and slicers UL



Interruttore rotativo UL - isolato IP42
Rotative switch UL - protection class IP42
Affettatrici Basic con lama 300 o maggiore
Slicers Basic with blade 300 or bigger



Interruttore CE professionale - isolato IP44
CE Professional switch - protection class IP44
Affettatrici Smart, Mirra 220-300, Mirra Vert. 275-300, Canova e Giotto
Slicers Smart, Mirra 220-300, Mirra Vert. 275-300, Canova and Giotto



Pulsantiera Opera - isolata IP54 (pulsanti IP67)
Opera electronic switch - protection class IP54 (push-buttons IP67)
Affettatrici CE Palladio, Raffaello, Galileo, Mantegna, Tiziano e Leonardo
Slicers CE Palladio, Raffaello, Galileo, Mantegna, Tiziano and Leonardo



Pulsantiera Sidney - isolata IP54 (pulsanti IP67)
Sidney electronic switch - protection class IP54 (push-buttons IP67)
Affettatrice CE Canova Top e Giotto Top
Slicer CE Canova Top and Giotto Top



Comandi su carcassa (pulsanti IP67)
Controls on body (push-buttons IP67)
Affettatrici CE Palladio Top, Raffaello Top, Galileo Top, Mantegna Top, Tiziano Top e Leonardo Top
Slicers CE Palladio Top, Raffaello Top, Galileo Top, Mantegna Top, Tiziano Top and Leonardo Top



Pulsantiera Sirman - isolata IP54
Sirman push-button panel - protection class IP54
su richiesta
on request

VERSIONI SPECIALI SPECIAL VERSIONS



Paramano piatto in plexiglass
Plexiglass hand guard



Interruttore rotativo
Rotative switch



Protezione inferiore
Underside motor protection plate



ANNIVERSARIO 300



- Fusione in alluminio smaltata.
- Particolari in acciaio inox e alluminio anodizzato argento.
- Lama 300.
- Sistema brevettato di movimentazione (senza componenti meccanici in vista).
- Braccio blocca salumi BS1.
- Facile posizionamento del piatto scorrevole.
- Ergonomia, scorrevolezza e praticità di pulizia.
- Carro completamente smontabile per la pulizia.

- 300 mm (12") blade Flywheel slicer.
- Polished and painted aluminum construction.
- Featuring stainless steel and silver anodized aluminum details.
- Patented motion system with no visible mechanical parts.
- Table featuring a lateral movement with a double articulating arm BS1 to firmly hold and smoothly slide the produce through.
- Removable carriage for ease of cleaning.
- Simple, yet stylish Italian design, rounded for ease of cleaning.
- The only one featuring a removable carriage.
- Easy to clean and disassemble without tools.



1. Facile da smontare e pulire
Easy to disassemble and clean

XL 300



2. Piedistallo opzionale - disponibile nero o rosso
Optional stand - red or black available

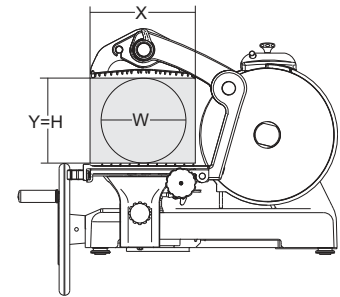
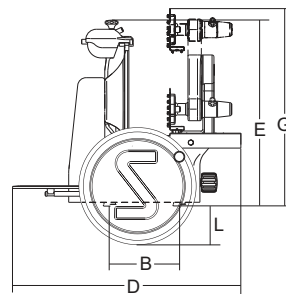
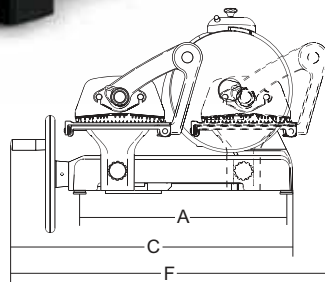

	Ø Lama Ø Blade Ø Messer Ø Lame	Spessore taglio Cut thickness Schnittbreite Epaisseur de coupe	Corso carrello Run or carriage Wagenschub Course du chariot	Piatto Hopper Wagen grosse Plateau	A	B	C	D	E	F	G	L	X	Y	H	W	Peso netto Net weight Nettogewicht Poids net	Dimensioni imballo Shipping Verpack. abmessungen Dmr. emballage	Peso lordo Gross weight Bruttogewicht Poids brut
	mm/inch.	mm	mm	mm	mm	mm	mm	mm	mm	mm	mm	mm	mm	mm	mm	kg	mm	kg	
Anniversario 300	300/12"	0-3	285	270x295	520	180	770	625	510	855	590	90	270	200	200	200	60	960x920x860	78
XL 300	300/12"	0-3	285	270x295	520	180	770	625	510	855	590	90	270	200	200	200	60	960x920x860	78
	Ø Cuchilla Ø Lámina Ø лезвья 刀片直径	Esponsor corte Espesura corte Толщина напески 切削厚度	Desplazamiento del carro Escorrimiento carrinillo Ход вагончика 料斗行程	Piatto Plato Лоток 料斗	A	B	C	D	E	F	G	L	X	Y	H	W	Peso neto Peso líquido Бесчистый вес 净重	Dimensiones embaleaje Dimensões embalgem Пакемаля yмакоеки 包装尺寸	Peso bruto Peso bruto Бесчистый вес 毛重



ANNIVERSARIO LX 350



- Anniversario LX: un connubio di eleganza classica e funzionalità moderna.
- Sapiente fusione di stile ed ergonomia, praticità e buon gusto, funzionalità ed esclusività.
- Una poesia di linee, luci, colori e meccanica, la più pura, semplice, funzionale... Un vero sogno!
- Costruzione in fusione di ghisa sferoidale.
- Particolari in alluminio anodizzato argento.
- Braccio stringisalumi monoblocco.
- Pressamerce smontabile in acciaio inox.
- Carro smontabile per la pulizia.

- *Anniversario LX: a perfect mix of classical elegance with modern functionality.*
- *Fusion of style and ergonomics, easy use and good taste, practical and exclusive.*
- *A poem of lines, lights, colours and technics, pure, simple and durable technics... A real dream!*
- *Solid cast iron construction epossidic painted.*
- *Carriage and other details made of anodized aluminium alloy.*
- *Self adjusting blocking arm with stainless steel removable pushern.*
- *Carriage easy to remove.*



Colori opzionali:
Optional colors:

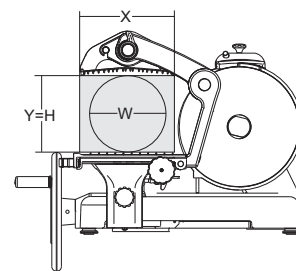
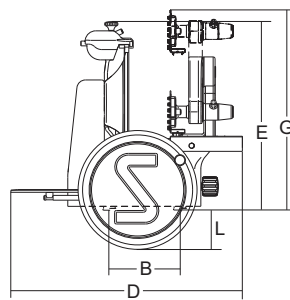
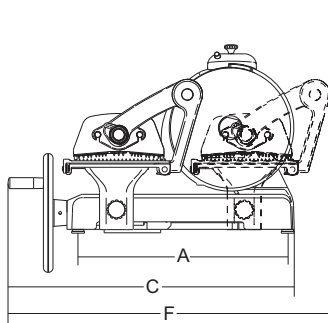

Ø Lama
Ø Blade
Ø Messer
Ø Lame
Spessore taglio
Cut thickness
Schnitttiefe
Épaisseur de coupe

Corso carrello
Run or carriage
Wagenschub
Course du charriot

Plato
Hopper
Wagen grösse
Plateau

A B C D E F G L X Y H W

Peso netto
Net weight
Nettogewicht
Poids net
Dimensioni imballo
Shipping
Verpack abmessungen
Dim. emballage

Peso lordo
Gross weight
Bruttogewicht
Poids brut

LX 350	mm/inch.	mm	mm	mm	mm	mm	mm	mm	mm	mm	mm	mm	mm	mm	mm	kg	mm	kg	
	350/14"	0-3	345	320x350	592	180	820	780	560	910	615	120	330	255	255	255	72	960x920x860	90

Ø Cuchilla
Ø Lâmina
Ø нож
刀片直径
Espesor corte
Essencia corte
Толщина нарезки
切削厚度

Desplazamiento del carro
Escorrimiento carrinho
Ход каретки
料斗行程

Plato
Prato
Лоток
料斗

A B C D E F G L X Y H W

Peso neto
Peso líquido
Вес нетто
净重
Dimensiones embalaje
Dimensões embalagem
Размеры упаковки
包装尺寸

Peso bruto
Peso bruto
Вес брутто
毛重



1. BS2 braccio speciale monoblocco
BS2 self adjusting blocking arm



2. Ampio spazio tra lama e corpo
More space between blade and
body machine



3. Zavorra braccio speciale
Food pusher blocking arm



4. Protezione lama rimovibile
Removable blade protection

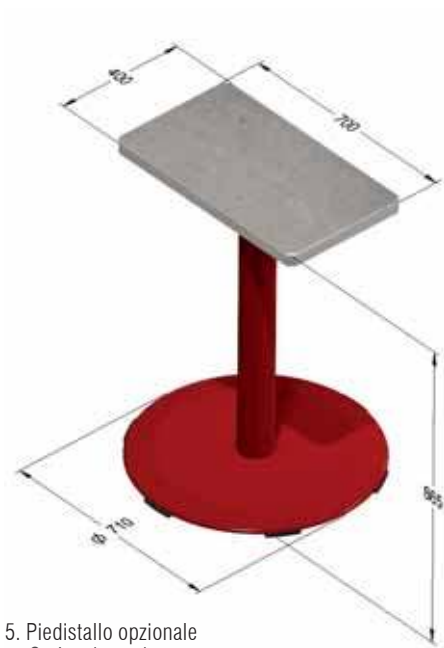

5. Piedistallo opzionale
Optional stand



6. Piano in vetro di serie
Standard glass surface

Opzionali:
Options:



7. Piano bianco white 2141
White 2141 surface



8. Piano sabbia sand. V. 2300
Sand-Coloured V. 2300 surface



9. Piano in marmo di Carrara
White marble surface Carrara



10. Piano starlight white
White starlight surface



SMART

- Basamento in pressofusione con finitura in smalto alimentare.
- Vela, piatto e coprilama in alluminio anodizzato.
- Pressa merce ergonomico in alluminio pressofuso, con denti conformati per bloccare perfettamente il prodotto da tagliare.
- Ampio spazio tra motore e lama per un'agevole pulizia.
- Motore ventilato a servizio continuo.
- Scorrimento carrello su boccole autolubrificanti e perni lappati.
- Affilatoio incorporato con corpo in fusione e doppio smeriglio di serie.
- Dimensioni compatte ma con grande capacità di taglio.
- Versione CE Professionale con sblocco su carro.
- Inclinazione lama 25°.

- *Painted aluminium body.*
- *Anodized aluminium components.*
- *Ergonomic food-presser made of die-cast aluminum with teeth shaped to best block the product to cut.*
- *Wide space between motor and blade for easy cleaning.*
- *Ventilated motor for continuous work.*
- *Carriage running on self-lubricating bushes and lapped pins.*
- *Cast-in body sharpener assembly with 2 standard emery-wheels.*
- *Compact dimensions but great cutting capacity.*
- *Devise for releasing the carriage on CE version.*
- *25° blade inclination.*



1. Ampio spazio tra lama e corpo macchina
More space between blade and body machine



2. Spazioso piano per appoggio prodotto
Large hopper



Optional colors



RS

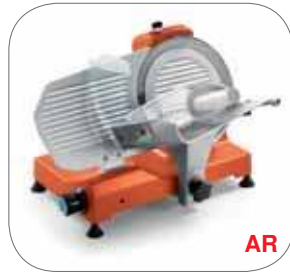

AR



GL



CR



BN



BL



NR

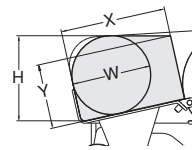
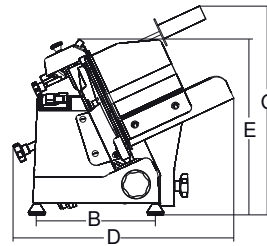
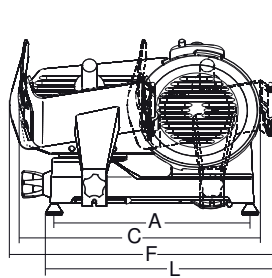

	Ø Lama Ø Blade Ø Messer Ø Lame	Motore Motor Moteur	Spessore taglio Cut thickness Schnittbreite Épaisseur de coupe	Corso carrello Run of carriage Wagenschub Course du chariot	Piatto Hopper Wagen grösse Plateau	A	B	C	D	E	F	G	L	X	Y	H	W	Peso netto Net weight Nettogewicht Poids net	Dimensioni imballo Shipping Verpack. abmessungen Dim.: emballage	Peso lordo Gross weight Bruttogewicht Poids brut
	mm/inch.	watt/Hp	mm	mm	mm	mm	mm	mm	mm	mm	mm	mm	mm	mm	mm	mm	mm	kg	mm	kg
Smart 220	220/9"	132/0,18	13	247	225x240	405	245	480	460	365	555	466	495	220	135	170	160	15	600x500x420	17
Smart 250	250/10"	132/0,18	13	247	225x240	405	245	500	460	365	555	460	480	215	150	185	175	15,5	600x500x420	18

Ø Cuchilla
Ø Lámina
Ø лезвие
刀片直径

Motor
Motor
电动机

Espesor corte
Espesura corte
Толщина нарезки
切削厚度

Desplazamiento del carro
Escorrimiento carrinho
Ход каретки
料斗行程

Piatto
Prato
Лоток
料斗

A

B

C

D

E

F

G

L

X

Y

H

W

Peso netto
Peso líquido
Вес нетто
净重

Dimensiones embalaje
Dimensões embalagem
Пакажны ўпакоўкі
包装尺寸

Peso bruto
Peso bruto
Вес брутто
毛重



TO PAZ

- Fusione in lega di alluminio anodizzato.
- Basamento piatto per una facile pulizia.
- Silenzioso e robusto motore asincrono.
- Trasmissione con robusta cinghia poliV.
- Lama forgiata e temprata a forte spessore.
- Scorrimento carrello su boccole autolubrificanti.
- Affilatoio incorporato in fusione con doppio smeriglio di serie dal modello 220 A.I. in su.
- Disponibili lame teflonate o dentate.
- Inclinazione lama 25°.

- Anodized cast aluminium alloy.
- Flat base for easy cleaning.
- Strong and silent-running asynchronous motor.
- Reliable poliV belt drive.
- Forged, hardened large thickness blades.
- Carriage running on self-lubricating bushes.
- Cast-in sharpener.
- Cast-in sharpener is standard for all models bigger than 220 A.I.
- Teflon coated or toothed blades available
- 25° blade inclination.



TOPAZ 250-275



1.



2.



3.

1. Paramano
Hand guard
2. Protezione inferiore
Underside motor protection plate
3. Affilatoio incorporato 195-220
Without built-in sharpener 195-220

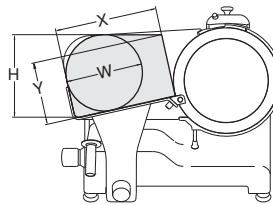
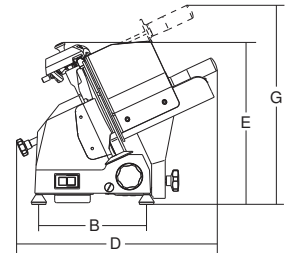
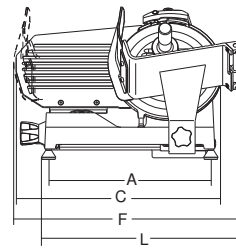

Ø Lama
Ø Blade
Ø Messer
Ø Lame
Motore
Motor
Motor
Motor
Spessore taglio
Cut thickness
Schnittbreite
Epaisseur de coupe
Corso carrello
Run of carriage
Wagenschub
Course du chariot
Piatto
Hopper
Wagen grosse
Plateau

Peso netto
Net weight
Nettogewicht
Poids net
Dimensioni imballo
Shipping
Verpack. abmessungen
Dim. emballage
Peso lordo
Gross weight
Bruttogewicht
Poids brut

	mm/inch.	watt/Hp	mm	mm	mm	mm	mm	mm	mm	mm	mm	mm	mm	mm	mm	mm	kg	mm	kg	
Topaz 195	195/8"	110/0,15	13	162	185x165	310	220	375	355	300	385	360	370	140	110	135	120	10,5	430x400 x370	12
Topaz 220	220/9"	145/0,20	13	245	200x220	380	250	440	410	330	550	400	450	200	130	145	140	13	600x500 x420	15
Topaz 220 A.I.	220/9"	145/0,20	13	245	200x220	380	250	440	410	350	550	400	450	200	140	160	155	13,5	600x500 x420	15,5
Topaz 250 C	250/10"	145/0,20	13	240	230x230	380	250	480	410	360	500	410	475	185	165	180	180	14	600x500 x420	16
Topaz 250	250/10"	145/0,20	13	235	220x225	412	255	480	410	360	515	455	505	210	170	190	180	15,5	600x500 x420	17,5
Topaz 275	275/11"	145/0,20	13	235	220x225	412	255	520	410	370	525	455	505	200	190	205	205	16,5	600x500 x500	19

Ø Cuchilla
Ø Lámina
Ø Messer
Ø 刀片直径
Motor
Motor
Двигатель
电机
Espesura corte
Espesura corte
Толщина реза
切刀厚度
Desplazamiento del carro
Escorrimiento carrito
Ход каретки
料斗行程
Piatto
Piatto
Лоток
料斗

Peso netto
Peso líquido
Вес нетто
净重
Dimensiones embalaje
Dimensions emballage
Размеры упаковки
包装尺寸
Peso bruto
Peso bruto
Вес брутто
毛重



TOPAZ 195 - 220



TOPAZ 220 A.I. - 250

MIRRA



MIRRA 300 Y09

- Fusione in lega di alluminio anodizzato.
- Ampio spazio tra motore e lama per un'agevole pulizia.
- Motore ventilato.
- Lama forgiata e temprata a forte spessore.
- Scorrimento carrello su boccole autolubrificanti e perni lappati.
- Viteria e parafetta in acciaio inox.
- Robusto supporto vela.
- Affilatoio incorporato in fusione con doppio smeriglio di serie.
- Dimensioni compatte ma con grande capacità di taglio.
- Versione CE Professionale con sblocco su carro.
- Disponibili lame teflonate o dentate.
- Inclinazione lama 25°.

- Anodized cast aluminium alloy.
- Great distance between blade and motor for easy cleaning.
- Ventilated motor.
- Forged, hardened large thickness blades.
- Carriage running on self-lubricating bushes and lapped pins.
- Stainless steel screws and slice deflector.
- Strong thickness gauge support.
- Cast-in sharpener assembly.
- Compact dimensions and great cutting capacity.
- CE professional with device for releasing the carriage.
- Teflon coated or toothed blades are available on demand.
- 25° blade inclination.



1.



2.



3.

1. Parafetta tondo rimovibile su mod. 250 opzionale
Removable round slicer deflector on mod. 250 optional
2. Ampio spazio tra lama e corpo macchina
More space between blade and body machine
3. Protezione paracqua su puleggia di serie
Enclosed and sealed belt pulley standard

Ø Lama Ø Blade Ø Messer Ø Lame	Motore Motor Motor	Spessore taglio Cut thickness Schnittbreite Epaisseur de coupe	Corsa carrello Run of carriage Wagenschub Course du charriot	Plato Hopper Wagen grosse Plateau	A	B	C	D	E	F	G	L	X	Y	H	W	Peso netto Net weight Netogewicht Poids net	Dimensioni imballo Shipping Verpack abmessungen Dim. emballage	Peso lordo Gross weight Bruttogewicht Poids brut	
mm/inch.	watt/Hp	mm	mm	mm	mm	mm	mm	mm	mm	mm	mm	mm	mm	mm	mm	mm	kg	mm	kg	
Mirra 220 C	220/9"	147/0,20	13	245	230x240	395	245	480	560	370	570	475	505	220	125	160	160	15	600x500 x420	17
Mirra 250 C	250/10"	147/0,20	13	245	230x240	395	245	500	560	370	570	475	490	220	145	180	170	16	600x500 x420	18
Mirra 275 C	275/11"	147/0,20	13	245	230x240	395	245	535	560	370	570	475	475	215	160	200	190	17	600x500 x420	20
Mirra 300 Y09	300/12"	210/0,29	13	285	250x275	435	295	600	610	420	640	510	535	250	185	225	210	20,5	800x600 x520	23,5

Ø Cuchilla
o Lámina
o лезвие
刀片直径

Motore
Motor
Двигатель
电机

Spessore corte
Espessura corte
Толщина нарезки
切削厚度

Desplazamiento del carro
Escurrimiento carrinho
Ход каретки
料斗行程

Plato
Prato
Лоток
料斗

A

B

C

D

E

F

G

L

X

Y

H

W

Peso netto
Peso líquido
Вес нетто
净重

Dimensiones embalaje
Dimensões embalagem
Размеры упаковки
包装尺寸

Peso bruto
Peso bruto
Вес брутто
毛重



MIRRA 220 C



MIRRA 250 C



MIRRA 275 C



CANOVA



- Linea arrotondata priva di spigoli e viti in vista.
- Perno di scorrimento, cromato rettificato.
- Boccole di scorrimento autolubrificanti.
- Paracolpi su carrello in gomma vulcanizzata.
- Coperchio supporto vela smontabile.
- Parafetta in acciaio inox con incastro a baionetta.
- Tutte le minuterie acciaio inox.
- Sistema di tenuta stagna su puleggia.
- 41 mm di distanza fra la lama e la testa.
- Copertura inferiore.
- Scheda elettronica commutabile 110-220-380 V monofase e trifase.
- Affilatoio con vaschetta inferiore di protezione.
- Estrattore lama di serie versione 300.
- Inclinazione lama 38°.

Canova Top: Manopola alluminio / Piedini in alluminio telescopici con base in gomma / Pulsanti IP 67 in acciaio inox.

Canova: Manopole plastica / Piedini in gomma / Interruttore isolato IP44.

- Rounded design and no sharp edges and visible screws.
- Chrome plated and ground slide rod.
- Self lubricating slide rod bushings.
- Vulcanized rubber stops on carriage.
- Removable support cover for thickness gauge plate.
- Stainless steel slice deflector with bayonet fitting
- Stainless steel screws and fittings.
- Enclosed and sealed belt pulley.
- 41 mm distance between blade and motor.
- Bottom cover.
- Changeover electronic circuit 110-220-380 V single and three phase.
- Built in sharpening tool with bottom protection.
- Standard blade removal tool for 300 ver.
- 38° blade inclination.

Canova Top: Aluminium knob. / Aluminium telescopic feet with rubber base. / Stainless steel pushbuttons with IP67 protection rating.

Canova: Plastic knob. / Rubber feet. / Switch with IP44 protection rating.



CANOVA 300 TOP



1. Ampio spazio tra lama e corpo macchina
Remarkable clearance between blade and machine body.



2. Spazioso piano per appoggio prodotto
Large hopper

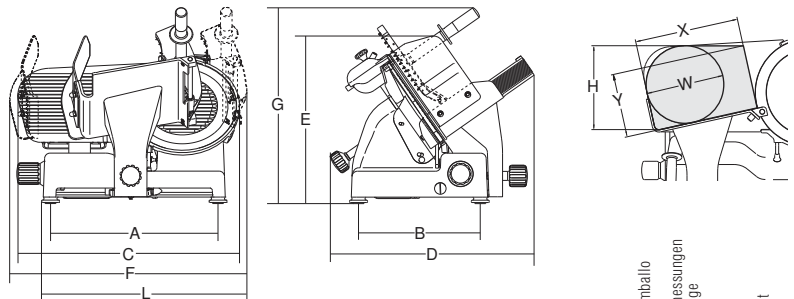

Ø Lama
Ø Blade
Ø Messer
Ø Lame
Motore
Motor
Moteur
Spessore taglio
Cut thickness
Schichtbreite
Epaisseur de coupe
Corsa carrello
Run of carriage
Wagenschub
Course du charriot
Piatto
Hopper
Wagen grösse
Plateau

Peso netto
Net weight
Nettogewicht
Poids net
Dimensioni imballo
Shipping
Verpack abmessungen
Dim. emballage
Peso lordo
Gross weight
Bruttogewicht
Poids brut

	mm/inch.	watt/Hp	mm	mm	mm	mm	mm	mm	mm	mm	mm	mm	mm	mm	mm	mm	mm	kg	mm	kg
Canova 250 / Top	250/10"	147/0,20	19	275	240x230	428	290	560	495	365	660	500	550	230	140	190	175	24,5	800x600x520	27
Canova 275 / Top	275/11"	210/0,29	19	275	240x230	428	290	580	495	360	650	495	530	230	155	208	185	25,5	800x600x520	28
Canova 300 / Top	300/12"	210/0,29	19	275	270x230	428	290	590	495	355	640	495	515	230	175	220	200	26,5	800x600x520	29

Ø Cuchilla
Ø Lámina
Ø лезвiя
刀片直径
Motor
Мотор
电动机
Espesor corte
Espessura corte
Толщина реза
切削厚度
Desplazamiento del carro
Escorrimiento carrinho
Ход каретки
料斗行程
Piatto
Лоток
料斗

Peso netto
Peso líquido
Бес нетто
净重
Dimensiones embalaje
Dimensões embalagem
Размеры упаковки
包装尺寸
Peso bruto
Peso bruto
Бес брутто
毛重



CANOVA 250



CANOVA 250 TOP

CANOVA AUTOMECC



- Caratteristiche affettatrice come Canova 250-275-300.
- Struttura in acciaio inox saldato e arrotondato.
- Trascinamento carrello con sistema meccanico a biella.
- Motore trascinamento ventilato a comando separato con riduttore a bagno d'olio.
- Comandi separati per lama e automatismo.
- Possibilità di sblocco automatismo per un funzionamento manuale.
- 2 sistemi di controllo:
 - Standard on/off,
 - VV: on/off con variatore di velocità.

• The Canova Automecc series offers the same outstanding features of the Canova series adding:

- Stainless steel base
- Piston/rod system carriage motion
- Fan-cooled carriage motion motor with commercial-grade oil bath reduction
- Blade and carriage motion powered by separate controls
- An easily accessible switch arm can convert the unit from automatic to manual operation
- Two control systems:
 - Standard on/off
 - Variable speed available (VV versions).

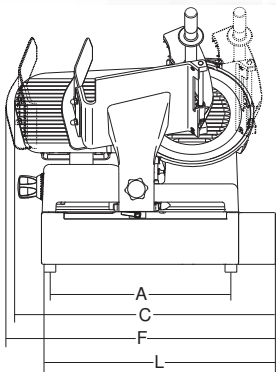

Ø Lama
Ø Blade
Ø Messer
Ø Lame

Motore
Motor
Motor
Moteur

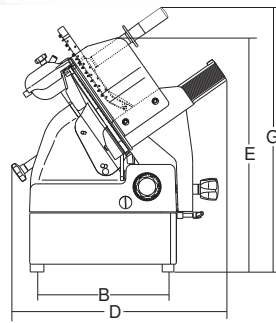

Spessore taglio
Cut thickness
Schnittbreite
Épaisseur de coupe
Corsa carrello
Run of carriage
Wagenschub
Course du chariot
Piatto
Hopper
Wagen grösse
Plateau

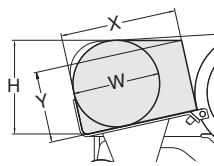

	mm/inch.	watt/HP	mm	mm	mm	mm	mm	mm	mm	mm	mm	mm	mm	mm	mm	mm	mm	kg	mm	kg
Canova 300 Automecc/VV	300/12"	210+180/0,29+0,24	19	275	270x230	428	290	590	495	573	640	650	515	230	175	220	200	42,6	870x840x750	57

Peso netto
Net weight
Nettogewicht
Poids net

Dimensioni imballo
Shipping
Verpack, abmessungen
Dim. emballage

Peso lordo
Gross weight
Bruttogewicht
Poids brut

Ø Cuchilla
Ø Lámina
Ø лезвья
刀片直径

Motor
Motor
电机

Espesor corte
Espesura corte
Толщина нарезки
Desplazamiento del carro
Escorrimiento carricho
Ход каретки
料斗行程

Piatto
Plato
Дорок
料斗

A B C D E F G L X Y H W

Peso netto
Peso líquido
Вес нетто
净重

Dimensiones embalaje
Dimensoes embaaragem
Размеры упаковки
包装尺寸

Peso bruto
Peso bruto
Вес брутто
毛重



1. Leva sollevamento, opzionale
Lifting lever, optional





PALLADIO



PALLADIO 300 TOP

- Linea arrotondata priva di spigoli e viti in vista.
- Perno di scorrimento, cromato rettificato.
- Boccole di scorrimento autolubrificanti.
- Paracolpi su carrello in gomma vulcanizzata.
- Coperchio supporto vela smontabile.
- Parafetta in acciaio inox con incastro a baionetta.
- Tutte le minuterie acciaio inox.
- Sistema di tenuta stagna su puleggia.
- 49,5 mm di distanza fra la lama e la testa.
- Copertura inferiore.
- Scheda elettronica commutabile 110-220-380 V monofase e trifase.
- Affilatoio con vaschetta inferiore di protezione.
- Estrattore lama di serie.
- Inclinazione lama 35°.

PALLADIO TOP

- Manopola alluminio.
- Piedini in alluminio telescopici con base in gomma.
- Pulsanti IP 67 in acciaio inox.
- Fornitura valigetta utensili.

PALLADIO

- Manopole plastica. Piedini in gomma.
- Pulsanti IP 67 in plastica.

PALLADIO INGRANAGGI

- Trasmissione con riduttore ermetico a vite senza fine.
- Lubrificazione a bagno d'olio.
- Non disponibile versione automatica.

- *Rounded design, no sharp edges and visible screws.*
- *Chrome plated and ground slide rod.*
- *Self lubricating slide rod bushings.*
- *Vulcanized rubber stops on carriage.*
- *Removable support cover for thickness gauge plate.*
- *Stainless steel slice deflector with bayonet fitting.*
- *Stainless steel screws and fittings.*
- *Enclosed and sealed belt pulley.*
- *49,5 mm distance between blade and motor.*
- *Bottom cover.*
- *Changeover electronic circuit 110-220-380 V single and three phase.*
- *Built in sharpening tool with bottom protection.*
- *Standard blade removal tool.*
- *35° blade inclination.*

PALLADIO TOP

- *Aluminium knob.*
- *Aluminium telescopic feet with rubber base.*
- *Stainless steel pushbuttons with IP67 protection rating.*
- *Maintenance tool kit.*

PALLADIO

- *Plastic knob. Rubber feet.*
- *Plastic pushbuttons with IP67 protection rating.*

PALLADIO INGRANAGGI

- *Enclosed and sealed worm gear reduction unit.*
- *Oil bath lubrication.*
- *Automatic version not available.*



PALLADIO 330

PALLADIO AUT TOP



1. Ampio spazio tra lama e corpo macchina
More space between blade and body machine



2. Spazioso piano per appoggio prodotto
Large hopper



3. Comandi Palladio AUT
Palladio AUT controls



4. Leva sollevamento, opzionale
Lifting lever, optional

PALLADIO AUT

- Pulsantiera ergonomica con pulsanti IP 67.
- 3 regolazioni della velocità.
- 3 regolazioni della corsa del carrello
- Conteggio delle fette effettuate.
- Impostazione delle fette da tagliare con stop automatico della macchina.
- Motore di trasmissione completamente stagno.
- Trasmissione del moto con cinghia dentata.
- Sistema di sgancio carrello per taglio manuale.
- Produzione fette al minuto: 37 - 70.

Accessori opzionali: Spondina per piatto.

PALLADIO AUT

- Ergomic controls - push buttons with IP67 protection rating.
- 3 speed selection.
- 3 different adjustments for carriage travel.
- Slice counter.
- Slice number setting with automatic stop feature.
- Enclosed and sealed drive motor.
- Positive drive belt.
- Carriage release system for manual slicing.
- Output slices per minute: 37 - 70.

Optional accessories: Side guard for food tray.

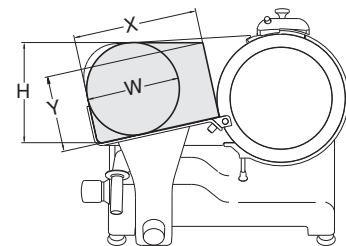
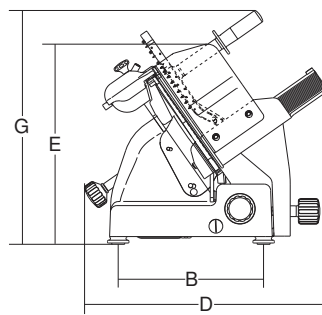
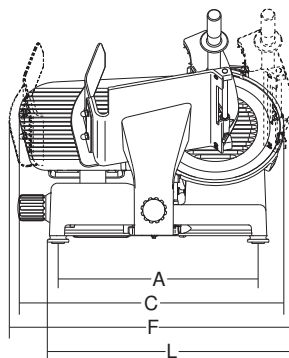

	Ø Lama Ø Blade Ø Messer Ø Lame	Motore Motor Motor Moteur	Spessore taglio Cut thickness Schichtbreite Epaisseur de coupe	Corso carrello Run of carriage Wagenschub Course du chariot	Piatto Hopper Wagen grosse Plateau	A	B	C	D	E	F	G	L	X	Y	H	W	Peso netto Net weight Nettogewicht Poids net	Dimensioni imballo Shipping Verpack. abmessungen Dim. emballage	Peso lordo Gross weight Bruttogewicht Poids brut
	mm/inch.	watt/Hp	mm	mm	mm	mm	mm	mm	mm	mm	mm	mm	mm	mm	mm	mm	mm	kg	mm	kg
Palladio 300 / Top	300/12"	275/0,37	23	310	305x270	465	340	615	547	465	710	545	625	270	190	240	220	35	760x640x700	44
Palladio 330 / Top	330/13"	275/0,37	23	310	305x270	465	340	645	570	455	710	535	590	270	210	260	240	36	760x640x700	45
Palladio 350 / Top	350/14"	370/0,50	23	310	305x270	465	340	660	575	455	710	530	590	270	225	275	250	37	760x640x700	46
Palladio 300 ingr. / Top	300/12"	400/0,54	23	310	305x270	465	340	615	547	465	710	545	625	270	190	240	220	36	760x640x700	45
Palladio 330 ingr. / Top	330/13"	400/0,54	23	310	305x270	465	340	645	570	455	710	535	590	270	210	260	240	37	760x640x700	46
Palladio 350 ingr. / Top	350/14"	400/0,54	23	310	305x270	465	340	660	575	455	710	530	590	270	225	275	250	38	760x640x700	47
Palladio 300 AUT / Top	300/12"	275+200/0,37+0,27	23	310	365x270	465	340	615	660	465	730	650	630	240/270	190	240	220	38	870x840x750	53
Palladio 330 AUT / Top	330/13"	275+200/0,37+0,27	23	310	365x270	465	340	645	660	455	730	650	610	240/270	210	260	240	39	870x840x750	54
Palladio 350 AUT / Top	350/14"	370+200/0,50+0,27	23	310	365x270	465	340	660	660	455	730	650	600	240/270	225	275	250	40	870x840x750	55

Ø Cuchilla
Ø Lamina
Ø лезвие
刀片直径

Motore
Motor
Двигатель
电机

Spessore corte
Espessura corte
Толщина нарезки
切削厚度

Displazamiento del carro
Escorrimiento carrinho
Ход каретки
料斗行程

Piatto
Plato
Лоток
料斗

A

B

C

D

E

F

G

L

X

Y

H

W

Peso netto
Peso líquido
Вес нетто
淨重

Dimensiones embalaje
Dimensões embalagem
Размеры упаковки
包裝尺寸

Peso bruto
Peso bruto
Вес брутто
毛重



PALLADIO AUTO MEC

- Caratteristiche affettatrice come Palladio 300-330-350.
- Struttura in acciaio inox saldato e arrotondato.
- Trascinamento carrello con sistema meccanico a biella.
- Motore trascinamento ventilato a comando separato con riduttore a bagno d'olio.
- Comandi separati per lama e automatismo.
- Possibilità di sblocco automatismo per un funzionamento manuale.
- Piatto Nettuno con sistema di guida prodotto regolabile.
- 2 sistemi di controllo:
 - Standard on/off,
 - VV: on/off con variatore di velocità.
- Produzione fette al minuto:
 - Palladio Automec: 37
 - Palladio Automec VV: 4 - 50

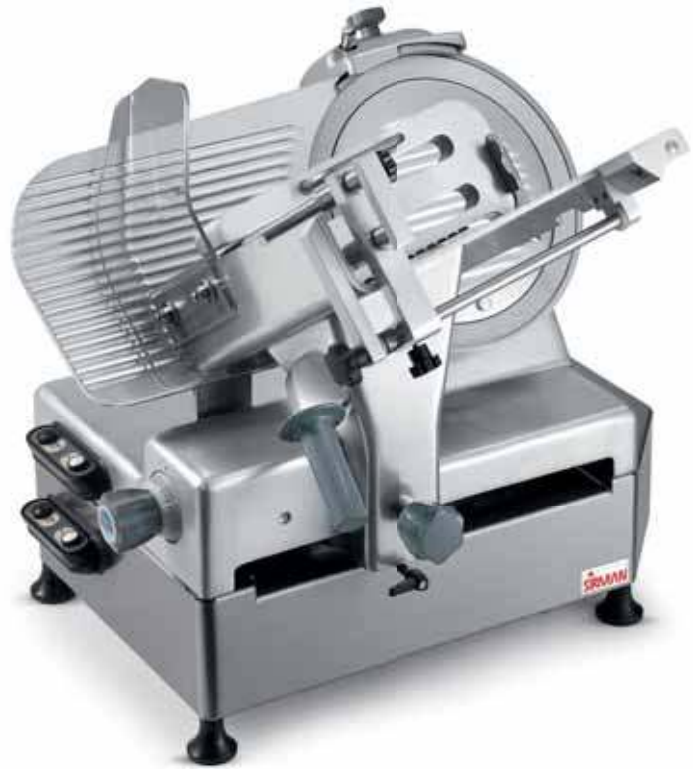

Palladio 350 Automec Frozen: appositamente studiata per il taglio di carni congelate fino a -12°C.

- *The Palladio Automec series offers the same outstanding features of the Palladio series adding:*
- *Stainless steel base*
- *Piston/rod system carriage motion*
- *Fan-cooled carriage motion motor with commercial-grade oil bath reduction*
- *Blade and carriage motion powered by separate controls*
- *An easily accessible switch arm can convert the unit from automatic to manual operation*
- *The exclusive designed carriage "Nettuno" is available with a special end weight and an adjustable vertical product fence to provide stability and advance products evenly.*
- *Two control systems:*
 - *Standard on/off*
 - *Variable speed available (VV versions).*
- *Output slicer per minute:*
 - *Palladio Automec: 37*
 - *Palladio Automec VV: 4 - 50*

Palladio 350 Automec Frozen: especially designed for slicing frozen meat up to -12°C.

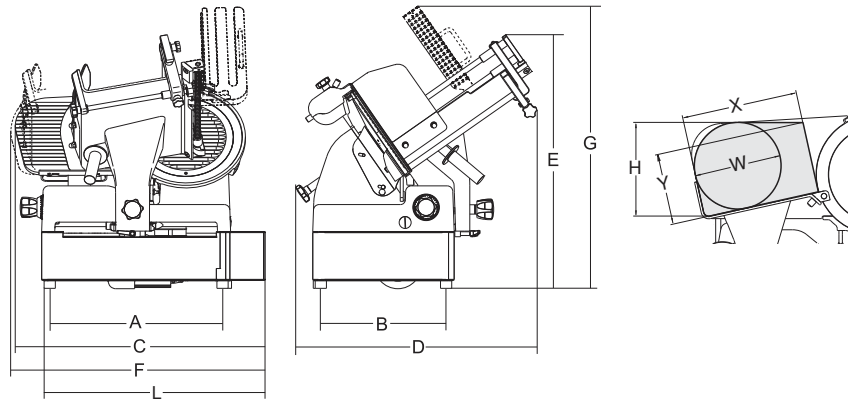

	Ø Lama Ø Blade Ø Messer Ø Lame	Motore Motor Motor Moteur	Spessore taglio Cut thickness Schnittbreite Epaisseur de coupe	Corsa carrello Run of carriage Wagenschub Course du chariot	Piatto Hopper Wagengrösse Plateau	A	B	C	D	E	F	G	L	X	Y	H	W	Peso netto Net weight Nettogewicht Poids net	Dimensioni imballo Shipping Verpack abmessungen Dim. emballage	Peso lordo Gross weight Bruttogewicht Poids brut
	mm/inch.	watt/HP	mm	mm	mm	mm	mm	mm	mm	mm	mm	mm	mm	mm	mm	mm	mm	kg	mm	kg
Palladio 300 Automec/VV	300/12"	275+180/0,37+0,24	23	310	365x270	465	340	667	660	670	685	750	615	240/270	190	240	220	55	870x840x750	70
Palladio 330 Automec/VV	330/13"	275+180/0,37+0,24	23	310	365x270	465	340	684	660	670	700	750	-	240/270	210	260	240	56	870x840x750	71
Palladio 350 Automec/VV	350/14"	370+180/0,50+0,24	23	310	365x270	465	340	685	660	670	700	750	-	240/270	225	275	250	57	870x840x750	72
Palladio 350 Automec Frozen	350/14"	370+180/0,50+0,24	23	310	365x270	465	340	685	660	670	700	750	-	240/270	225	275	250	57	870x840x750	72

Ø Cuchilla
Ø Lámnia
Ø лезвия
Ø 刀片直徑

Motor
Motor
Двигатель
电机

Spessore corte
Espesura corte
Толщина нарезки
切削厚度

Displacemento del carro
Escorrimiento carrinho
Ход каретки
料斗行程

Piatto
Plato
Jarak
料斗

A B C D E F G L X Y H W

Peso netto
Peso líquido
Вес нетто
淨重

Dimensiones embalaje
Dimensões embalagem
Размеры упаковки
包裝尺寸

Peso bruto
Peso bruto
Вес брутто
毛重



YouTube

PALLADIO EVO USA



- Particolare configurazione del basamento e della vela per impedire che sfridi e liquidi vadano nei dispositivi critici della macchina (pulsanti, manopola movimento, ecc.).
- Innovativo sistema di ribaltamento e smontaggio del piatto.
- Puleggia lama senza foro centrale per facilitare la pulizia.
- Movimento vela progressivo, garantisce una maggiore precisione di regolazione taglio delle fette sottili.
- Anello di tenuta sull'albero vela per impedire che i liquidi percolino all'interno della macchina.
- Pulsanti in acciaio inox IP 67 in cassa.

- *Special configuration of the base and slicer table to prevent chips and liquids from entering the critical devices of the machine (buttons, turn knob, etc.).*
- *Hi-tech tipping system and feeding pan disassembly.*
- *New blade pulley without centre hole to facilitate cleaning.*
- *Adjustable slicer table movement, guarantees higher cutting precision of thin slices.*
- *Safety ring on table shaft to prevent liquids from seeping inside the machine.*
- *Blade tilting angle: 35°.*
- *Buttons in insulated stainless steel (IP 67) in housing.*



1.



2.



3.



4.



5.



6.

1. Leva sollevamento, opzionale
Lifting lever, optional
2. Rimozione piatto
Removable hopper
3. Pratico smontaggio del copilama
Easily removable blade cover
4. Mozzo lama chiuso, senza tirante paralama
Blade hub closed, without tie rod cover blade
5. Ampio spazio tra lama e corpo macchina 49 mm
More space between blade and body machine 49 mm
6. Movimento vela progressivo, garantisce una maggiore precisione di regolazione taglio delle fette sottili
Adjustable slicer table movement, guarantees higher cutting precision of thin slices

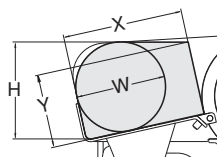
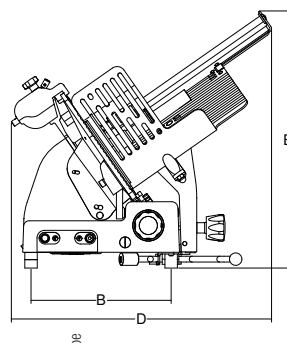
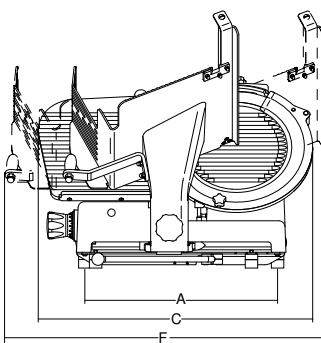

Ø Lama
Ø Blade
Ø Messer
Ø Lame
Motore
Motor
Moteur

Spessore taglio
Cut thickness
Schmittbreite
Épaisseur de coupe

Corsa carrello
Run of carriage
Wagenschub
Course du charriot

Piatto
Hopper
Wagen/grosse
Plateau

A

B

C

D

E

F

X

Y

H

W

Peso netto
Net weight
Nettogewicht
Poids net

Dimensioni imballo
Shipping
Verpack-abmessungen
Dim. emballage

Peso lordo
Gross weight
Bruttogewicht
Poids brut

	mm/inch.	watt/Hp	mm	mm	mm	mm	mm	mm	mm	mm	mm	mm	mm	mm	kg	mm	kg	
Palladio 330 Evo Usa	330/13"	275 / 0,37	23	310	350x290	465	340	660	630	620	730	270	165	260	225	40	870x840x750	55

α Cuchilla
α Lamina
α лезвья
刀片直径

Motor
Moteur

Espresso corte
Espessura corte
Толщина нарезки
切削厚度

Desplazamiento del carro
Escorrimiento carrinho
Ход каретки
料斗行程

A

B

C

D

E

F

X

Y

H

W

Peso netto
Peso líquido
Вес нетто
淨重

Dimensiones embalaje
Dimensões embalagem
Размеры упаковки
包裝尺寸

Peso bruto
Peso bruto
Вес брутто
毛重



RAFFAELLO

- Linea arrotondata priva di spigoli e viti in vista.
- Perno di scorrimento, cromato rettificato.
- Boccole di scorrimento autolubrificanti.
- Paracolpi su carrello in gomma vulcanizzata.
- Coperchio supporto vela smontabile.
- Parafetta in acciaio inox.
- Puleggia lama senza foro centrale per facilitare la pulizia.
- Movimento vela progressivo dei primi 3 mm di apertura, garantisce una maggiore precisione di regolazione taglio delle fette sottili.
- Anello di tenuta sull'albero vela per impedire che i liquidi percolino all'interno della macchina.
- Pratico smontaggio del coprilama
- Tutte le minuterie acciaio inox.
- 49,5 mm di distanza fra la lama e la testa.
- Copertura inferiore.
- Scheda elettronica commutabile 110-220-380 V monofase e trifase.
- Affilatoio con vaschetta inferiore di protezione.
- Estrattore lama di serie.
- Inclinazione lama 35°.

RAFFAELLO TOP

- Manopola alluminio.
- Piedini in alluminio telescopici con base in gomma.
- Pulsanti IP 67 in acciaio inox.
- Fornitura valigetta utensili.

RAFFAELLO

- Manopole plastica.
- Piedini in gomma.
- Pulsanti IP 67 in plastica

- *Rounded design, no sharp edges and visible screws.*
- *Chrome plated and ground slide rod.*
- *Self lubricating slide rod bushings.*
- *Vulcanized rubber stops on carriage.*
- *Removable support cover for thickness gauge plate.*
- *Stainless steel slice deflector.*
- *Blade pulley without centre hole to facilitate cleaning.*
- *Adjustable slicer table movement in the first 3 mm of opening, guarantees higher cutting precision of thin slices.*
- *Safety ring on table shaft to prevent liquids from seeping inside the machine.*
- *Easily removable blade cover*
- *Stainless steel screws and fittings.*
- *Enclosed and sealed belt pulley.*
- *49,5 mm distance between blade and motor.*
- *Bottom cover.*
- *Changeover electronic circuit 110-220-380 V single and three phase.*
- *Built in sharpening tool with bottom protection.*
- *Standard blade removal tool.*
- *35° blade inclination.*



RAFFAELLO 350 TOP



RAFFAELLO 350

RAFFAELLO TOP

- *Aluminium knob.*
- *Aluminium telescopic feet with rubber base.*
- *Stainless steel pushbuttons with IP67 protection rating.*
- *Maintenance tool kit.*

RAFFAELLO

- *Plastic knob.*
- *Rubber feet.*
- *Plastic pushbuttons with IP67 protection rating.*



1. Pratico smontaggio del coprilama
Easily removable blade cover



2. Mozzo lama chiuso, senza tirante paralama
Blade hub closed, without tie rod cover blade



3. Movimento vela progressivo, garantisce una maggiore precisione di regolazione taglio delle fette sottili
Adjustable slicer table movement, guarantees higher cutting precision of thin slices

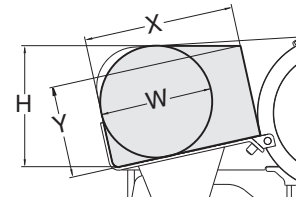
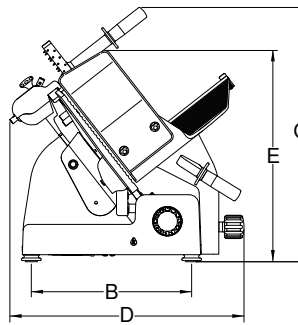
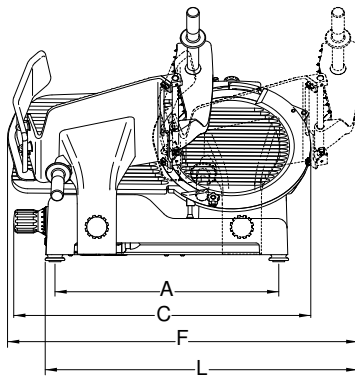

Ø Lama
 Ø Blade
 Ø Messer
 Ø Lame
 Motore
 Motor
 Motor
 Moteur
 Spessore taglio
 Cut thickness
 Schnittbreite
 Epaisseur de coupe
 Corsa carrello
 Run of carriage
 Wagenstich
 Course du charriot
 Piatto
 Hopper
 Wagen
 grosse
 Plateau

Peso netto
 Net weight
 Nettogewicht
 Poids net
 Dimensioni imballo
 Shipping
 Verpaak abmessungen
 Dim. emballage
 Peso lordo
 Gross weight
 Bruttogewicht
 Poids brut

	mm/inch.	watt/HP	mm	mm	mm	A	B	C	D	E	F	G	L	X	Y	H	W	kg	mm	kg
Raffaello 330	330/13"	275/0,37	23	355	330x307	513	340	690	560	475	840	595	725	307	205	260	240	37	760x640x700	46
Raffaello 350	350/14"	370/0,50	23	355	330x307	513	340	715	570	480	840	595	715	307	220	275	250	38	760x640x700	47
Raffaello 370	370/15"	370/0,50	23	355	330x307	513	340	735	580	470	840	590	715	307	230	285	260	39	760x640x700	48

Ø Cuchilla
 Ø Lâmina
 Ø лезвие
 刀片直径
 Motor
 Motor
 电机
 Двигатель
 Espesor corte
 Espessura corte
 Толщина нарезки
 切削厚度
 Desplazamiento del carro
 Escomintamento carrinho
 Ход тележки
 料斗行程
 Piatto
 Plato
 Лоток
 料斗

Peso netto
 Peso líquido
 Вес нетто
 净重
 Dimensiones embalaje
 Dimensões embalagem
 Размеры упаковки
 包装尺寸
 Peso bruto
 Peso bruto
 Вес брутто
 毛重



PALLADIO / GALILEO STONEHENGE

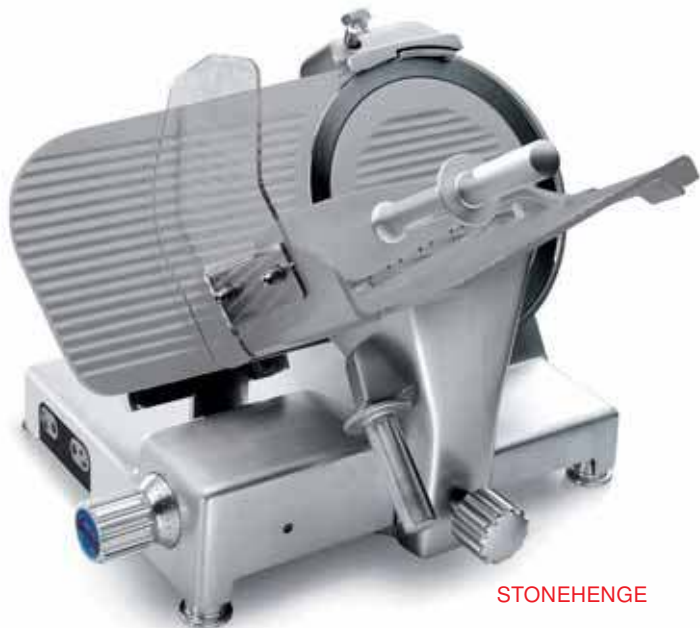

STONEHENGE

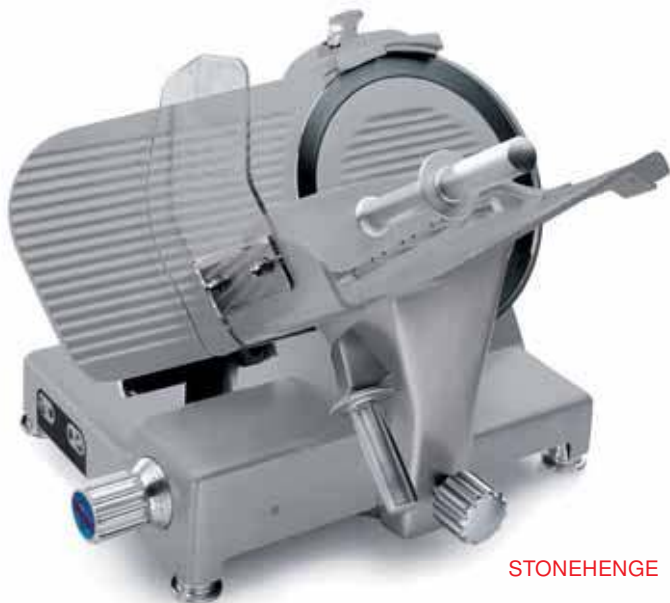

STONEHENGE PLUS

- Trattamento di ceramico-teflonatura superficiale.
- Ideale per la lavorazione di prodotti particolarmente collosi.
- Ottima scorrevolezza superficiale e semplice pulizia.
- Alta resistenza ad acidi e sanificanti.
- Parti rimovibili lavabili in lavastoviglie.
- Disponibile come sovrapprezzo.
- Colore di finitura: grigio alluminio.

Versioni disponibili:

- Stonehenge: vela, paralama, piatto, pressa merce.
- Stonehenge Plus: cassa, vela, supporto vela e coperchio, anello, paralama, piatto, pressa merce, gambo, vaschetta e cappottina affilatoio.

- *Cast aluminum alloy with special ceramic-teflon coating treatment*
- *Ideal for sticky products processing*
- *Excellent product gliding and easy to clean*
- *Highly resistant to acids and sanitizing chemicals*
- *Removable parts are dishwasher safe*
- *Available on demand*
- *Aluminum-gray finish colour .*

Available versions:

- *Stonehenge: thickness plate, blade cover, carriage, end weight, end weight.*
- *Stonehenge Plus: body, thickness plate, thickness plate support and cover, ring, blade cover, carriage, end weight, shank, bottom cover and sharpener cover.*



Le Parti Rimovibili sono lavabili in lavastoviglie!
Removable Parts are dishwasher safe!



YouTube

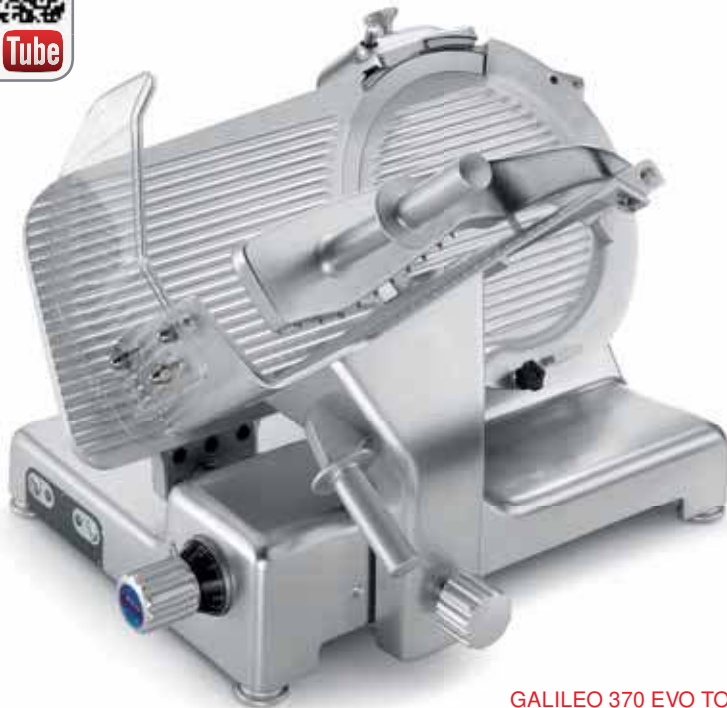

GALILEO 370 EVO TOP

- Rounded design, no sharp edges and visible screws.
- Chrome plated and ground slide rod.
- Self lubricating slide rod bushings.
- Vulcanized rubber stops on carriage.
- Removable support cover for thickness gauge plate.
- Stainless steel slice deflector.
- Stainless steel screws and fittings.
- Blade pulley without centre hole to facilitate cleaning.
- Adjustable slicer table movement in the first 3 mm of opening, guarantees higher cutting precision of thin slices.
- Safety ring on table shaft to prevent liquids from seeping inside the machine.
- Easily removable blade cover
- Bottom cover.
- Changeover electronic circuit 110-220-380 V single and three phase.
- Built in sharpening tool with bottom protection.
- Standard blade removal tool.
- 38° blade inclination.

GALILEO EVO TOP

- Aluminium knob.
- G&B blade.
- Aluminium telescopic feet with rubber base.
- Stainless steel push buttons with IP67 protection rating.
- Maintenance tool kit.

GALILEO EVO

- Plastic knob
- Rubber feet
- Plastic pushbuttons with IP67 protection rating

GALILEO EVO

- Linea arrotondata priva di spigoli e viti in vista.
- Perno di scorrimento, cromato rettificato.
- Boccole di scorrimento autolubrificanti.
- Paracolpi su carrello in gomma vulcanizzata.
- Coperchio supporto vela smontabile.
- Parafetta in acciaio inox.
- Puleggia lama senza foro centrale per facilitare la pulizia.
- Movimento vela progressivo dei primi 3 mm di apertura, garantisce una maggiore precisione di regolazione taglio delle fette sottili.
- Anello di tenuta sull'albero vela per impedire che i liquidi percolino all'interno della macchina.
- Pratico smontaggio del coprilama
- Tutte le minuterie acciaio inox.
- Copertura inferiore.
- Scheda elettronica commutabile 110-220-380 V monofase e trifase.
- Affilatoio con vaschetta inferiore di protezione.
- Estrattore lama di serie.
- Inclinazione lama 38°.

GALILEO EVO TOP

- Manopola alluminio.
- Lama G&B.
- Piedini in alluminio telescopici con base in gomma.
- Pulsanti IP 67 in acciaio inox.
- Fornitura valigetta utensili.

GALILEO EVO

- Manopole plastica.
- Piedini in gomma.
- Pulsanti IP 67 in plastica.



1. Pratico smontaggio del coprilama
Easily removable blade cover



2. Mozzo lama chiuso, senza tirante paralama
Blade hub closed, without tie rod cover blade



GALILEO 350 EVO TOP



3. Design zavorra per piccoli salumi
Fixing arm designed also for small sausages



4. 70 mm di spazio tra lama e corpo macchina
70 mm distance between blade and body machine



5. Galileo Ingranaggi
Lubrificazione a bagno d'olio
Oil bath lubrication



6. Spondina per piatto opzionale
Side guard for food tray optional



7. Tubo verdure opzionale
Optional tube holder for slicing vegetables



8. Leva sollevamento, opzionale
Lifting lever, optional



9. Applicazione bilancia opzionale:
Pesata max Kg 10 - precisione gr. 2
piatto smontabile, formato mm 225x360

Optional application scale:
Shipping weight Kg 10 - Precision gr. 2 remova-
ble tray, dimensions mm 225x360

GALILEO EVO INGRANAGGI

- Trasmissione con riduttore ermetico a vite senza fine.
- Lubrificazione a bagno d'olio.
- Non disponibile versione automatica.

GALILEO EVO INGRANAGGI

- Enclosed and sealed worm gear reduction unit
- Oil bath lubrication
- Automatic model unavailable

GALILEO EVO AUTOMATICA

- Pulsantiera ergonomica con pulsanti IP67.
- 3 regolazioni della velocità,
- 3 regolazioni della corsa del carrello,
- Conteggio delle fette effettuato.
- Impostazione delle fette da tagliare con stop automatico della macchina.
- Motore di trasmissione completamente stagno.
- Trasmissione del moto con cinghia dentata.
- Produzione fette al minuto: 24 - 46

GALILEO EVO AUTOMATICA

- Ergonomic controls - pushbuttons with IP67 protection rating
- 3-speed selection
- 3 different adjustments for carriage travel
- Slice counter
- Slice number setting with automatic stop feature
- Enclosed and sealed drive motor
- Positive drive belt
- Output slices per minute: 24 - 46

Accessori opzionali:

- Spondina per piatto.
- Tubo verdure.

Optional accessories:

- Side guard for food tray
- Tube holder for slicing vegetables



GALILEO 370 EVO INGR. TOP



GALILEO 370 EVO



GALILEO 350 EVO TOP USA



10. Gambe opzionali
Optional legs



GALILEO 350 EVO AUTOMATICA TOP



11. Comandi Galileo AUT
Galileo AUT controls

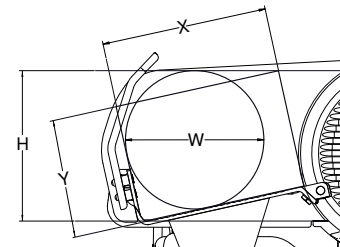
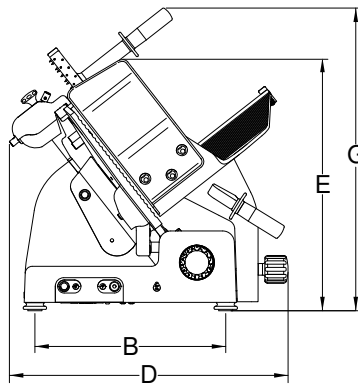
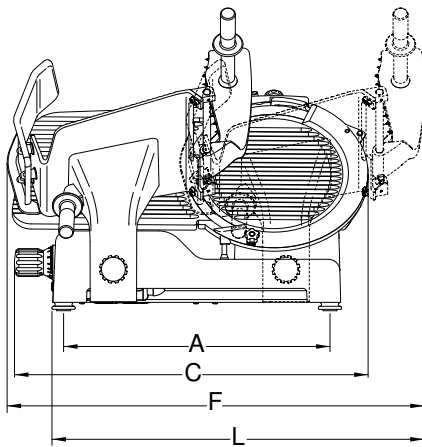

Ø Lama
Ø Blade
Ø Messer
Ø Lame
Motore
Motor
Moteur
Spessore taglio
Cut thickness
Schnittbreite
Epaisseur de coupe
Corso carrello
Run of carriage
Wagenschub
Course du chariot
Piatto
Hopper
Wagen grösse
Plateau

Peso netto
Net weight
Nettogewicht
Poids net
Dimensioni imballo
Shipping
Verpack-abmessungen
Dim. emballage
Peso lordo
Gross weight
Bruttogewicht
Poids brut

	mm/inch.	watt/Hp	mm	mm	mm	mm	mm	mm	mm	mm	mm	mm	mm	mm	mm	mm	mm	mm	kg	mm	kg
Galileo 350 Evo/Top	350/14"	380/0,52	25	365	350x320	515	410	750	590	535	820	700	730	320	210	275	250	56	870x840 x750	72	
Galileo 370 Evo/Top	370/15"	380/0,52	25	365	350x320	515	410	760	600	530	820	700	730	320	230	290	270	57	870x840 x750	73	
Galileo 385 Evo/Top	385/16"	380/0,52	25	365	350x320	515	410	770	605	525	820	700	730	320	240	305	280	58	870x840 x750	74	
Galileo 350 Evo Ingr./Top	350/14"	400/0,54	25	365	350x320	515	410	750	590	535	820	700	730	320	210	275	250	56	870x840 x750	72	
Galileo 370 Evo Ingr./Top	370/15"	400/0,54	25	365	350x320	515	410	760	600	530	820	700	730	320	230	290	270	57	870x840 x750	73	
Galileo 385 Evo Ingr./Top	385/16"	400/0,54	25	365	350x320	515	410	770	605	525	820	700	730	320	240	305	280	58	870x840 x750	74	
Galileo 350 Evo AUT/Top	350/14"	380+400/ 0,52+0,54	25	365	430x320	515	410	750	640	535	820	730	730	285/320	210	275	250	62	870x840 x750	78	
Galileo 370 Evo AUT/Top	370/15"	380+400/ 0,52+0,54	25	365	430x320	515	410	760	650	530	820	730	730	285/320	225	295	266	63	870x840 x750	79	
Galileo 385 Evo AUT/Top	385/16"	380+400/ 0,52+0,54	25	365	430x320	515	410	770	655	525	820	730	730	285/320	230	305	280	64	870x840 x750	80	
Galileo 350 Evo USA/Top	350/14"	380/0,52	25	365	350x312	515	410	730	740	520	810	560	660	280	190	295	250	55	870x840 x750	71	

Ø Cuchilla
Ø Lamina
Ø лезвия
刀片直径
Motor
Motor
Двигатель
电机
Espesor corte
Espessura corte
Толщина нарезки
切削厚度
Desplazamiento del carro
Escorrimiento carrinho
Ход каретки
料斗行程
Piatto
Plato
Лоток
料斗

Peso neto
Peso líquido
Вес нетто
淨重
Dimensiones embalaje
Dimensões embalagem
Размеры упаковки
包裝尺寸
Peso bruto
Peso bruto
Вес брутто
毛重



GALILEO EVO POWER

- Pulsantiera ergonomica con pulsanti IP 67.
- 3 regolazioni della velocità.
- 3 regolazioni della corsa del carrello.
- Movimentazione carro a mezzo di cinghia dentata.
- Affettatrice montata su basamento carrellato in acciaio inox.
- Appositamente pensata per il taglio di carni congelate fino a -10°C.
- Produzione fette al minuto: 24 - 46.

- Ergonomic controls - pushbuttons with IP67 protection rating.
- 3 speed selection.
- 3 different adjustments run for carriage.
- Positive drive belt on carriage.
- Especially designed for slicing frozen meat up to -10°C (14 °F).
- Sturdy stainless steel trestle with casters to provide stability.
- Output slices per minute: 24 - 46.

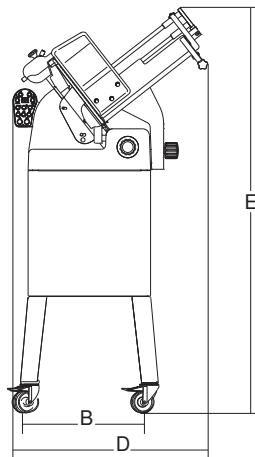
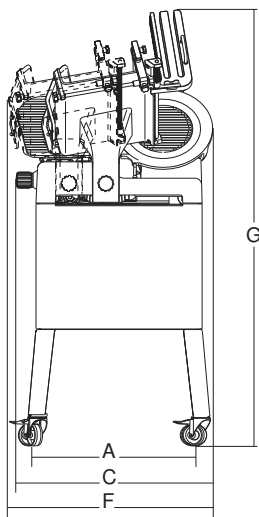
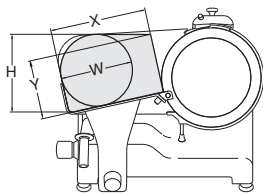

Ø Lama
 Ø Blade
 Ø Messer
 Ø Lame
 Motore
 Motor
 Moteur
 Spessore taglio
 Cut thickness
 Schnittbreite
 Epaisseur de coupe
 Corsa carrello
 Run of carriage
 Wagenschub
 Course du chariot
 Plato
 Hopper
 Wagen grösse
 Plateau

A B C D E F G X Y H W
 Peso netto
 Net weight
 Nettogewicht
 Poids net
 Dimensioni imballo
 Shipping
 Verpack abmessungen
 Dim. emballage
 Peso lordo
 Gross weight
 Bruttogewicht
 Poids brut

	mm/inch.	watt/Hp	mm	mm	mm	mm	mm	mm	mm	mm	mm	mm	mm	mm	mm	kg	mm	kg
Galileo 350 Evo Power TOP	350/14"	400/0,54 1100/1,5	25	365	430x320	610	455	730	732	1510	816	1620	325	210	275	98	870x840 x1650	120

ø Cuchilla
 ø Lâmina
 ø Лезвие
 刀片厚度
 Motor
 Мотор
 Двигатель
 Espesor corte
 Espessura corte
 Толщина нарезки
 Desplazamiento del carro
 Escorrimiento carrinho
 Ход каретки
 料斗行程
 Plato
 Plato
 Лоток
 料斗

Peso netto
 Pésó líquido
 Вес нетто
 净重
 Dimensiones embalaje
 Dimensões embalagem
 Размеры упаковки
 包装尺寸
 Peso bruto
 Pésó bruto
 Вес брутто
 毛重

MIRRA VERTICALE



MIRRA 300 VERT. BS

- Fusione in lega di alluminio anodizzato.
- Ampio spazio tra motore e lama per un'agevole pulizia.
- Motore ventilato.
- Lama forgiata e temprata a forte spessore.
- Perni scorrimento lappati.
- Viteria e parafetta in acciaio inox.
- Robusto supporto vela.
- Affilatoio incorporato in fusione con doppio smeriglio di serie.
- Dimensioni compatte ma con grande capacità di taglio.
- Versione CE Professionale con sblocco su carro.

- Anodized cast aluminium alloy.
- Great distance between blade and motor for easy cleaning.
- Ventilated motor.
- Forged, hardened large thickness blades.
- Lapped sliding pins.
- Stainless steel screws and slice deflector.
- Strong thickness gauge support.
- Cast-in sharpener assembly.
- Compact dimensions but great cutting capacity.
- Device for releasing the carriage.

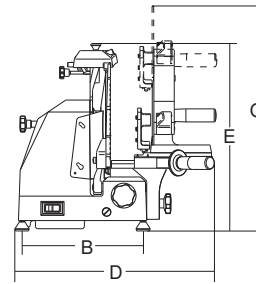
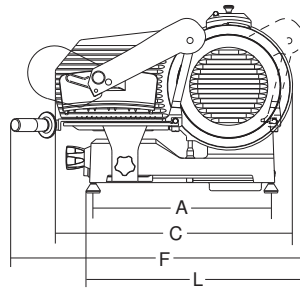
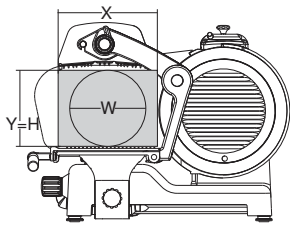

Ø Lama / Ø Blade / Ø Messer / Ø Lame
 Motore / Motor / Motor / Moteur
 Spessore taglio / Cut thickness / Schnittbreite / Epaisseur de coupe
 Corsa carrello / Run of carriage / Wagenschub / Course du charriot
 Piatto / Hopper / Wagen / grosse / Plateau
 A B C D E F G L X Y H W
 Peso netto / Net weight / Nettogewicht / Poids net
 Dimensioni imballo / Shipping / Verpack. abmessungen / Dim. emballage
 Peso lordo / Gross weight / Bruttogewicht / Poids brut

	mm/inch.	watt/Hp	mm	mm	mm	mm	mm	mm	mm	mm	mm	mm	mm	mm	mm	mm	mm	kg	mm	kg
Mirra 220 C Vert.	220/9"	147/0,20	13	225	230x235	400	260	500	535	400	570	405	475	205	150	150	150	16,5	600x500 x500	19
Mirra 250 C Vert.	250/10"	147/0,20	13	230	230x235	400	260	510	535	410	570	410	475	205	170	170	170	17,5	600x500 x500	20
Mirra 275 C Vert.	275/11"	147/0,20	13	220	230x235	400	260	530	535	420	570	425	465	225	205	205	205	18,5	600x500 x500	21
Mirra 250 C Vert. BS	250/10"	147/0,20	13	215	275x260	400	260	510	480	415	700	600	540	270	190	190	190	21,5	600x500 x500	24
Mirra 275 C Vert. BS	275/11"	147/0,20	13	225	275x260	400	260	530	480	420	700	770	540	270	200	200	200	22,5	600x500 x500	25
Mirra 275 Vert. BS	275/11"	210/0,29	13	220	275x260	440	300	580	500	455	740	630	580	255	205	205	205	26	800x600 x520	28,5
Mirra 300 Vert. BS	300/12"	210/0,29	13	265	275x260	440	300	585	540	460	740	770	580	255	215	215	215	27	800x600 x520	29,5

Ø Cuchilla / Ø Lamina / Ø нож / 刀片直径
 Motor / Motor / Двигатель / 电机
 Espesor corte / Espessura corte / Толщина нарезки / 切削厚度
 Desplazamiento del carro / Escorrimiento carritino / Ход вагончика / 料斗行程
 Plato / Plato / Лоток / 料斗
 A B C D E F G L X Y H W
 Peso neto / Peso líquido / Вес нетто / 净重
 Dimensiones embalaje / Dimensiones embalagen / Размеры упаковки / 包装尺寸
 Peso bruto / Peso bruto / Вес брутто / 毛重



MIRRA 250 C VERT.



MIRRA 250-275 C VERT. BS



MIRRA 275 C VERT.



GIOTTO



- Linea arrotondata priva di spigoli e facile da pulire.
- Perno di scorrimento, cromato rettificato e lappato.
- Boccole di scorrimento autolubrificante.
- Paracolpo su carrello in gomma vulcanizzata.
- Coperchio supporto vela smontabile.
- Parafetta rimovibile in acciaio inox con incastro rapido a baionetta.
- Tutte le minuterie acciaio inox.
- Copertura inferiore con coperchio per accesso diretto ai componenti elettrici.
- Scheda elettromeccanica commutabile 110-220V monofase e 380V trifase.
- Affilatoio con vaschetta inferiore di protezione.
- Sistema di tenuta stagna su puleggia.
- 41 mm di distanza fra la lama e il corpo macchina.

GIOTTO

- Manopole in plastica.
- Piedini in gomma.
- Interruttore isolato IP 44

GIOTTO TOP

- Manopole in alluminio.
- Piedini in alluminio telescopici con base in gomma.
- Pulsanti IP 67 in acciaio inox

GIOTTO BS

- Braccio stringi salumi con staffa in acciaio inox.

GIOTTO VCO

- Particolarmente richieste nei mercati nordici.
- Piatto a vasca per tagliare ogni tipo di prodotto.
- Staffa blocca prodotto in alluminio smontabile con chiodi in acciaio e denti fresati sul lato lama.



GIOTTO 300 BS TOP

- Innovative rounded design and no sharp edges or visible screws.
- Chrome plated ground and lapped slide rod.
- Self lubricating slide rod bushings.
- Vulcanised rubber stops on carriage.
- Removable support cover for thickness gauge plate.
- Stainless steel slice deflector with snap-on bayonet fitting.
- Stainless steel screws and fittings.
- Bottom cover for accessing electrical components.
- Changeover electronic circuit 110-220V single and 380V three-phase
- Built-in sharpening tool with bottom protection
- Enclosed and sealed belt pulley
- 41 mm distance between blade and motor

GIOTTO

- Plastic knobs.
- Rubber feet.
- Switch with IP44 protection rating.

GIOTTO TOP

- Aluminium knobs.
- Aluminium telescopic feet with rubber base.
- S/Steel pushbuttons with IP67 protection rating.

GIOTTO BS

- Easy to remove stainless steel meat grip arm.

GIOTTO VCO

- Specially required by the Northern European marketplace.
- Product table designed to slice all types of products.
- Removable aluminum end weight.
- Designed with grooves: nails underneath.



GIOTTO 300 VCO TOP



GIOTTO 300 BS



1. Zavorra smontabile BS
Removable food pusher BS



2. Ampio spazio tra lama e corpo macchina
More space between blade and body machine



3. Spazioso piano per appoggio prodotto
Large hopper

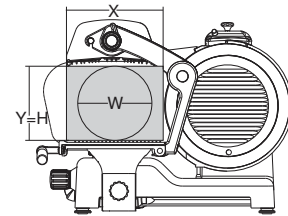
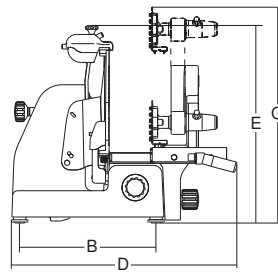
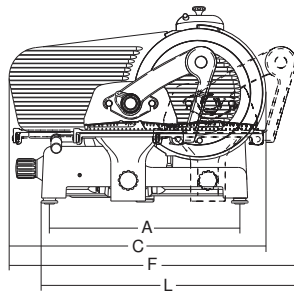

	Ø Lama Ø Blade Ø Messer Ø Lame	Motor Motor Moteur	Spessore taglio Cut thickness Schnittbreite Épaisseur de coupe	Corona carrello Wagenschub Course du chariot	Piatto Hopper Wagen Plateau	A	B	C	D	E	F	G	L	X	Y	H	W	Peso netto Net weight Nettogewicht Poids net	Dimensioni imballo Shipping Verpack, abmessungen Dim. emballage	Peso lordo Gross weight Bruttogewicht Poids brut
	mm/inch.	watt/Hp	mm	mm	mm	mm	mm	mm	mm	mm	mm	mm	mm	mm	mm	mm	mm	kg	mm	kg
GIOTTO 250 BS / Top	250/10"	210/0,29	30	275	275x260	425	320	550	540	435	790	550	620	255	190	190	190	27	800x600x520	30
GIOTTO 275 BS / Top	275/11"	210/0,29	30	275	275x260	425	320	560	540	450	790	560	620	255	205	205	205	28	800x600x520	31
GIOTTO 300 BS / Top	300/12"	210/0,29	30	275	275x260	425	320	580	540	460	790	570	620	255	220	220	220	29	800x600x520	32
GIOTTO 250 VCO / Top	250/10"	210/0,29	30	275	250x240	425	320	550	590	435	640	475	540	240	190	190	190	26	800x600x520	29
GIOTTO 275 VCO / Top	275/11"	210/0,29	30	275	250x240	425	320	560	590	450	640	485	540	240	205	205	205	27	800x600x520	30
GIOTTO 300 VCO / Top	300/12"	210/0,29	30	275	250x240	425	320	580	590	460	640	495	540	240	220	220	220	28	800x600x520	31

Ø Cuchilla
Ø Lámina
Ø лезвия
刀片直径

Motor
Двигатель
电机

Esponsor corte
Espesura corte
Толщина нарезки
切削厚度

Desplazamiento del carro
Escorrimiento carrinho
Ход каретки
料斗行程

Piatto
Лоток
料斗

A B C D E F G L X Y H W

Peso netto
Peso líquido
Вес нетто
净重

Dimensiones embalaje
Dimensões embalagem
Размер упаковки
包装尺寸

Peso bruto
Peso brutto
Вес брутто
毛重





MANTEGNA



- Linea arrotondata priva di spigoli e facile da pulire.
- Perno di scorrimento, cromato rettificato e lappato.
- Boccole di scorrimento autolubrificante.
- Paracolpo su carrello in gomma vulcanizzata.
- Coperchio supporto vela smontabile.
- Parafetta rimovibile in acciaio inox con incastro rapido a baionetta.
- Tutte le minuterie acciaio inox.
- Copertura inferiore con accesso diretto ai componenti elettrici.
- Scheda elettromeccanica commutabile 110-220-380 V monofase e trifase.
- Affilatoio con vaschetta inferiore di protezione.
- Sistema di tenuta stagna su puleggia.
- 48 mm di distanza fra la lama e il corpo macchina.
- Estrattore lama di serie.

MANTEGNA TOP

- Manopole alluminio.
- Piedini in alluminio telescopici con base in gomma.
- Pulsanti IP 67 in acciaio inox.
- Kit manutenzione e sanificazione in pratica valigetta.

MANTEGNA

- Manopole in plastica.
- Piedini in gomma.
- Pulsanti IP 67 in plastica

MANTEGNA BS

- Braccio stringisalumi con staffa chiodata inox rimovibile per la pulizia.

MANTEGNA VCO

- Particolarmente richieste nei mercati nordici.
- Piatto a vasca per tagliare ogni tipo di prodotto.
- Staffa blocca prodotto in alluminio smontabile.
- Staffa con chiodi in acciaio e denti fresati sul lato lama.
- Disponibile anche nella versione con braccetto mobile.



MANTEGNA 300 BS TOP

- Innovative rounded design and no sharp edges or visible screws.
- Chrome plated ground and lapped slide rod.
- Self lubricating slide rod bushings.
- Vulcanised rubber stops on carriage.
- Removable support cover for thickness gauge plate.
- Stainless steel slice deflector with snap-on bayonet fitting.
- Stainless steel screws and fittings.
- Bottom cover for accessing electrical components.
- Changeover electronic circuit 110-220-380 V single and three-phase
- Built-in sharpening tool with bottom protection
- Enclosed and sealed belt pulley
- 48 mm distance between blade and motor
- Standard blade removal tool

MANTEGNA

- Plastic knobs.
- Rubber feet.
- Plastic pushbuttons with IP67 protection rating.

MANTEGNA BS

- Easy to remove stainless steel meat grip arm.

MANTEGNA VCO

- Specially required by the Northern European marketplace.
- Product table designed to slice all types of products.
- Removable aluminum end weight.
- Designed with grooves: nails underneath.
- Available with double articulating arm on end weight.

MANTEGNA TOP

- Aluminium knobs.
- Aluminium telescopic feet with rubber base.
- S/steel pushbuttons with IP67 protection rating.
- Maintenance tool kit.



MANTEGNA 300 BS



MANTEGNA 300 VCS

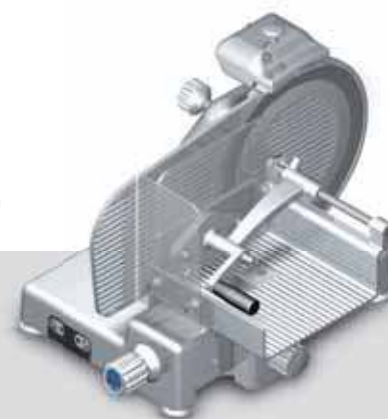

MANTEGNA 300 VCO BM TOP



1. Zavorra smontabile BS
Removable food pusher BS

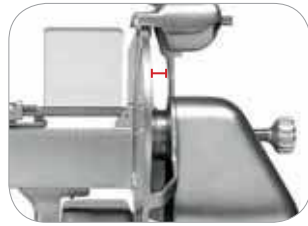

2. Ampio spazio tra lama e corpo macchina
More space between blade and body machine



3. Zavorra smontabile VCS
Removable food pusher VCS



4. Comandi per le versioni Top, di serie
Standard controls for Top versions

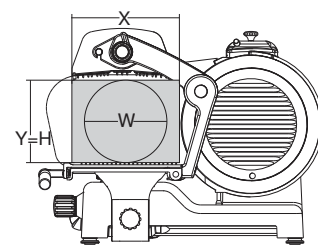
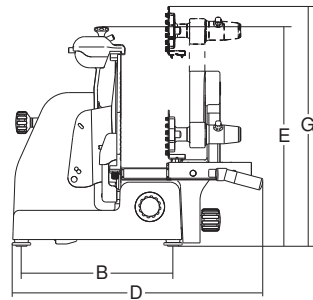
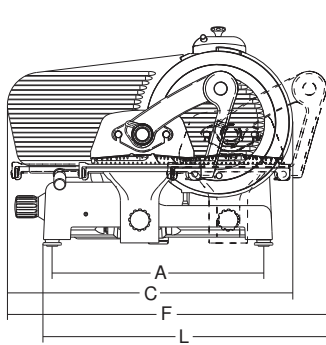

Ø Lama
Ø Blade
Ø Messer
Ø Lame
Moteur
Motor
Moteur
Spessore taglio
Cut thickness
Schnittbreite
Epaisseur de coupe
Corso carrello
Hopper
Wagen
Wagenschub
Course du chariot

Piatto
Hopper
Wagen
Wagenschub
Plateau

Peso netto
Net weight
Nettogewicht
Poids net
Dimensioni imballo
Shipping
Verpack. abmessungen
Dim. emballage
Peso lordo
Gross weight
Bruttogewicht
Poids brut

	mm/inch.	watt/Hp	mm	mm	mm	mm	mm	mm	mm	mm	mm	mm	mm	mm	mm	mm	mm	kg	mm	kg
Mantegna 300 BS/Top	300/12"	275/0,37	29	310	300x270	468	338	635	600	500	750	695	650	270	230	230	230	36,5	870x840x750	51,5
Mantegna 330 BS/Top	330/13"	275/0,37	29	310	300x270	468	338	645	600	515	750	705	630	270	245	245	245	37	870x840x750	52
Mantegna 350 BS/Top	350/14"	370/0,50	29	310	300x270	468	338	660	600	530	750	715	630	270	255	255	255	38	870x840x750	53
Mantegna 300 VCS/Top	300/12"	275/0,37	29	310	340x250	468	338	635	685	500	720	560	610	250	225	225	225	36	870x840x750	52
Mantegna 330 VCS/Top	330/13"	275/0,37	29	310	340x250	468	338	645	685	515	720	560	580	250	235	235	235	37	870x840x750	53
Mantegna 350 VCS/Top	350/14"	370/0,50	29	310	340x250	468	338	660	685	530	720	560	580	250	245	245	245	38	870x840x750	54
Mantegna 300 VCO/Top	300/12"	275/0,37	29	310	280x260	468	338	635	652	500	677	520	610	260	230	230	230	35	870x840x750	50
Mantegna 330 VCO/Top	330/13"	275/0,37	29	310	280x260	468	338	645	652	515	677	520	585	260	245	245	245	36	870x840x750	51
Mantegna 350 VCO/Top	350/14"	370/0,50	29	310	280x260	468	338	660	652	530	677	520	585	260	255	255	255	37	870x840x750	52
Mantegna 300 VCO BM/Top	300/12"	275/0,37	29	310	280x260	468	338	635	585	500	677	660	610	260	230	230	230	36	870x840x750	51
Mantegna 330 VCO BM/Top	330/13"	275/0,37	29	310	280x260	468	338	645	585	515	677	660	585	260	245	245	245	37	870x840x750	52
Mantegna 350 VCO BM/Top	350/14"	370/0,50	29	310	280x260	468	338	660	585	530	677	660	585	260	255	255	255	38	870x840x750	53

Ø Cuchilla
Ø Lamina
Ø нож
刀片直径
Мотор
Motor
Двигатель
电机
Espesor corte
Espessura corte
Толщина нарезки
切割厚度
Desplazamiento del carro
Escorrimiento carrinho
Ход каретки
料斗行程

Piatto
Plato
Лоток
料斗

Peso netto
Peso líquido
Вес нетто
净重
Dimensiones embalaje
Dimensões embalagem
Размеры упаковки
包装尺寸
Peso bruto
Peso bruto
Вес брутто
毛重



MANTEGNA 300 VCO TOP



MANTEGNA 300 VCS TOP



TIZIANO



- Linea arrotondata priva di spigoli e facile da pulire.
- Perno di scorrimento, cromato rettificato e lappato.
- Boccole di scorrimento autolubrificante.
- Paracolpo su carrello in gomma vulcanizzata.
- Coperchio supporto vela smontabile.
- Parafetta rimovibile in acciaio inox con incastro rapido a baionetta.
- Tutte le minuterie acciaio inox.
- Scheda elettromeccanica commutabile 110-220-380 V monofase e trifase.
- Affilatoio con vaschetta inferiore di protezione.
- Sistema di tenuta stagna su puleggia.
- 48 mm di distanza fra la lama e il corpo macchina.
- Estrattore lama di serie.

TIZIANO TOP

- Manopole alluminio
- Piedini in alluminio telescopici con base in gomma.
- Pulsanti IP 67 in acciaio inox
- Kit manutenzione e sanificazione in pratica valigetta.

TIZIANO

- Manopole in plastica.
- Piedini in gomma.
- Pulsanti IP 67 in plastica

TIZIANO BS

- Braccio stringisalumi con staffa chiodata inox rimovibile per la pulizia.



TIZIANO 350 BS TOP

- Innovative rounded design and no sharp edges or visible screws.
- Chrome plated ground and lapped slide rod.
- Self lubricating slide rod bushings.
- Vulcanised rubber stops on carriage.
- Removable support cover for thickness gauge plate.
- Stainless steel slice deflector with snap-on bayonet fitting.
- Stainless steel screws and fittings.
- Changeover electronic circuit 110-220-380 V single and three-phase.
- Built-in sharpening tool with bottom protection.
- Enclosed and sealed belt pulley.
- 48 mm distance between blade and motor.
- Standard blade removal tool.

TIZIANO TOP

- Aluminium knobs
- Aluminium telescopic feet with rubber base
- Stainless steel pushbuttons with IP67 protection rating
- Maintenance tool kit

TIZIANO

- Plastic knobs
- Rubber feet
- Plastic pushbuttons with IP67 protection rating.

TIZIANO BS

- Easy to remove stainless steel meat grip arm.



TIZIANO VCS TOP



TIZIANO VCS



TIZIANO BS



1. Zavorra smontabile BS
Removable food pusher BS

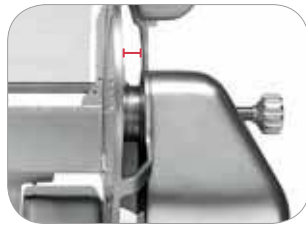

2. Ampio spazio tra lama e corpo macchina
More space between blade and body machine



3. Zavorra smontabile VCS
Removable food pusher VCS



4. Comandi per le versioni Top, di serie
Standard controls for Top versions

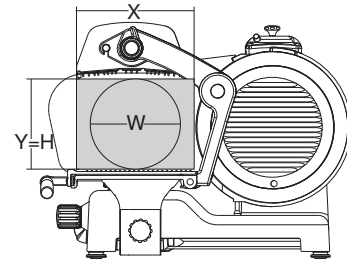
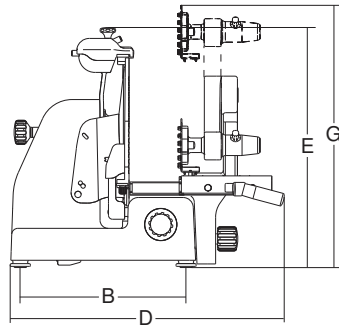
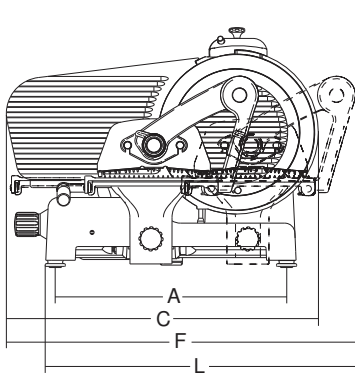

	Ø Lama Ø Blade Ø Messer Ø Lame	Motore Motor Motor Moteur	Spessore taglio Cut thickness Schnittbreite Epaisseur de coupe	Corso carrello Run on carriage Wagenschub Course du charriot	Piatto Hopper Wagen grosse Plateau	A	B	C	D	E	F	G	L	X	Y	H	W	Peso netto Net weight Nettogewicht Poids net	Dimensioni imballo Shipping Verpack. abmessungen Dim. emballage	Peso lordo Gross weight Brutogewicht Poids brut
	mm/inch.	watt/Hp	mm	mm	mm	mm	mm	mm	mm	mm	mm	mm	mm	mm	mm	mm	mm	kg	mm	kg
Tiziano 350 BS/Top	350/14"	380/0,52	29	355	305x295	513	338	738	590	535	805	720	705	305	255	255	255	41,5	870x840 x830	57,5
Tiziano 370 BS/Top	370/15"	380/0,52	29	355	305x295	513	338	760	590	545	805	730	705	305	270	270	270	42,5	870x840 x830	58,5
Tiziano 350 VCS/Top	350/14"	380/0,52	29	355	350x287	513	338	745	672	535	795	565	650	287	245	245	245	42	870x840 x830	58
Tiziano 370 VCS/Top	370/15"	380/0,52	29	355	350x287	513	338	765	672	545	795	575	650	287	260	260	260	43	870x840 x830	59

Ø Cuchilla
Ø Lamina
Ø Лезвие
刀片直径

Motor
Motor
电动机

Espesor corte
Espessura corte
Толщина нарезки
切削厚度

Desplazamiento del carro
Escorrimiento carrinho
Ход каретки
料斗行程

Piatto
Piatto
Лоток
料斗

A

B

C

D

E

F

G

L

X

Y

H

W

Peso netto
Peso líquido
Вес нетто
净重

Dimensiones embalaje
Dimensões embalagem
Размеры упаковки
包装尺寸

Peso bruto
Peso bruto
Вес брутто
毛重



LEONARDO EVO



LEONARDO 370 EVO BS2 TOP

- Linea arrotondata priva di spigoli e viti in vista.
- Affettatrice collocabile su un piano di lavoro da 70 cm.
- Lama a costa bassa per minimizzare l'attrito con il prodotto
- Perno di scorrimento, cromato rettificato e lappato.
- Ottimo scorrimento del carro grazie alle boccole in ghisa lappate.
- Carrello ammortizzato con paracolpi in gomma vulcanizzata.
- Parafetta in acciaio inox
- Sistema di tenuta stagna su puleggia.
- Puleggia lama senza foro centrale per prevenire infiltrazioni e facilitare la pulizia.
- Movimento vela progressivo dei primi 3 mm di apertura, garantisce una maggiore precisione di regolazione taglio delle fette sottili.
- Pratico smontaggio del coprilama
- Tutte le minuterie in acciaio inox.
- Affilatoio con vaschetta inferiore di protezione.
- Paragrasso in acciaio inox facilmente smontabile.
- Altezza di lavoro agevolata per aiutare l'operatore
- 70 mm di distanza fra la lama e la testa.
- Estrattore lama di serie.

LEONARDO EVO TOP

- Manopole alluminio.
- Lama G&B costa bassa.
- Piedini in alluminio telescopici con base in gomma.
- Pulsanti IP 67 in acciaio inox.
- Valigetta con utensili manutenzione e CD dimostrativo.

- *Rounded design and no sharp edges or visible screws.*
- *Size can fit 70 cm deep table*
- *Low profile reduced friction blade*
- *Chrome plated ground and lapped slide rod.*
- *Smooth sliding thanks to lapped iron bushings*
- *Lapped cast iron slide rod bushing.*
- *Vulcanised rubber stops on carriage.*
- *Stainless steel slice deflector.*
- *Hermetic pulley*
- *Blade pulley without centre hole to facilitate cleaning.*
- *Adjustable slicer table movement in the first 3 mm of opening, guarantees higher cutting precision of thin slices.*
- *Easily removable blade cover*
- *Stainless steel screws and fittings.*
- *Built-in sharpening tool with bottom protection.*
- *Easy to remove grease guard.*
- *Standard blade removal tool.*
- *70 mm distance between blade and motor.*

LEONARDO EVO TOP

- *Aluminium knobs.*
- *G&B blade.*
- *Aluminium telescopic feet with rubber base.*
- *Stainless steel pushbuttons with IP67 protection rating.*
- *Maintenance tool kit and demo CD.*



LEONARDO 350 EVO BS



LEONARDO 350 EVO VCS



1. Zavorra smontabile Leonardo BS
Removable food pusher BS



2. Zavorra smontabile Leonardo BS2
Removable food pusher BS2



3. Zavorra smontabile Leonardo BS3
Removable food pusher BS3



4. Zavorra smontabile Leonardo VCS
Removable food pusher VCS

LEONARDO EVO

- Manopole plastica.
- Piedini in gomma.
- Pulsanti IP 67 in plastica.

LEONARDO EVO BS

- Braccio blocca salume con staffa in acciaio inox facilmente smontabile.

LEONARDO EVO BS2

- Braccio con apertura agevolata e manopola ergonomica.
- Sistema integrato che all'apertura allontana automaticamente la staffa dalla lama.
- Staffa di grandi dimensioni in acciaio inox facilmente smontabile.
- Piatto e scorrevoli perfettamente paralleli, con rialzo per sostegno prodotto.

LEONARDO EVO BS3

- Braccio stagno anche per lavaggio con acqua (escluso lavastoviglie, idropulitrice, immersione).
- Manopola ergonomica ed apertura agevolata.
- Sistema integrato che all'apertura allontana automaticamente la staffa dalla lama.
- Staffa basculante per adattarsi a qualsiasi prodotto.
- Staffa smontabile di grandi dimensioni in acciaio inox.

LEONARDO EVO

- Plastic knob.
- Rubber feet.
- Plastic pushbuttons with IP67 protection rating.

LEONARDO EVO BS

- Easy to remove stainless steel meat grip arm.

LEONARDO EVO BS2

- Easy to raise arm with ergonomic handgrip.
- While opening it automatically backs off the blade.
- Amply dimensioned stainless arm easy to remove.
- Tray and slides perfectly parallel, and with raised plate for improved food grip.

LEONARDO EVO BS3

- Water-resistant, double-sealed articulating arm (except dishwasher, pressure washer, immersion).
- Easy to open and adjust thanks to the ergonomic handle.
- While opening it automatically backs off the blade.
- Toggling and removable stainless steel end weight to hold products firmly in place.



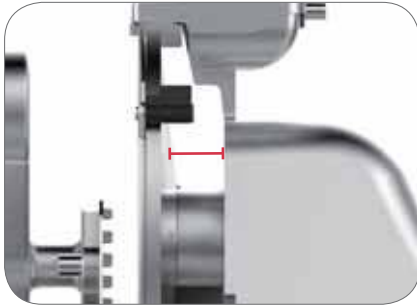

5. Ampio spazio tra lama e corpo macchina
More space between blade and body machine



6. Massima vicinanza alla lama
Distance to blade



7. Comandi per le versioni Top, di serie
Standard controls for Top versions



8. Di serie su versioni Top / Standard for Top versions
Piedini in alluminio telescopici con base in gomma
Aluminium telescopic feet with rubber base



9. Movimento vela progressivo, garantisce una maggiore precisione di regolazione taglio delle fette sottili
Adjustable slicer table movement, guarantees higher cutting precision of thin slices



10. Parafetta in acciaio
Slice guard in steel



11. Paracolpo carrello
Hopper's buffer



12. Affilatoio incorporato
Incorporated sharpener



13. Protezione inferiore
Underside motor protection plate

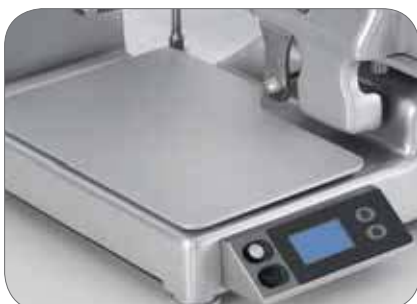

14. Applicazione bilancia opzionale:
Pesata max Kg 10 - precisione gr. 2
piatto smontabile, formato mm 225x360

Optional application scale:
*Shipping weight Kg 10 - Precision gr. 2
removable tray, dimensions mm 225x360*



15. Maschera per estrazione lama
Guard for blade extraction



16. Valigetta con kit di manutenzione di serie su versioni Top
Small suitcase with the maintenance kit Standard for Top versions

LEONARDO EVO BS

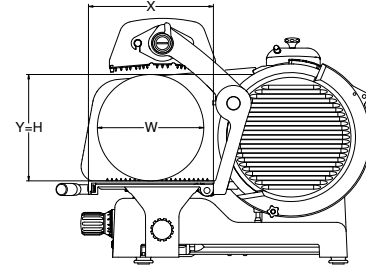
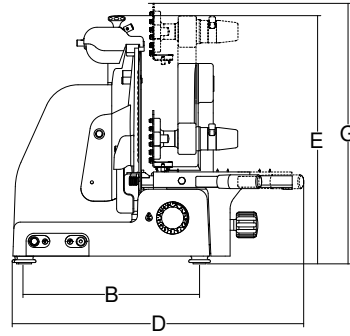
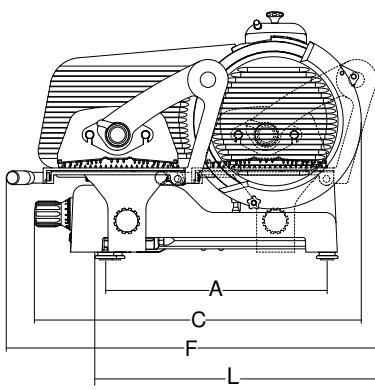

LEONARDO EVO VCS

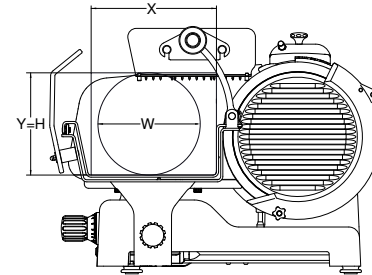
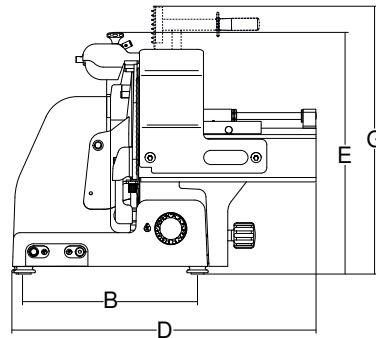
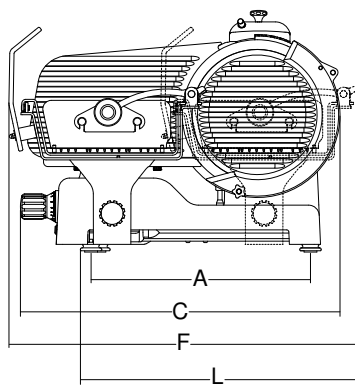

	Ø Lama Ø Blade Ø Messer Ø Lame	Motore Motor Moteur	Spessore taglio Cut thickness Schnittbreite Epaisseur de coupe	Corso carrello Run of carriage Wagenschub Course du chariot	Platto Hopper Wagen gresse Plateau	A	B	C	D	E	F	G	L	X	Y	H	W	Peso netto Net weight Nettogewicht Poids net	Dimensioni imballo Shipping Verpack, ammassungen Dm. emballage	Peso lordo Gross weight Bruttogewicht Poids brut
	mm/inch.	watt/Hp	mm	mm	mm	mm	mm	mm	mm	mm	mm	mm	mm	mm	mm	mm	mm	kg	mm	kg
Leonardo 350 EVO BS	350/14"	380/0,52	25	370	350x320	515	410	733	676	570	876	633	710	330	250	250	250	56	870x840 x830	72
Leonardo 370 EVO BS	370/15"	380/0,52	25	370	350x320	515	410	750	676	580	876	624	710	330	270	270	270	58	870x840 x830	74
Leonardo 385 EVO BS	385/16"	380/0,52	25	370	350x320	515	410	766	676	600	876	624	745	330	280	280	280	59	870x840 x830	75
Leonardo 350 EVO VCS	350/14"	380/0,52	25	370	430x300	515	410	750	742	570	830	595	665	295	240	240	240	60	870x840 x830	76
Leonardo 370 EVO VCS	370/15"	380/0,52	25	370	430x300	515	410	760	742	580	830	586	665	295	258	258	258	61	870x840 x830	77
Leonardo 385 EVO VCS	385/16"	380/0,52	25	370	430x300	515	410	770	742	600	830	606	665	295	272	272	272	62	870x840 x830	78
Leonardo 350 EVO BS2 Top	350/14"	380/0,52	25	370	350x320	515	410	750	676	567	887	635	682	330	250	250	250	59	870x840 x830	75
Leonardo 370 EVO BS2 Top	370/15"	380/0,52	25	370	350x320	515	410	760	676	577	887	626	682	330	270	270	270	60	870x840 x830	76
Leonardo 385 EVO BS2 Top	385/16"	380/0,52	25	370	350x320	515	410	767	676	597	887	626	682	330	280	280	280	61	870x840 x830	77
Leonardo 350 EVO VCS Top	350/14"	380/0,52	25	370	430x300	515	410	750	742	570	830	595	665	295	240	240	240	61	870x840 x830	77
Leonardo 370 EVO VCS Top	370/15"	380/0,52	25	370	430x300	515	410	760	742	580	830	586	665	295	258	258	258	62	870x840 x830	78
Leonardo 385 EVO VCS Top	385/16"	380/0,52	25	370	430x300	515	410	770	742	600	830	600	665	295	272	272	272	63	870x840 x830	79

Ø Cuchilla
Ø Lamina
Ø лезвья
刀片直径

Motor
Motor
Двигатель

Espressor corte
Espesura core
Толщина нарезки
切削厚度

Desplazamiento del carro
Escorrimiento carrinho
Ход каретки
料斗行程

Plato
Prato
Лоток
料斗

A

B

C

D

E

F

G

L

X

Y

H

W

Peso neto
Peso líquido
Вес нетто
净重

Dimensiones embalaje
Dimensões embalagem
Размеры упаковки
包装尺寸

Peso bruto
Peso bruto
Вес брутто
毛重

RISTORAZIONE | FOOD PROCESSORS

Ideata nei minimi dettagli per risolvere tutte le problematiche legate alla gestione della cucina professionale, la linea di macchine per la ristorazione progettate e prodotte da Sirman vanta una grande varietà di proposte che vanno dal tagliaverdure al pelapatate, dalle grattuge al cutter multiuso e a molti altri strumenti estremamente preziosi per garantire un risultato di qualità.

Contraddistinti da un disegno originale ed elegante, tali strumenti assicurano tutti la massima funzionalità ed igiene grazie alla scelta di selezionati materiali di costruzione e al pieno rispetto delle più severe norme di sicurezza alimentare.

Developed with care over even the tiniest detail to deal with all the problems encountered in running a professional kitchen, this range of catering appliances designed and manufactured by Sirman can boast a great variety of options that range from the vegetable-parer to the potato-peeler, from the grater to the all-purpose food-cutter and many other extremely precious tools for ensuring good-quality results.

Distinguished by an original and elegant design, these tools all guarantee the utmost in practicality and hygiene thanks to the choice of carefully-selected materials for their manufacture and compliance with the most severe standards concerning the safety of foodstuffs.





SINFONIA - CONCERTO

macchine per la pasta fresca pasta machines

- Adatta alle esigenze del piccolo e medio ristorante.
- Pratica, veloce ed estremamente facile da pulire e sanificare.
- Costruzione in acciaio inox AISI 304.
- Potente motore ventilato con riduzione ad ingranaggi a bagno d'olio.
- Performante pala impastatrice facilmente rimovibile.
- Coperchio in acciaio inox interbloccato.
- Pratica e rimovibile tramoggia per versare la parte liquida in modo ottimale.
- Coclea, bocca e ghiera in acciaio inox.
- Ampia disponibilità di trafilè in bronzo.
- Motorino tagliapasta con variatore opzionale.

Sinfonia 2

- Vasca in alluminio anodizzato
- Comandi IP 54
- Sistema di ventilazione forzata anche a motore spento.

Concerto 5

- Comandi in acciaio inox IP 67.
- Sistema di ventilazione forzata temporizzata anche a motore spento.



SINFONIA 2

CONCERTO 5
con tagliapasta opzionale
optional pasta cutter

- Designed for medium-duty operations, ideal for small to medium-size restaurants.
- Reliable, user-friendly and easy to clean.
- Stainless steel AISI 304 construction.
- Powerful, air-cooled motor with oil bath gear box reducer.
- High-performance and easy to remove kneading paddle.
- Interlocked stainless steel lid.
- Convenient removable funnel to add liquid ingredients during processing.
- Stainless steel worm, head and ring.
- Full availability of any kind of dies.
- Variable-speed pasta cutter available.



1. Tagliapasta opzionale
Optional pasta cutter



2. Impasto
Dough

Sinfonia 2

- Bowl made of anodized aluminium
- IP 54 controls
- Forced air-cooling system for heavy-duty use.

Concerto 5

- IP 67 stainless steel kneading and extruding controls.
- Forced air-cooling system for heavy-duty use.

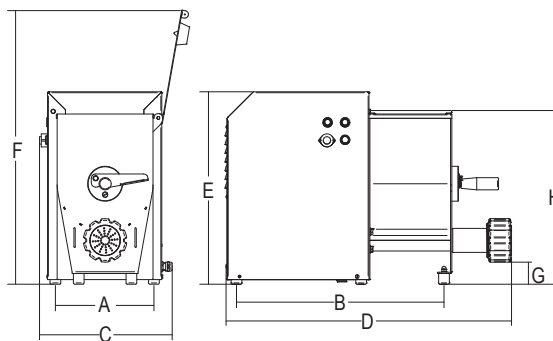

	Potenza Power Spannung Puissance	Alimentazione Power source Betriebsspannung Alimentation	Capacità vasca Bowl capacity Behälter Kapazität Capacité cuve	Capacità impasto Dough capacity Teig Kapazität Capacité pâte	Produzione/h. Output/h. Leistung/h. Débit/h.	Trafilè Dies Matrize Filtres	A	B	C	D	E	F	G	H	Peso netto Net weight Nettogewicht Poids net	Dimensioni imballo Shipping Verpack, abmessungen Dim. emballage	Peso lordo Gross weight Bruttogewicht Poids brut
	watt/HP	lt	kg	kg/h.	ø mm	mm	mm	mm	mm	mm	mm	mm	mm	mm	kg	mm	kg
Sinfonia 2	370/0,5	230V/50Hz	6	2,5	5	59	206	411	263	577	407	489	65	353	28	750x580x800	37
Concerto 5	750/1	230V/50Hz	10	4	8	75	226	476	305	665	442	630	50	391	42	760x640x770	50

Potencia
Potência
Мощность

Alimentación
Alimentação
Электропитание

Capacidad tina
Capacidade recipiente
Объем емкости

Capacidad masa
Capacidade la massa de pão
Тесто порции/часовая

Producción/h.
Produção/h.
Производительность

Trafiladoras
Moíde
Формы

A

B

C

D

E

F

G

H

Peso netto
Peso líquido
Вес нетто

Dimensiones embalaje
Dimensões embalagem
Размеры упаковки

Peso bruto
Peso bruto
Вес брутто

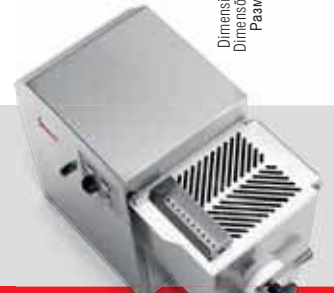

CONCERTO 5



YouTube



SIRPASTA PLUS Y15

SIRPASTA Y15

macchine per la pasta fresca
pasta machines



- Impasto facile e veloce con il sistema spirale planetaria.
- Capienza vasca 20 Lt per un impasto da 4 Kg (3 Kg farina).
- Vasca e spirale facilmente smontabili per pulizia e sanificazione.
- Coclea inox e corpo trafilina in bronzo al nickel.
- Trafilina in bronzo con ampia disponibilità di formati.
- Motorino tagliapasta a velocità variabile standard per SIRpasta Plus, opzionale per SIRpasta.

Alla SIRpasta Plus si possono successivamente applicare:

- Sfogliatrice Automatica PIACENZA con rulli da 120 mm.

A questa si possono aggiungere:

- 5 diversi cassettei per tagliatelle da 2-5-6-8-10 mm.
- Accessorio Raviolatrice BOLOGNA a sfoglia singola.
- Potenza motore HP 0,75 230V.



SIRPASTA Y15

- Planetary spiral mixer for easy and fast dough mixing.
- Bowl capacity 20 Lt for 4 Kg dough (3 Kg flour).
- Bowl and spiral easily removable for cleaning and sanitizing.
- Stainless steel worm and nickel bronze extruder head.
- Bronze die with large availability of pasta shapes.
- Pasta cutter with variable speed (standard on SIRpasta Plus, optional on SIRpasta).

Optional accessories (SIRpasta Plus only):

- Automatic Sheeter PIACENZA with 120 mm rollers.

More accessories can be then connected to the Sheeter:

- 5 size Tagliatelle maker, 2-5-6-8-10 mm.
- Ravioli maker BOLOGNA working on a single pasta sheet.
- Motor power HP 0,75 230V.



SIRPASTA PLUS Y15



SIRPASTA Y15



PIACENZA



BOLOGNA



SIRPASTA Y15 + BOLOGNA EL

Accessorio Sfogliatrice PIACENZA

- Da applicarsi solamente all'impastatrice SIRpasta Plus
- Cassetti per tagliatelle
- Peso accessorio: 10 Kg

Accessorio Raviolatrice BOLOGNA

- La Raviolatrice BOLOGNA è applicabile solo sulla sfogliatrice PIACENZA, quindi sulla SIRpasta Plus o sulla macchina indipendente Sfogliatrice COMO
- Peso accessorio: 15 Kg
- Produzione oraria: 22-33 ravioli/minuto

Pasta Sheeter PIACENZA

- To be used with SIRpasta Plus only
- Tagliatelle maker
- Net weight: 10 Kg

Ravioli Maker BOLOGNA

- Ravioli maker BOLOGNA can be attached on the Sheeter PIACENZA only, then on the SIRpasta Plus or on the independent Sheeter COMO
- Net weight: 15 Kg
- Output: 22-33 ravioli/minute



1. Cassetto per tagliatelle
Tagliatelle maker



SIRPASTA PLUS Y15 + PIACENZA

SIRPASTA PLUS Y15 + PIACENZA

SIRPASTA PLUS Y15+ PIACENZA+ BOLOGNA

TRAFILE / DIES



SIRPASTA Y15

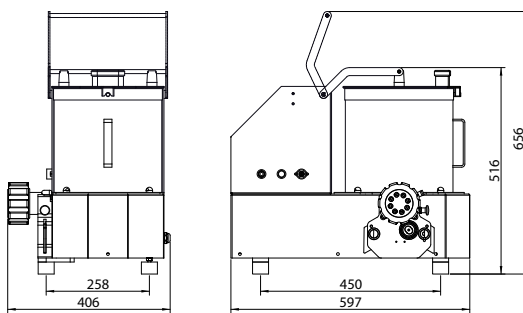

SIRPASTA PLUS Y15

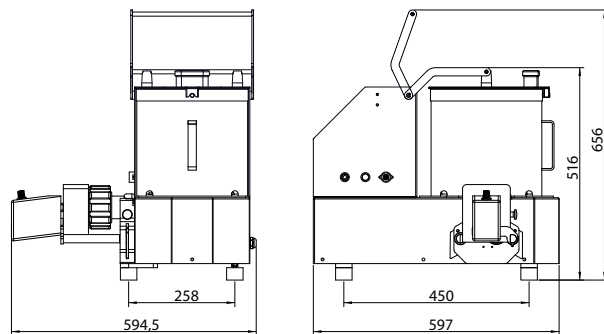

SIRPASTA PLUS Y15 + PIACENZA

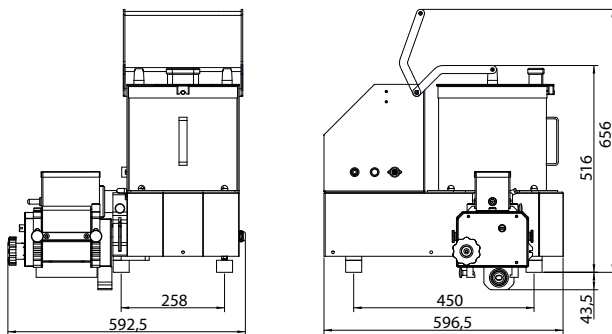

SIRPASTA PLUS Y15 + PIACENZA + BOLOGNA

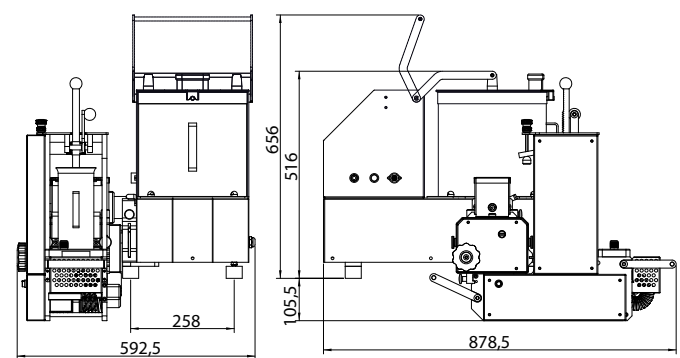

	Potenza Power Spannung Puissance	Alimentazione Power source Betriebsspannung Alimentation	Capacità vasca Bowl capacity Beken Kapazität Capacité cuve	Capacità impasto Dough capacity Teig Kapazität Capacité pâte	Produzione/h. Output/h. Leistung/h. Débit/h.	Produzione/h.estrusore Extruder output/h. Extruderleistung/h. Débit/h. extrudeur	Trafile Dies Matrize Filières	Peso netto Net weight Nettogewicht Poids net	Dimensioni imballo Shipping Verpack abmessungen Dim. emballage	Peso lordo Gross weight Bruttogewicht Poids brut
	watt/Hp		lt	kg	kg/h.	kg/h.	ø mm	kg	mm	kg
Sirpasta Y15	550/0,75	230V/50Hz	20	4	8/9	16	75	52	840x840x850	67
Sirpasta Plus Y15	550/0,75	230V/50Hz	20	4	8/9	16	75	52	840x840x850	67
	Potencia Potência Мощность 功率	Alimentación Alimentação Электроснабжение 电源	Capacidad tina Capacidade recipiente Объем бункера 容量 容器	Capacidad masa Capacidade la massa de pão Тесто потенциала 面团容量	Produção/h. Produção/h. 产量/小时	Produção/h. extrusora Produção/h. extrusora 挤出机产量/小时	Trafiladoras Moide Финеры 模头	Peso neto Peso líquido Бес-Нето 净重	Dimensiones embalaje Dimensões embalagem Размеры упаковки 包装尺寸	Peso bruto Peso bruto Бес-Брутто 毛重



SIRPASTA MAXI

macchina per la pasta fresca

pasta machine

Macchina a spirale a movimento planetario per effettuare l'impasto di pasta fresca e pane.

Macchina fornita su mobile con ruote e pratiche guide per posizionare le cassette alimentari cm 60x40x5 con il prodotto lavorato o gli accessori.

- capacità vasca lt 52.
- 14 Kg di impasto finito (10 Kg farina)
- Coclea e vasca inox, spirale in alluminio, corpo trafila in bronzo
- Vasca, spirale, coclea e bocca di trafilazione facilmente smontabili per pulizia e sanificazione
- Trafila in bronzo con ampia disponibilità di formati
- Coltello taglia pasta motorizzato con regolazione della velocità per il taglio della pasta lunga o corta di serie.
- Accessorio applicabile: Raviolatrice Bologna EL.

Spiral planetary motion machine for making fresh pasta and bread.

The machine comes on a stand with wheels and a practical guide for positioning the food trays cm 60x40x5 with the finished product or accessories.

- bowl capacity lt 52.
- 14 kg of finished dough (10 kg flour)
- Auger and stainless steel tray, aluminium spiral, die plate in bronze.
- Tray, spiral, auger and die outlet are easily removable for cleaning and sanitizing.
- Bronze die plate with many formats available.
- Standard equipment includes motorized pasta cutter with speed adjustment for cutting long or short pasta.
- Accessory: Bologna EL ravioli maker.



1. Impasto
Dough



SIRPASTA MAXI - pasta corta/ short

SIRPASTA MAXI - pasta lunga/ long

SIRPASTA MAXI - ravioli



	Potenza Power Spannung Puissance	Alimentazione Power source Betriebsspannung Alimentation	Capacità vasca Bowl capacity Becken Kapazität Capacité cuve	Capacità impasto Dough capacity Teig Kapazität Capacité pâte	Trafile Dies Mâtrize Filières	Dimensioni max Overall dimensions Abmessungen max Dimensions max	Peso netto Net weight Nettogewicht Poids net	Dimensioni imballo Shipping Verpack. abmessungen Dim. emballage	Peso lordo Gross weight Bruttogewicht Poids brut
	watt/HP		lt	kg	ø mm	mm	kg	mm	kg
Sirpasta Maxi	1100/1,5	230V/50Hz	52	14	109	800x1080 h.1515	202,5	-	-
	Potencia Potência Мощность 功率	Alimentación Alimentação Электропитание 电源	Capacidad línea Capacidade recipiente Объем бункера 容器容量	Capacidad masa Capacidade la massa de pão Тесто порция 面团容量	Trafiadoras Molde Фильеры 模具	Dimensiones máx Dimensões máx Макс. Габарит 整机尺寸	Peso neto Peso líquido Вес нетто 净重	Dimensiones embalaje Dimensões embalagem Размеры упаковки 包装尺寸	Peso bruto Peso bruto Вес брутто 毛重



SIRPASTA MAXI + tagliapasta/pasta cutter

SIRPASTA MAXI + sfoglia regolabile

SIRPASTA MAXI + BOLOGNA EL



COMO

sfgliatrice automatica automatic sheeter

- Macchina sfogliatrice che sfrutta il principio delle gramole tipico delle soluzioni industriali, per produrre la sfoglia in una sola passata.
- Struttura in acciaio inox.
- Motore da 0,37 Kw, 4 poli.
- Peso netto kg 15.
- Gruppo sfoglia in alluminio, rulli in acciaio.
- Ampia tramoggia di carico della pasta.
- Motore potente e ventilato.
- Regolazione dello spessore della sfoglia.
- Larghezza sfoglia mm 120.
- Sfgliatrice apribile per una facile e rapida pulizia.
- Cassetto per tagliatelle opzionale da mm 2-5-6-8-10.
- Possibilità di applicare la raviolatrice Bologna.

- *Sheeter machine that works according to the principle of olive oil machines typical of industrial solutions, to produce the dough in a single run.*
- *Structure in stainless steel.*
- *0.37 kW 4 pole motor.*
- *Net weight: 15 Kg.*
- *Sheet unit in aluminium, steel rollers.*
- *Spacious hopper to feed the dough.*
- *Powerful and ventilated motor.*
- *Adjustable dough thickness.*
- *Sheet width mm 120.*
- *The kneading machine can be opened for easy and quick cleaning.*
- *Optional tray for tagliatelle noodles: size mm 2-5-6-8-10.*
- *Option to assemble with Bologna ravioli machine.*

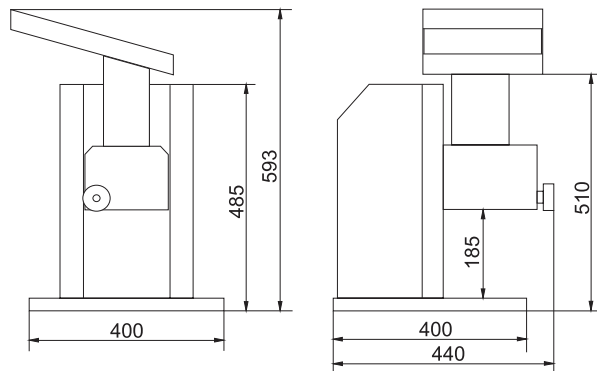



YouTube



SANSONE 42
Taglierina opzionale
Optional pasta cutter

SANSONE

tirasfoglia pasta roller



- Potente tirasfoglia realizzata in 4 misure.
- Realizzazione verticale che riduce l'ingombro sul tavolo da lavoro e agevola la presa della sfoglia in uscita.
- Costruzione in acciaio inox.
- Motore ventilato a servizio continuo con doppia riduzione.
- Riduttore coassiale + trasmissione a catena.
- Regolazione spessore pasta 0÷10 mm.
- Protezione zona carico con micro di sicurezza.
- Ampio scivolo di carico sfoglia.
- Applicazione taglierina opzionale in tre misure, mm 2 - 6 - 12.
- Larghezza taglierina mm 165.
- Ideale anche per laminare la pizza.



SANSONE 52

SANSONE 42
Taglierina opzionale
Optional pasta cutter

SANSONE 32

- Powerful dough roller available in 4 sizes.
- Vertical construction that reduces the space taken up on the working counter and facilitates gripping of the dough at outfeed.
- Built out of stainless steel.
- Ventilated motor in non-stop operating mode with dual reduction.
- Coaxial reduction gear+ belt transmission.
- Adjustable dough thickness 0÷10 mm.
- Infeed area protected with safety microswitch.
- Wide chute for dough infeed.
- Application of optional cutter available in three sizes, mm 2 - 6 - 12.
- Width pasta cutter mm 165.
- Perfect also to laminate pizza.



1. Protezione mani
Hand protection

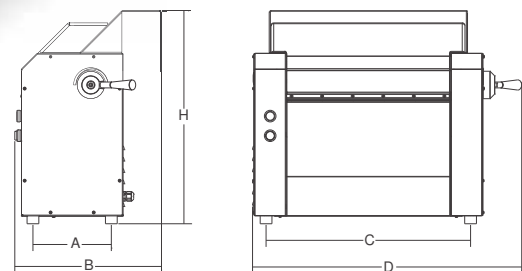

	Potenza Power Spannung Puissance	Alimentazione Power source Betriebsspannung Alimentation	Dimensioni rullo Roller dimensions Wälze gröÙe Dimensions rouleau	A	B	C	D	H	Peso netto Net weight Nettogewicht Poids net	Dimensioni imballo Shipping Verpack. abmessungen Dim. emballage	Peso lordo Gross weight Bruttogewicht Poids brut
	watt/HP		mm	mm	mm	mm	mm	mm	kg	mm	kg
Sansone 25	370/0,5	230-400V/50Hz	∅ 60x250	200	375	352	515	545	30	760x640x800	43
Sansone 32	370/0,5	230-400V/50Hz	∅ 60x320	200	375	422	600	545	52	760x640x800	65
Sansone 42	370/0,5	230-400V/50Hz	∅ 60x420	200	375	522	700	545	59	760x640x800	72
Sansone 52	370/0,5	230-400V/50Hz	∅ 60x520	200	375	622	800	545	66	760x640x800	79
	Potencia Potência Мощность 功率	Alimentación Alimentação Электроснабжение 電源	Dimensiones rodillo Dimensões rolos Размеры ролика 滚筒尺寸	A	B	C	D	H	Peso netto Peso líquido Вес нетто 淨重	Dimensiones embalaje Dimensões embalagem Размеры упаковки 包裝尺寸	Peso bruto Peso bruto Вес брутто 毛重



TM2

tagliaverdure vegetable cutters



- Realizzazione in lega di alluminio e acciaio inox.
- Motore ventilato per uso continuo.
- Design estremamente compatto per una migliore gestione degli spazi in cucina.
- L'esclusivo sistema a caduta diretta del prodotto permette di lavorare anche prodotti morbidi e delicati come mozzarella e altri formaggi.
- Sicurezza garantita da 3 microinterruttori: su leva, coperchio e vasca.
- Vasca raccogliette con interblocco in dotazione.
- Disponibile con coperchio inox lavabile in lavastoviglie.
- Ampia disponibilità di dischi per tutte le applicazioni.

- Aluminium alloy and S/S construction.
- Ventilated motor for continuous operation.
- Thanks to its compact design the machine is easy to install inside every kitchen.
- The exclusive feeding system makes easy to process also soft products like mozzarella cheese.
- Safe operation is ensured by interlock switches on product pusher, lid and collecting tray.
- Version with dishwashing safe S/S lid available.
- Large number of discs available for every purpose.



TM2 Inox
Coperchio inox
Stainless steel hopper lid

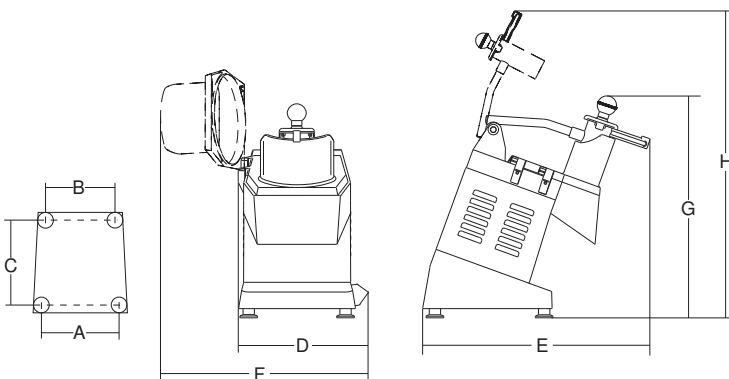

	Potenza Power Spannung Puisseance	Alimentazione Power source Betriebsspannung Alimentation	Giri disco Disc revolutions Kreislauf Tours Disques	A	B	C	D	E	F	G	H	Peso netto Net weight Nettogewicht Poids net	Dimensioni imballo Shipping Verpack. abmessungen Dim. emballage	Peso lordo Gross weight Bruttogewicht Poids brut
	watt/HP		r.p.m.	mm	mm	mm	mm	mm	mm	mm	mm	kg	mm	kg
TM2 Inox	515 /0,7	230-400V/50Hz	300	225	195	255	280	510	-	510	770	17,5	720x350x500	21
TM2 All.	515 /0,7	230-400V/50Hz	300	225	195	255	280	510	400	510	770	18,5	720x350x500	22
	Potencia Potencia Мощность	Alimentação Alimentação Электропитание	Vueltas disco Giros Обороты диска	A	B	C	D	E	F	G	H	Peso netto Pésó líquido Вес нетто	Dimensiones embalaje Dimensoes embalagem Размеры упаковки	Peso bruto Pésó bruto Вес брутто

Dischi fette / Slicing discs DF



Dischi bastoncini / Julienne discs DQ



Dischi cubetti / Dicing discs PS



Dischi per sfilacciare / Shredding discs DT

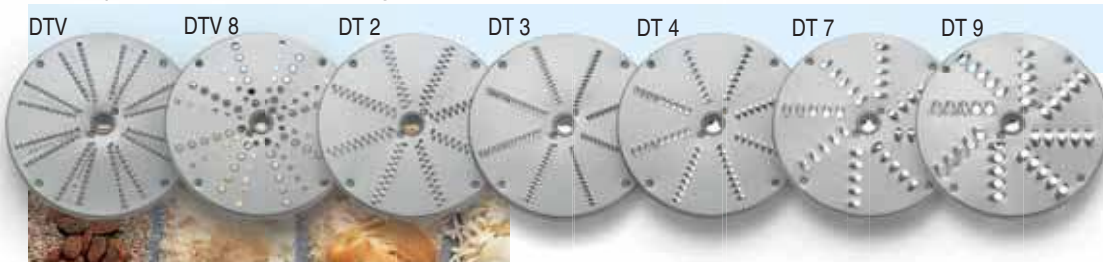

1. Coperchio in alluminio con apertura laterale.
Aluminium feed hopper lid with side opening



2. Scivolo per scarico continuo, con micro di sicurezza.
Chute for continuous product ejection, with safety microswitch.



3. Pulsantiera elettronica IP 54
Electronic push-button IP 54



4. Pulitore per dischi PS
PS dicing disc cleaner



5. Porta dischi
Discs holder



TM-TG

tagliaverdure

vegetable cutters



- TM-TG è una versione dello storico TM che, grazie alla nuova tramoggia gigante di introduzione prodotto, sfrutta al massimo la potenza del motore e la solida struttura del TM.
 - Caratteristiche funzionali ed elettriche come TM
 - Compatibilità tutti dischi TM esclusi i PS che sono dedicati.
 - Coperchio alluminio-inox con carico a 360°.
 - Leveraggio per sollevamento e rotazione pressore con micro.
 - Tubo introduzione senza micro.
 - Esclusivo disegno della tramoggia per eliminare vite rompitorsole centrale sul disco.
 - GRANDE FACILITA' DI CARICO.
- TM-TG is a version of the well-known TM that thanks to a new larger feed hopper maximizes the motor power and strong structure.*
- Same operational and electrical features of the TM .
 - TM discs compatible, except PS discs .
 - Aluminum-Stainless steel top with 360° loading feature.
 - Microswitch on lever.
 - Exclusive hopper design with no central chopping wedge.
 - VERY EASY PRODUCT LOADING.



PS 20G PS 14G PS 10G PS 8G



1. Dischi PS specifici per TM-TG
Special PS discs for TM-TG

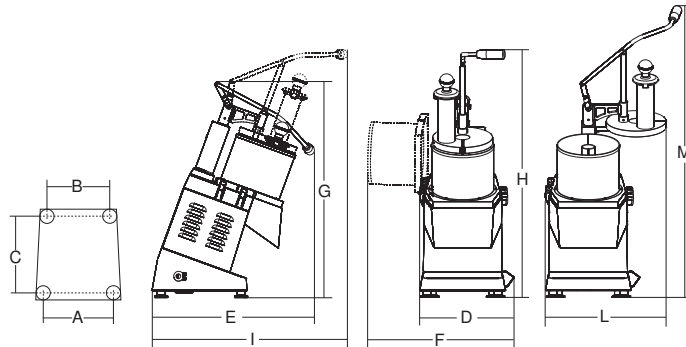

	Potenza Power Spannung Puissance	Alimentazione Power source Betriebsspannung Alimentation	Giri disco Disc revolutions Kreisläufe Tours Disques	A	B	C	D	E	F	G	H	I	L	M	Peso neto Net weight Nettogewicht Poids net	Dimensioni imballo Shipping Verpack, abmessungen Dim. emballage	Peso lordo Gross weight Bruttogewicht Poids brut
	watt/Hp	r.p.m.	r.p.m.	mm	mm	mm	mm	mm	mm	mm	mm	mm	mm	mm	kg	mm	kg
TM-TG	515 /0,7	230-400V/50Hz	300	225	195	255	296	509	460	676	777	612	428	915	20	720x350x800	24

Potencia
Potência
Мощность
功率

Alimentación
Alimentação
Электронпитание
電源

Vueltas disco
Giros
Обороты
刀盘转速

A B C D E F G H I L M

Peso neto
Peso líquido
Bec netto
淨重

Dimensiones embalaje
Dimensões embalagem
Paakepa ypacовки
包裝尺寸

Peso bruto
Peso brutto
Брутто
毛重





BLITZ

cutter bowl cutter



- Basamento e vasca in ABS termoresistente
- Coperchio in policarbonato con foro per l'aggiunta di ingredienti durante la lavorazione
- Coperchio e vasca interbloccati ma facilmente smontabili per le operazioni di pulizia
- Freno motore
- Comandi con NVR 24 volt IP 67

In dotazione:

- Mozzo con coltelli in acciaio inox
- Mozzo per montare in ABS
- Paletta

Opzionale

- Pala raschiatrice smontabile

- Base-plate and reservoir in heat-resistant ABS
- Lid in polycarbonate with hole to add the ingredients during processing
- Interlocked lid and reservoir, easy to disassemble though for cleaning
- Motor brake
- Control with NVR 24 Volt IP 67

Included items:

- Hub with cutting knives in stainless steel
- Hub for ABS assembly
- Scoop

Optional

- Dismountable scraping blade



1. Pala raschiatrice smontabile, opzionale
Optional dismountable scraping blade

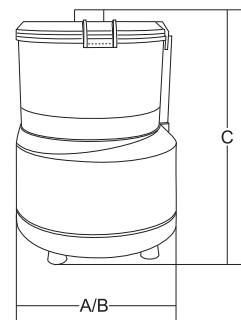

	Potenza Power Spannung Puissance	Alimentazione Power source Betriebsspannung Alimentation	Capacità vasca Bowl capacity Becken Kapazität Capacité cuve	Giri Revolutions Umdrehungen messers Tours	A	B	C	Peso netto Net weight Nettogewicht Poids net	Dimensioni imballo Shipping Verpack. abmessungen Dim. emballage	Peso lordo Gross weight Bruttogewicht Poids brut
	watt/HP		lt	r.p.m.	mm	mm	mm	Kg	mm	kg
Blitz	370/0,5	230V 50/60Hz F+N	3,2	2800	240	240	355	8	337x435x275	9
	Potencia Potência Мощность 功率	Alimentación Alimentação Электропитание 電源	Capacidad línea Capacidade recipiente Объем бункера 容量 容積	Vueltas Gros Обороты 转速	A	B	C	Peso neto Peso líquido Вес нетто 淨重	Dimensiones embale Dimensões embalagem Размеры упаковки 包裝尺寸	Peso bruto Peso bruto Вес брутто 毛重



CUTTER

cutter bowl cutters

- Robusta struttura in acciaio inox AISI 430.
 - Motore e vasca affiancati che permettono di isolare dal calore il prodotto lavorato (non su C15 da pavimento).
 - Vasche in acciaio inox con fondo termico e manici.
 - Motori ventilati ad alto rendimento per uso continuo.
 - Robusti coltelli a lame curve in acciaio temprato da coltelleria.
 - Sicurezza garantita da un sistema a doppio microinterruttore sul coperchio.
 - Coperchio in Lexan trasparente che permette ottima visibilità durante la lavorazione.
 - Foro di aggiunta ingredienti su coperchio.
 - Variotronic: variatore di velocità stabilizzato con controllo di potenza.
 - Modelli C4-6-9 disponibili con variatore continuo di velocità (di serie su C9).
 - Modello C15 da banco disponibile con 2 velocità.
 - Modello C15 Hp 7 con variatore ad inverter di serie.
 - In dotazione: spatola e piastra affilatura lame.
 - Opzionali mozzi con lame: dentate, forate, per pesto, per impasti.
- *Strong AISI 430 steel construction.*
 - *Detached motor and bowl for a better thermal insulation.*
 - *S/S bowl with handles and heavy bottom.*
 - *High efficiency ventilated motor for continuous operation.*
 - *Strong cutlery steel knives.*
 - *Safe operations ensured by a system of micro switches on the lid.*
 - *See-through lexan lid.*
 - *Lid with opening to add ingredients during operation.*
 - *Variotronic: speed control with stabilizer.*
 - *C4, C6 and C9 available with steplessly variable-speed drive.*
 - *C15 available with 2 speeds.*
 - *C15 HP7 with steplessly variable-speed drive and inverter as a standard.*
 - *Standard: spatula and sharpening stones.*
 - *Optional: serrated knives, emulsifying knives, knives for pesto sauce and knives to mix dough.*



C4



1. Lame per impasto
Shaft with knives to mix dough
2. Lame di serie
Shaft with regular knives
3. Lame dentate
Shaft with serrated knives
4. Lame forate
Shaft with emulsifying knives
5. Lame pesto
Shaft with knives for pesto sauce
6. Lame pesto per C15
C15 shaft with knives for pesto sauce

NEW
VARIOTRONIC™
SYSTEM



C 15



C 15 DA BANCO



C 9 VV



C4 - C6



C4 VV - C6 VV - C9 VV



C15



C4 - C6 Variotronic

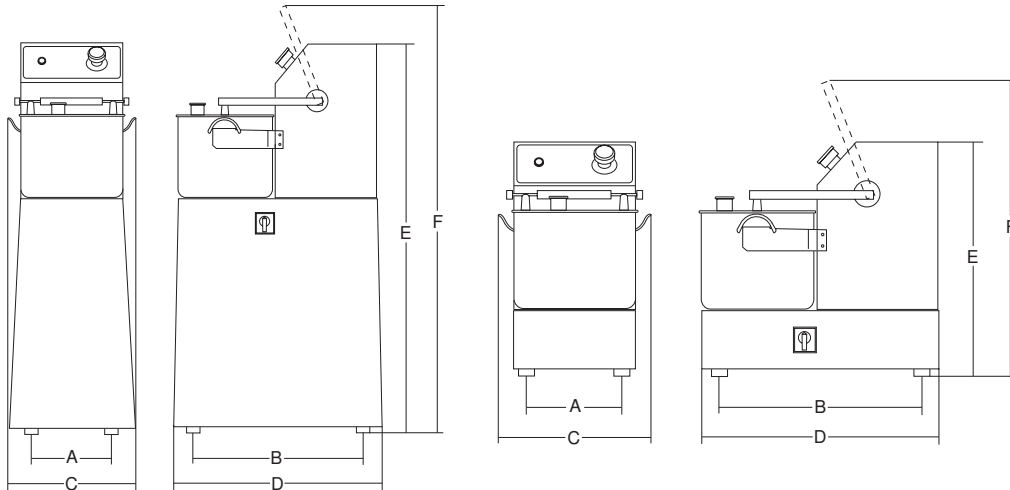

7. Vasca in acciaio inox 18/10 con fondo termodiffusore facile da svuotare e da pulire
Stainless steel 18/10 bowl with thermal diffuser
bottom, easy to empty and to clean

	Potenza Power Spannung Puissance	Alimentazione Power source Betriebsspannung Alimentation	Capacità vasca Bowl capacity Becken Kapazität Capacité cuve	Capienza utile vasca Bowl filling level Becken Nutzfläche Kapazität Capacité utile cuve	Giri Revolutions Umdrehungen messers Tours	A	B	C	D	E	F	Peso netto Net weight Nettogewicht Poids net	Dimensioni imballo Shipping Verpack. abmessungen Dim. emballage	Peso lordo Gross weight Bruttogewicht Poids brut
	watt/HP		lt	lt	r.p.m.	mm	mm	mm	mm	mm	mm	Kg	mm	kg
C4	350/0,5	230V 50/60Hz F+N	3,3	1,5	2800	160	310	305	365	255	-	10	450x330x310	11
C4 VV	350/0,5	230V 50/60Hz F+N	3,3	1,5	1500÷2800	160	310	305	365	255	-	10	450x330x310	11
C4 VT	350/0,5	230V 50/60Hz F+N	3,3	1,5	500÷2500	160	310	305	365	255	-	10	450x330x310	11
C6	350/0,5	230V 50/60Hz F+N	5,3	3,1	2800	160	310	305	365	320	-	11	450x330x400	12
C6 VV	350/0,5	230V 50/60Hz F+N	5,3	3,1	1500÷2800	160	310	305	365	320	-	11	450x330x400	12
C6 VT	350/0,5	230V 50/60Hz F+N	5,3	3,1	500÷2500	160	310	305	365	320	-	11	450x330x400	12
C9 VV	350+350/0,5+0,5	230V 50/60Hz F+N	9,4	5,4	1500÷2800	225	410	355	455	380	-	23	720x350x500	25
C 15 da banco	2940/4	400V 50/60 Hz 3F	14,5	8,2	2800	265	480	380	610	530	700	52	720x570x770	67
C 15 2V da banco	1470+2200/2+3	400V 50/60 Hz 3F	14,5	8,2	1400/2800	265	480	380	610	530	700	52	720x570x770	67
C 15	2940/4	400V 50/60 Hz 3F	14,5	8,2	2800	340	400	420	445	1030	1130	66	600x600x1150	75
C 15 2V	1470+2200/2+3	400V 50/60 Hz 3F	14,5	8,2	1400/2800	340	400	420	445	1030	1130	66	600x600x1150	75
C 15 Macelleria/For meat	2940/4	400V 50/60 Hz 3F	14,5	8,2	2800	340	400	420	445	1030	1130	66	600x600x1150	75
C 15 Pasticceria/ For thick mixes	5150/7	400V 50/60 Hz 3F	14,5	8,2	1200÷1800	340	400	420	445	1030	1130	66	600x600x1150	75



C 6



ATHOS

tagliamozzarella mozzarella cutter

- Macchina robusta, compatta, di grande rendimento e potenza, costruita in acciaio inox e alluminio anodizzato.
 - Campana porta dischi in alluminio lucidato, completamente smontabile per la pulizia;
 - Lame e dischi in acciaio da coltelleria e alluminio;
 - Tramoggia in acciaio inox;
 - Trasmissione a cinghia piatta Poliv;
 - Protezione su bocca campana in ABS con micro magnetico;
 - Pulsantiera elettronica a 24 V con dispositivo NVR.
- *Strong compact heavy-duty grater, made of stainless steel and anodized aluminium.*
 - *Polished aluminium disc holder is completely removable for cleaning.*
 - *Cutlery steel and aluminium grating discs.*
 - *Stainless steel tray.*
 - *Poly-V belt drive.*
 - *Guard on disc holder opening.*
 - *24 V electronic push-button panel with NVR.*



1. Dischi removibili
Removable grating discs



2. Protezione su bocca campana in ABS con micromagnete.
ABS Guard with micromagnet on disc holder opening.



3. Protezione inferiore
Underside motor protection plate



4. Dischi intercambiabili
Exchangeable discs

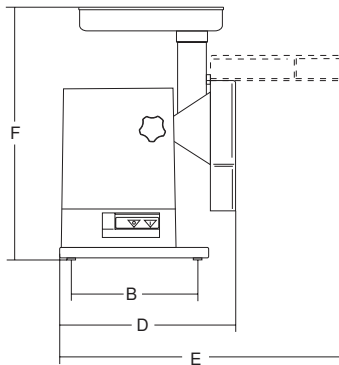
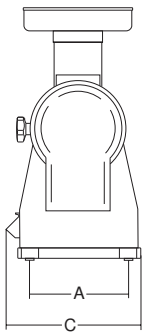

	Potencia Power Spannung Puissance	Alimentazione Power source Betriebsspannung Alimentation	Giri disco Disc revolutions Revolutions tours/Disque	A	B	C	D	E	F	Peso netto Net weight Nettogewicht Poids net	Dimensioni imballo Shipping Verpack. abmessungen Dim. emballage	Peso lordo Gross weight Bruttogewicht Poids brut
	watt/Hp		r.p.m.	mm	mm	mm	mm	mm	mm	Kg	mm	kg
Athos	210-0,30	230V-400V/50HZ	400	150	260	230	370	570	480	14	500x300x550	17

Potencia
Potência
Мощность
功率

Alimentación
Alimentação
Электропитание
电源

Vueltas disco
Giros
Обороты, диска
刀蓋轉量

A B C D E F

Peso netto
Peso líquido
Вес нето
淨重

Dimensiones embalaje
Dimensões embalagem
Размеры упаковки
包裝尺寸

Peso bruto
Peso bruto
Вес брутто
毛重

STO RM

frullatori ad immersione hand-held mixers



- Efficiente sistema di raffreddamento del motore per un utilizzo prolungato
- Robusta ma leggera struttura portante in ABS caricato a vetro
- Pratica ed ergonomica impugnatura
- Disponibile con velocità fissa o variabile
- Macchina protetta con grado IP x3
- Rapido sistema di aggancio asta
- Coltello a tre lame in acciaio da coltelleria

- *Highly effective cooling system.*
- *Sturdy and light weight fiberglass ABS body.*
- *Ergonomic handle.*
- *Fixed and variable speed controls available.*
- *IPX3 protection.*
- *Quick coupling device.*
- *Cutlery steel knives.*

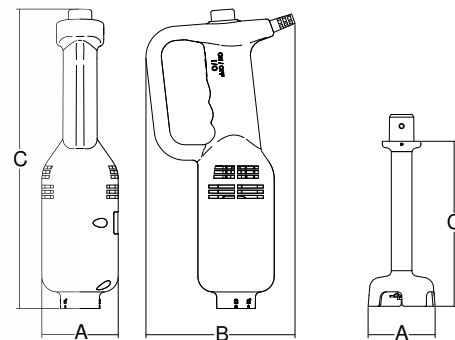

	Potenza Power Spannung Puissance	Alimentazione Power source Betriebsspannung Alimentation	Giri coltelli Knives revolutions Umdrehungen messers Tours couteaux	Capacità di lavoro Working capacity Arbeitsfähigkeit Capacité de travail	A	B	C	Peso netto Net weight Nettogewicht Poids net	Dimensioni imballo Shipping Verpack abmessungen Dim. emballage	Peso lordo Gross weight Brutogewicht Poids brut
	watt/Hp		r.p.m.	lt	mm	mm	mm	Kg	mm	kg
Storm	200/0,27	230V/50Hz	12.500	15	74	145	290	1,1	225x560x140	2
Storm VV	200/0,27	230V/50Hz	2.000 ÷ 12.500	15	74	145	290	1,1	225x560x140	2
Asta 16	-	-	-	-	ø 65	-	160	0,20	-	-

Potencia
Potencia
Мощность
功率

Alimentación
Alimentação
Электропитание
電源

Vueltas cuchillos
Giros lâminas
Скорость вращения ножей
刀片转速

Capacidad de trabajo
Capacidade de trabalho
Объем
工作能力

A

B

C

Peso neto
Pésó líquido
Вес нетто
净重

Dimensiones embalaje
Dimensões embalagem
Размеры упаковки
包装尺寸

Peso bruto
Pésó bruto
Вес брутто
毛重



1. Pratico sgancio asta
Shaft easy to remove



CICLO NE

frullatori ad immersione hand-held mixers

- Efficiente sistema di raffreddamento motore
- Robusta ma leggera struttura portante in ABS caricato a vetro
- Pratica ed ergonomica impugnatura
- Disponibile con velocità fissa o variabile
- Sistema di sicurezza contro l'accensione accidentale
- Pulsante di bloccaggio motore acceso
- Disponibili in 3 diverse motorizzazioni
- Macchina protetta con grado IP x3
- Rapido sistema di aggancio asta
- Disponibili aste da 25 e 35 cm
- Coltello a tre lame in acciaio da coltelleria
- Optional: Supporto pentola, supporto a muro, frusta. Frusta con sistema di ingranaggi in metallo
- Fruste inox smontabili e pulibili in lavastoviglie.



CICLONE 36



YouTube



- Highly effective cooling system.
- Sturdy and light weight fiberglass ABS body.
- Ergonomic handle.
- Fixed and variable speed controls available.
- Safety device preventing switching on by mistake.
- Trigger switch for continuous blending.
- Powered by 3 different motors.
- IPX3 protection.
- Quick coupling device.
- Shafts available in 2 length: 25, 35 cm.
- Cutlery steel knives.
- Optional: Pot support, wall attachment, whisk. Whisk with metal gearing.
- Demountable and dishwashing safe whisk.

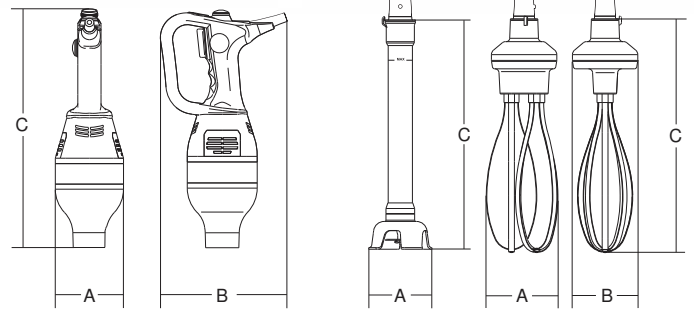

	Potenza Power Spannung Pulsance	Alimentazione Power source Betriebsspannung Alimentation	Giri coltelli Knives revolutions Umdrehungen messers Tours couteaux	Giri frusta Whisk revolutions Umdrehungen Schneebesen Tours fouet	Capacità di lavoro Working capacity Arbeitsfähigkeit Capacité de travail	A	B	C	Peso netto Net weight Nettogewicht Poids net	Dimensioni imballo Shipping Verpack. abmessungen Dim. emballage	Peso lordo Gross weight Bruttogewicht Poids brut
	watt/Hp		r.p.m.	r.p.m.	lt	mm	mm	mm	Kg	mm	kg
Ciclone 20	200/0,27	230V/50Hz	12.000	2.300	20	100	182	340	2	440x330x150	3
Ciclone 20 VV	200/0,27	230V/50Hz	1.000÷12.000	1.900÷2.700	20	100	182	340	2	440x330x150	3
Ciclone 28	280/0,38	230V/50Hz	12.000	2.300	40	100	182	340	2,2	440x330x150	3,2
Ciclone 28 VV	280/0,38	230V/50Hz	1.000÷12.000	1.900÷2.700	40	100	182	340	2,2	440x330x150	3,2
Ciclone 36	360/0,50	230V/50Hz	12.000	2.300	70	100	182	348	2,5	440x330x150	3,5
Ciclone 36 VV	360/0,50	230V/50Hz	1.000÷12.000	1.900÷2.700	70	100	182	348	2,5	440x330x150	3,5
Asta 25	-	-	-	-	-	ø 94	-	250	0,5	-	-
Asta 35	-	-	-	-	-	ø 94	-	320	0,7	-	-
Frusta	-	-	-	-	-	106	113	348	1,1	520x210x250	2

Potencia
Potência
 Мощность
 功率

Alimentación
Alimentação
Электропитание
电源

Vueltas cuchillos
Giros lâminas
Обороты ножей
刀片转速

Speed of rotation of blades
Скорость вращения ножей



CICLONE 28

Vueltas batidor
Giros batedor
Обороты Венчик
搅拌器转速

Capacity of work
Capacidade de trabalho
Объем
工作能力



CICLONE 20

Peso líquido
Peso líquido
Вес нетто
净重

Dimensiones embalaje
Dimensões embalagem
Размеры упаковки
包装尺寸

Peso bruto
Peso bruto
Вес брутто
毛重



CICLONE 36



YouTube



VO RTEX

frullatori ad immersione hand-held mixers

- Efficiente sistema di raffreddamento motore.
- Robusta ma leggera struttura portante in ABS caricato a vetro.
- Pratica ed ergonomica impugnatura.
- Paracolpi in gomma per attutire il contatto con i recipienti.
- Motori potenti e prestanti.
- Disponibile in tre versioni di comandi:
Velocità fissa.
Velocità variabile al dito.
Variotronic: variatore di velocità stabilizzato con controllo di potenza.
- Sistema di sicurezza contro l'accensione accidentale.
- Pulsante di bloccaggio motore acceso.
- Disponibili in 3 diverse motorizzazioni.
- Macchina protetta con grado IP x3.
- Rapido sistema di aggancio asta.
- Scelta fra 2 differenti lunghezze di aste: 35 e 45 cm.
- Aste totalmente smontabili per una pulizia approfondita che ne prolunga la durata.
- Mozzo e campana completamente in acciaio inox.

- *Highly effective cooling system.*
- *Sturdy and light weight fiberglass ABS body.*
- *Ergonomic handle.*
- *Rubber buffer between motor and shaft.*
- *High efficiency motors.*
- *3 controls available:*
One speed.
Drill like speed control.
Variotronic: speed control with stabilizer.
- *Safety device preventing switching on by mistake.*
- *Trigger switch for continuous blending.*
- *3 different motors.*
- *IPX3 protection.*
- *Quick coupling device.*
- *Shafts available in 2 length: 35 and 45 cm.*
- *Completely demountable shafts for an accurate cleaning and a longer life.*
- *Completely stainless steel shaft and bell.*



VORTEX 43



VORTEX 43



VORTEX 55



VORTEX 75



1. Sgancio frusta
Whisk release



2. Supporto a muro
Wall support



3. Supporto pentola
Bowl support



4.



Frusta
Whisk

Asta 35
Shaft 35

Asta 45
Shaft 45

• **Opzionali:**

- Valigetta.
- Supporto pentola.
- Supporto a muro.
- Espositore.
- Frusta.
- Frusta con sistema di ingranaggi in metallo.
- Fruste inox smontabili e pulibili in lavastoviglie.

• **Optional:**

- Storage case.
- Bowl support.
- Wall support.
- Exposition shelf.
- Whisk.
- Whisk metal gears.
- Demountable and dishwashing safe whisk.

5.

7. Coltelli smontabili
Removable knives



8. Asta smontabile
Removable shafts

6.

4. Espositore Vortex
Dimensioni: mm 800x650 h.2350
5. Supporto a muro
6. Valigetta trasporto del Vortex

Vortex stand
Overall dimensions mm 800x650 h.2350
Wall support
Vortex container



9. Impugnatura ergonomica
Ergonomic handle



10. Dispositivo di sicurezza per l'accensione
Safety device for the machine switch on



11. Variatore di velocità con stabilizzatore
Speed control with stabilizer



12. Griglie di ventilazione
Air intake



13. Aggancio rapido utensili
Quick tool assembly



14. Campana e coltelli inox
Bell and knives of stainless steel

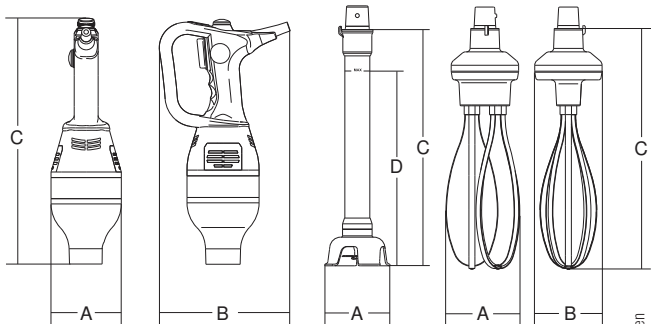

NEW
VARI-TRONIC™
SYSTEM

	Potenza Power Spannung Puissance	Alimentazione Power source Betriebsspannung Alimentation	Giri coltelli Knives revolutions Umdrehungen messers Tours couteaux	Giri frusta Whisk revolutions Umdrehungen Schneebesen Tours fouet	Capacità di lavoro Working capacity Arbeitsleistung Capacité de travail	A	B	C	D	Peso netto Net weight Nettogewicht Poids net	Dimensioni imballo Shipping Verpack. abmessungen Dim. emballage	Peso lordo Gross weight Bruttogewicht Poids brut
	watt/HP	230V/50Hz	r.p.m.	r.p.m.	lt	mm	mm	mm	mm	Kg	mm	kg
Vortex 43	430/0,60	230V/50Hz	12.500	1.800	100	125	190	377	-	2,5	230x270x430	3
Vortex 43 VV	430/0,60	230V/50Hz	0 ÷ 12.500	400 ÷ 1.800	100	125	190	377	-	2,5	230x270x430	3
Vortex 43 VT	430/0,60	230V/50Hz	2.000 ÷ 11.500	-	100	125	190	377	-	2,5	230x270x430	3
Vortex 55	550/0,80	230V/50Hz	13.000	1.800	200	125	190	385	-	3,5	230x270x430	3,7
Vortex 55 VV	550/0,80	230V/50Hz	0 ÷ 13.000	400 ÷ 1.800	200	125	190	385	-	3,5	230x270x430	3,7
Vortex 55 VT	550/0,80	230V/50Hz	2.000 ÷ 11.500	-	200	125	190	385	-	3,5	230x270x430	3,7
Vortex 75	750/1,00	230V/50Hz	13.000	1.800	300	125	190	390	-	4	230x270x430	4,5
Vortex 75 VV	750/1,00	230V/50Hz	0 ÷ 13.000	400 ÷ 1.800	300	125	190	390	-	4	230x270x430	4,5
Vortex 75 VT	750/1,00	230V/50Hz	2.000 ÷ 11.500	-	300	125	190	390	-	4	230x270x430	4,5
Asta 35	-	-	-	-	-	∅ 100	-	415	350	1,2	490x230x150	1,8
Asta 45	-	-	-	-	-	∅ 100	-	515	450	1,6	590x230x150	2,1
Frusta	-	-	-	-	-	117	113	385	-	1,2	520x210x250	1,6

Potencia
Potência
Мощность
功率

Alimentação
Alimentação
Электроснабжение
电源

Vuelvas cuchillos
Gros. lâminas
Скорость вращения
шпатель
刀片转速

Vuelvas batidor
Gros. batedor
Обороты в минуту
搅拌器转速

Capacidad de trabajo
Capacidade de trabalho
Объем
工作能力

A

B

C

D

Peso netto
Pésó líquido
Вес нетто
净重

Dimensiones embalaje
Dimensões embalagem
Размеры упаковки
包裝尺寸

Peso bruto
Pésó bruto
Вес брутто
毛重



PPJ - LCJ

pelapatate - lavacozze potato peelers - mussels cleaner

- Costruzione in acciaio inox AISI 304.
- Sistema di trasmissione con cinghia poliV autotensionante.
- Potenti motori ventilati per uso continuo.
- Fondello abrasivo in inox bugnato.
- Pareti abrasive PP con mantello facilmente sostituibile dall'operatore.
- Vasca e fondello abrasivo facilmente asportabili senza attrezzi e lavabili in lavastoviglie (brevettato).
- Sistema di scarico patate automatico.
- Bocca di scarico in acciaio inox con fissaggio rapido e chiusura ermetica.
- Piedini inox regolabili e fissabili a pavimento.
- Facile manutenzione per accesso immediato a tutti i componenti senza ribaltare la macchina.
- **Versione CE con:**
Microinterruttore su coperchio
Microinterruttore su sportello scarico
- **Versioni disponibili ad una velocità modelli 6, 10 e 20:**
Pelapatate (PPJ).
Lavacozze (LCJ) senza abrasivo alle pareti.
- **Versioni disponibili a due velocità (solo versione 10):**
Pelapatate/Lavacozze (PP/LC) necessita due vasche.
Pelapatate/Asciugaverdura (PP/AV) necessita cestello.
- **Opzionali:**
Cestello asciugaverdure (solo versione 10)
Convogliatore porta sacchetto.
Attacco rapido entrata acqua.
Cavalletto e setaccio inox.



PPJ 10

PPJ 20

- Made from AISI 304 Stainless steel.
- Self-tensioning poli-V belt drive.
- High efficiency ventilated motors for continuous operation.
- Stainless steel peeling disc.
- Easy to replace abrasive surface.
- Patented removable dishwashing safe container and bottom peeling disc (no tools required)
- Automatic unloading system.
- Stainless steel outlet opening with quick and sealed locking.
- Adjustable S/S feet can be fixed to the floor.
- Easy service and easy access to the components.
- **CE version with:**
Microswitch on the lid
Microswitch on outlet opening
- **One speed version 6, 10 and 20:**
Potato peeler (PPJ).
Shell washer (LCJ) without abrasive surfaces.

- **2 speeds version 10:**
Potato peeler/ shell washer (PP/LC) requires 2 containers.
Potato peeler/vegetable drier (PP/AV) requires drier basket.
- **Optional:**
Vegetable drier basket (only version 10).
Longer opening for shopping bags.
Fast water inlet connection.
S/S trestle and sieve.



PPJ 6

PPJ 6

PPJ 10 SC



1. Cesto asciugaverdura
Vegetable drier basket



2. Attacco rapido entrata acqua
Fast connection/remove of water entry



3. Cavalletto con filtro opzionale
Optional trestle with sieve



4. Convogliatore porta sacchetto
Longer opening for shopping bags



5. Comandi 24 Volt PPJ 2V
PPJ 2V 24Volt controls

PPJ SC - LCJ SC

- Made from AISI 304 Stainless steel.
- Poli-V belt drive.
- High efficiency ventilated motors for continuous operation.
- Stainless steel peeling disc.
- Easy to replace abrasive surface.
- Patented removable dishwashing safe container and bottom peeling disc (no tools required)
- Automatic unloading system.
- Stainless steel outlet opening with quick and sealed locking.
- Adjustable S/S feet can be fixed to the floor.
- Drain filter option available.

CE version with:

- Microswitch on the lid.
- Microswitch on outlet opening.

Versions available:

- Potato peeler (PPJ).
- Shell washer (LCJ) without abrasive surfaces.

PPJ SC - LCJ SC

- Costruzione in acciaio inox AISI 304.
- Sistema di trasmissione con cinghia poliV.
- Potenti motori ventilati per uso continuo.
- Fondello abrasivo in inox bugnato.
- Pareti abrasive PP con mantello facilmente sostituibile dall'operatore.
- Vasca e fondello abrasivo facilmente asportabili senza attrezzi e lavabili in lavastoviglie (brevettato).
- Sistema di scarico patate automatico.
- Bocca di scarico in acciaio inox con fissaggio rapido e chiusura ermetica.
- Filtro su scarico opzionale.

Versione CE con:

- Microinterruttore su coperchio.
- Microinterruttore su sportello scarico.

Versioni disponibili:

- Pelapatate (PPJ).
- Lavacozze (LCJ) senza abrasivo alle pareti.



PPJ 6 SC



PPJ 10 - 20 SC

PPJ/LCJ 6

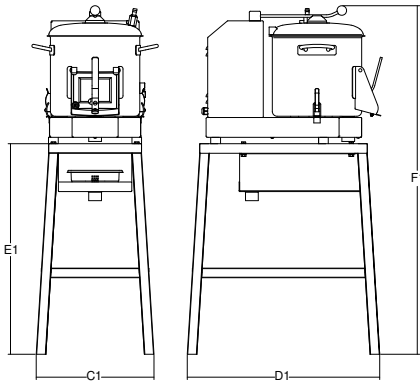

PPJ/LCJ 6

C1 = mm 370
D1 = mm 600
E1 = mm 660
F1 = mm 1090

PPJ/LCJ 6-10-20 SC

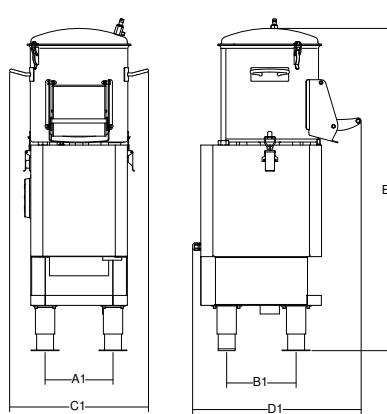

PPJ/LCJ 6 SC

A1 = mm 200
B1 = mm 240
C1 = mm 400
D1 = mm 400
E1 = mm 790

PPJ/LCJ 10 SC

A1 = mm 225
B1 = mm 230
C1 = mm 470
D1 = mm 544
E1 = mm 1070

PPJ 20 SC

A1 = mm 330
B1 = mm 310
C1 = mm 560
D1 = mm 650
E1 = mm 1210

PPJ/LCJ 10-20

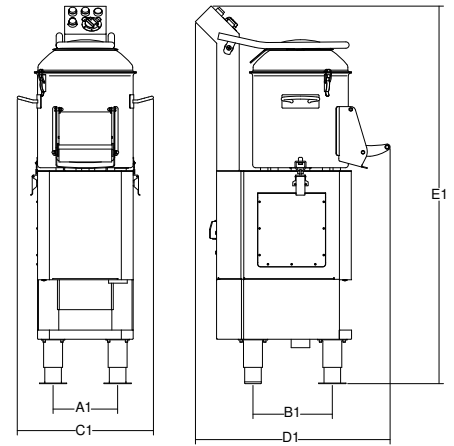

PPJ/LCJ 10

A1 = mm 220
B1 = mm 270
C1 = mm 470
D1 = mm 775
E1 = mm 1276

PPJ/LCJ 20

A1 = mm 300
B1 = mm 300
C1 = mm 560
D1 = mm 880
E1 = mm 1360

PPJ/LCJ 6

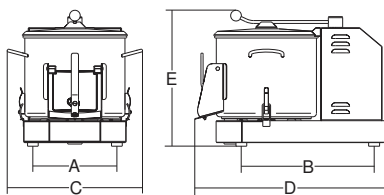

PPJ/LCJ 6-10-20 SC

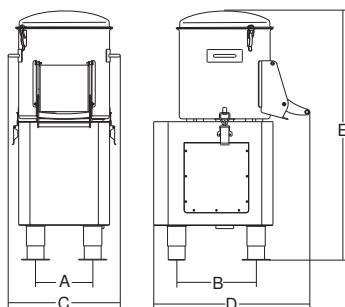

PPJ/LCJ 10-20

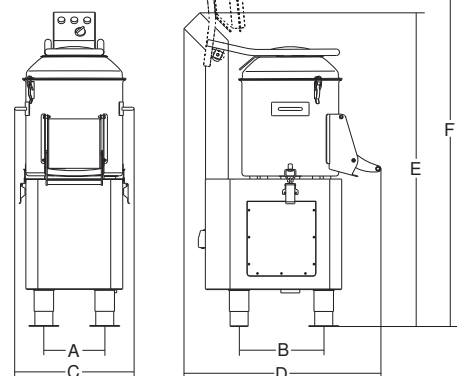

	Potenza Power Spannung Puissance	Alimentazione Power source Betriebsspannung Alimentation	Giri Revolutions Umdrehungen Tours	Capacità Capacity Kapazität Capacité	Produzione oraria Output/h. Leistung/h. Débit/h.	A	B	C	D	E	F	Peso netto Net weight Nettogewicht Poids net	Dimensioni imballo Shipping Verpack. abmessungen Dm. emballage	Peso lordo Gross weight Bruttogewicht Poids brut
	watt/Hp		r.p.m.	Kg/lt	Kg/h.	mm	mm	mm	mm	mm	mm	Kg	mm	kg
PPJ 6 SC	370/0,50	230V/50Hz	320	6/10	105	220	260	400	400	690	-	23	720x570x1020	35
PPJ 6	370/0,50	230V/50Hz	320	6/10	105	260	320	400	550	440	-	31	500x630x650	36
PPJ 10 SC	735/1	230-400V/50Hz	320	10/20	170	203	282	470	544	910	-	41,5	720x570x1200	51,5
PPJ 10	735/1	230-400V/50Hz	320	10/20	170	203	282	470	775	1050	1310	51	720x570x1200	61
PPJ 10 2V PP/LC	368 - 662 / 0,50 - 0,90	400V/50Hz	160/320	10/20	170	203	282	470	775	1050	1310	52	720x570x1200	62
PPJ 10 2V PP/AV	368 - 552 / 0,50 - 0,75	400V/50Hz	320/450	10/20	170	203	282	470	775	1050	1310	52	720x570x1200	62
PPJ 20 SC	1102/1,5	230-400V/50Hz	275	20/35	340	295	337	560	650	1040	-	52	640x760x1400	62
PPJ 20	1102/1,5	230-400V/50Hz	275	20/35	340	295	337	560	880	1190	1545	58	640x760x1400	68
LCJ 6 SC	370/0,50	230V/50Hz	150	6/10	-	220	260	400	400	690	-	23	720x570x1020	35
LCJ 6	370/0,50	230V/50Hz	150	6/10	-	260	320	400	550	440	-	31	500x630x650	36
LCJ 10 SC	735/1	230-400V/50Hz	150	10/20	170	203	282	470	544	910	-	41,5	720x570x1200	61
LCJ 10	735/1	230-400V/50Hz	150	10/20	170	203	282	470	775	1050	1310	51	720x570x1200	61
LCJ 20	1102/1,5	230-400V/50Hz	150	20/35	340	295	337	560	880	1190	1545	58	640x760x1400	68

Potencia
Potência
Мощность
功率

Alimentación
Alimentação
Электроснабжение
電源

Vueltas
Giros
轉數
Обороты

Capacidad
Capacidade
Вместимость
容積

Producción/h.
Produção/h.
Часовая производительность
产量/小时

A

B

C

D

E

F

Peso netto
Peso líquido
Вес нетто
淨重

Dimensiones embalaje
Dimensões embalagem
Размеры упаковки
包裝尺寸

Peso bruto
Peso bruto
Вес брутто
毛重



GP - GF

grattugie cheese graters



- Macchine semplici e compatte.
- Costruzione in alluminio pressofuso lucidato.
- Motore ventilato (solo GF).
- Rullo in acciaio trattato per uso alimentare.
- Disponibile rullo inox opzionale (solo GF).

- Simple and compact machines.
- Made from diecasted polished aluminium.
- Ventilated motor (only GF).
- Galvanized steel drum.
- S/S drum available on demand (only GF).

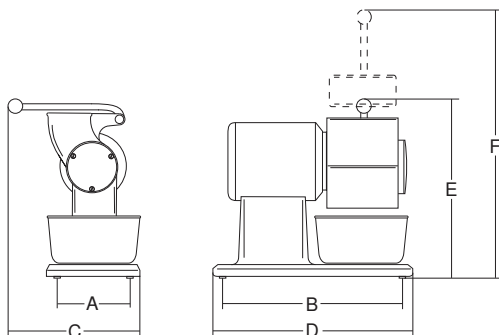

1. Griglia di protezione/rullo
inox per GF
Protection grate/stainless steel drum
for GF



2. Microinterruttore su grattugia
Microwitch on the grater

	Potenza Power Spannung Puissance	Alimentazione Power source Betriebsspannung Alimentation	Giri rullo Drum revolutions Walze Kreislauf Tours rouleauté	Dim. bocca Mouth dimensions Öffnung Größe Dimensions bouche	A	B	C	D	E	F	Peso netto Net weight Nettogewicht Poids net	Dimensioni imballo Shipping Verpack. abmessungen Dim. emballage	Peso lordo Gross weight Bruttogewicht Poids brut
	watt/Hp		r.p.m.	mm	mm	mm	mm	mm	mm	mm	Kg	mm	kg
GP	380/0,50	230V/50Hz	1400	110x65	150	220	250	290	310	450	8	430x310x290	10
GF	588/0,80	230-400V/50Hz	1400	130x70	185	270	290	390	370	560	16	500x300x550	18
	Potencia Potência Мощность	Alimentación Alimentação Электропитание 電源	Giros rodillo Giros cilindro Обороты валика 滚筒转速	Dimensiones boca Dimensões boca Размеры загрузки. Горловины 料口尺寸	A	B	C	D	E	F	Peso netto Peso líquido Вес нетто 淨重	Dimensiones embalaje Dimensões embalagem Размеры упаковки 包裝尺寸	Peso bruto Peso bruto Вес брутто 毛重



GF VEGAS - GF DENVER

grattugie cheese graters

- Robusta struttura in alluminio anodizzato.
- Motore ventilato.
- Bocca grattugia smontabile in lega di alluminio lucidata e anodizzata.
- Rullo grattugia inox.

Versione CE con:

- Microinterruttori di sicurezza su vaschetta raccolta formaggio e leva.
- Comandi IP54 con NVR.

- Reliable anodized aluminium construction.
- Ventilated motor.
- Demountable anodized aluminium grating mouth.
- S/S drum.

CE version:

- Safety microswitches on lever and receiving tray.
- IP54 protection rated controls and NVR device.



GF DENVER

GF VEGAS

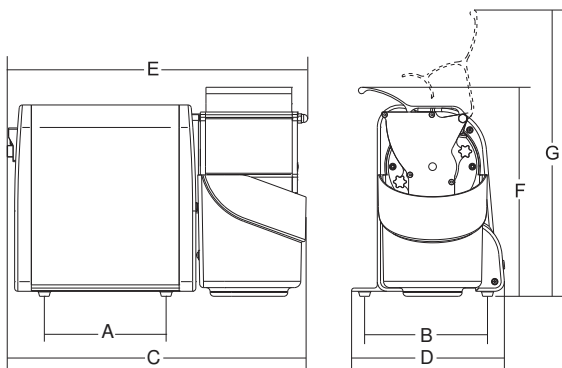

	Potenza Power Spannung Puissance	Alimentazione Power source Betriebsspannung Alimentation	Giri rullo Drum revolutions Walze Kreislauf Tours roulement	Dim. bocca Mouth dimensions Öffnung Größe Dimensions bouche	A	B	C	D	E	F	G	Peso netto Net weight Nettogewicht Poids net	Dimensioni imballo Shipping Verpack. abmessungen Dim. emballage	Peso lordo Gross weight Bruttogewicht Poids brut
	watt/Hp		r.p.m.	mm	mm	mm	mm	mm	mm	mm	mm	Kg	mm	kg
GF Vegas	250/0,30	230V/50Hz	1400	115x65	180	170	442	212	428	302	420	14	400x560x370	18
GF Denver	370/0,50	230V/50Hz	1400	135x65	190	190	465	238	468	325	444	15	620x340x450	19
	Potencia Potência Мощность 功率	Alimentación Alimentação Электропитание 電源	Giros rodillo Giros cilindro Обороты валика 滾筒轉速	Dimensiones boca Dimensões bocal Размеры запыя. Габариты 料口尺寸	A	B	C	D	E	F	G	Peso neto Peso líquido Бес нетто 淨重	Dimensiones embalaje Dimensões embalagem Размеры упаковки 包裝尺寸	Peso bruto Peso bruto Бес брутто 毛重

GF DAKOTA



grattugia cheese grater



- Corpo in alluminio anodizzato e fianchi in ABS antiurto.
- Generoso motore ventilato.
- Bocca grattugia in alluminio brillantato di grande capienza.
- Capiente e pratica vasca di raccolta prodotto in plexiglass trasparente.
- Rullo smontabile in acciaio inox.

Versione CE con:

- Comandi 24 volt con NVR.
- Dispositivo di sicurezza su vaschetta raccolta formaggio e leva.

- Anodized aluminium body and ABS shockproof sides.

- Ventilated motor.

- Large bright finished aluminium grating mouth.

- Large see-through plexiglass receiving tray.

- Demountable S/S drum.

CE version:

- 24 volt controls and NVR device.

- Safety microswitch on the receiving tray and the lever.

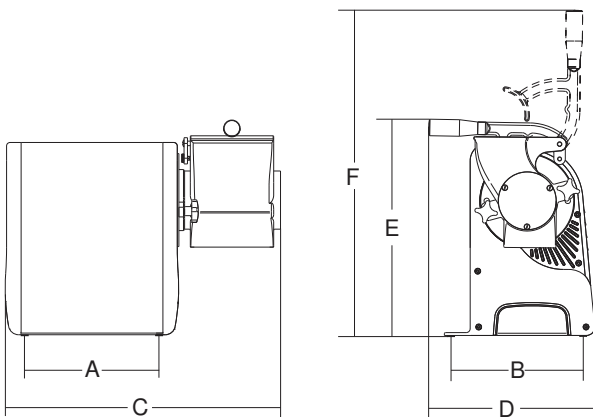

	Potenza Power Spannung Puissance	Alimentazione Power source Betriebsspannung Alimentation	Giri rullo Drum revolutions Walze Kreislauf Tours rouleteuté	Dim. bocca Mouth dimensions Öffnung Größe Dimensions bouche	A	B	C	D	E	F	Peso netto Net weight Nettogewicht Poids net	Dimensioni imballo Shipping Verpack abmessungen Dim. emballage	Peso lordo Gross weight Bruttogewicht Poids brut
	watt/Hp	r.p.m.	mm	mm	mm	mm	mm	mm	mm	mm	Kg	mm	kg
GF Dakota	1ph 750 / 1 3ph 1100 / 1,5	230-400V/50Hz	1400	140x80	225	215	500	300	400	580	20	630x430x450	22
	Potencia Potência Мощность	Alimentación Alimentação Электропитание 電源	Giros rodillo Giros cilindro Обороты валика 滾筒轉速	Dimensiones boca Dimensões bucal Размеры загрузки. Горловины 料口尺寸	A	B	C	D	E	F	Peso líquido Peso líquido Вес нетто 淨重	Dimensiones embalaje Dimensões embalagem Размеры упаковки 包裝尺寸	Peso bruto Peso bruto Вес брутто 毛重



GFX-GF

grattugie cheese graters

GFX 1.5-2

- Struttura totalmente realizzata in acciaio inox AISI 304.
- Robustezza e facilità di pulizia.
- Potenti motori ventilati per uso continuo.
- Capiente e pratica vasca di raccolta prodotto in plexiglass trasparente (inox opzionale).
- Rullo in acciaio inox.
- Bocca in lega di alluminio brillantata totalmente smontabile senza attrezzi per una profonda e accurata pulizia.
- **Versione CE:** Comandi 24 Volt IP 67 Freno motore, Microinterruttore di sicurezza su leva e su vasca raccolta formaggio.

GF HP4

- Macchina da laboratorio per grosse produzioni.
- Ampia bocca di carico in alluminio brillantato internamente.
- Rullo in acciaio inox.
- Potenti motori ventilati per uso continuo.
- Capiente e pratica vasca di raccolta prodotto.
- **Versione CE:** Comandi 24 Volt IP 54 Freno motore, Microinterruttore di sicurezza su leva e su vasca raccolta formaggio.

GFX 1.5-2

- Made from AISI 304 Stainless steel.
- Machine strong and easy to clean.
- High efficiency ventilated motors for continuous operation.
- Large see-through plexiglass receiving tray (s/ steel optiona).
- Stainless steel drum.
- Bright finished aluminium grating mouth.
- Demountable grating mouth for a thorough cleaning. (no tools required)
- **CE version:** IP 67 protection rate 24V controls, Motor break, Safety microswitches on lever and receiving tray.

GF HP4

- Heavy duty machine.
- Large bright finished aluminium grating mouth.
- Stainless steel drum.
- High efficiency ventilated motors for continuous operation.
- Large plexiglass receiving tray.
- **CE version:** IP 54 protection rate 24V controls, Motor break, Safety microswitches on lever and receiving tray.



GFX HP 2

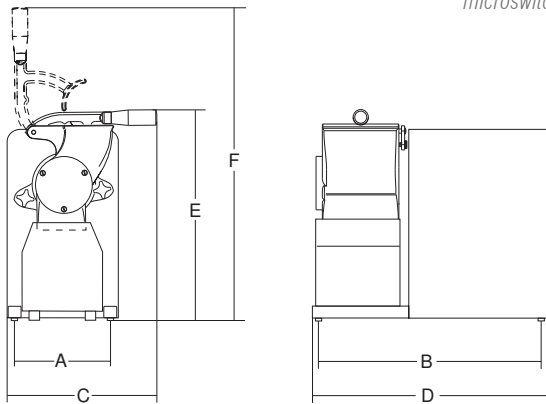

1. Vaschetta inox opzionale
Optional s/steel tray

GFX HP 1.5 - 2

	Potenza Power Spannung Puissance	Alimentazione Power source Betriebsspannung Alimentation	Giri rullo Drum revolutions Wätze Kreislauf Tours rouleauté	Dim. bocca Mouth dimensions Öffnung Größe Dimensions bouche	A	B	C	D	E	F	Peso netto Net weight Nettogewicht Poids net	Dimensioni imballo Shipping Verpack. abmessungen Dim. emballage	Peso lordo Gross weight Bruttogewicht Poids brut
	watt/Hp		r.p.m.	mm	mm	mm	mm	mm	mm	mm	Kg	mm	kg
GFX Hp 1.5	1100/1,5	230-400V/50Hz	1400	140x80	202	395	310	448	412	610	25	600x500x420	28
GFX Hp 2	1500/2	230-400V/50Hz	1400	190x95	228	475	330	528	518	730	35	800x600x520	38
GF Hp 4	3000/4	230-400V/50Hz	1400	300x160	340	700	640	750	640	1100	63	870x840x740	80

Potencia
Potência
 Мощность

Alimentación
Alimentação
Электропитание
電源

Giros rodillo
Giros cilindro
Обороты валика
滾筒轉速

Dimensiones boca
Dimensões boca
Размеры отверстия
開口尺寸

A B C D E F

Peso neto
Peso líquido
Вес нетто
淨重

Dimensiones embalaje
Dimensões embalagem
Размеры упаковки
包裝尺寸

Peso bruto
Peso bruto
Вес брутто
毛重



GFX HP 1.5

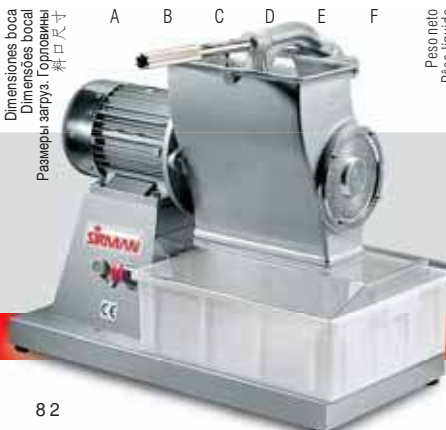

GF HP 4

TCG 12E-22E



tritacarne - grattugia meat grinder grater

- Combinato tradizionale per ristoranti e pizzerie.
- Costruzione in alluminio pressofuso lucidato.
- Motore ventilato.
- Rullo grattugia in acciaio trattato per uso alimentare.
- Riduttore tritacarne a bagno d'olio.
- Bocca ed elica tritacarne in ghisa trattata per uso alimentare, su richiesta anche in acciaio inox Aisi 304.
- Piastra e coltello inox.
- Inversione di marcia opzionale.
- **Versione CE con:**
Microinterruttore di sicurezza su leva grattugia.
Comandi IP54 con NVR.

Opzioni:

- Rullo inox per grattugia.
- Comandi con inversione.

- *Combi machine for grating and mincing.*
- *Made from diecasted polished aluminium.*
- *Ventilated motor.*
- *Galvanized steel drum.*
- *Oil-bath gear box.*
- *Cast iron head and feeding worm.*
(Aisi 304 Stainless steel on demand).
- *S/S plates and knives.*
- *Reverse (optional).*
- **CE version:**
Safety microswitch on the lever.
24 volt controls and NVR device.

Optional:

- *S/S drum.*
- *Reverse.*

TCG 12E - 22E



1. Griglia di protezione/Rullo inox di serie
Protection grate/Standard stainless steel drum



2. Opzionale: Pulsantiera con inversione di marcia
Optional: Push-button panel with reverse



3. Microinterruttore su grattugia
Microwitch on the grater

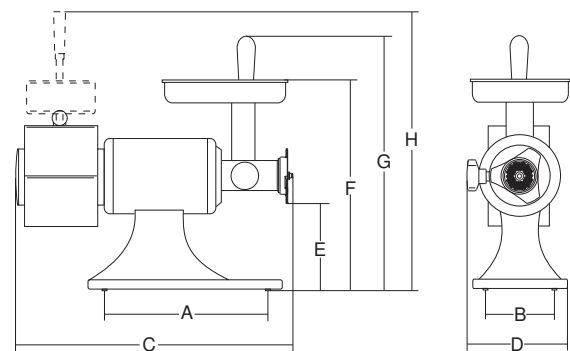

	Potenza Power Spannung Puissance	Alimentazione Power source Betriebsspannung Alimentation	Prod. oraria TC TC Output/h. TC Leistung/h. TC Débit/h.	Piastra in dotazione Standard Plate Scheibe Filtres	A	B	C	D	E	F	G	H	Peso netto Net weight Nettogewicht Poids net	Dimensioni imballo Shipping Verpack. abmessungen Dim. emballage	Peso lordo Gross weight Bruttogewicht Poids brut
	watt/Hp		Kg/10 min.	ø mm	mm	mm	mm	mm	mm	mm	mm	mm	Kg	mm	kg
TCG 12E	735-1	230-400V/50Hz	25	4,5	265	190	600	300	155	455	530	570	23	340x620x420	25
TCG 22E	800-1.2	230-400V/50Hz	33	4,5	265	190	620	300	145	455	530	570	25	340x620x420	27

Potencia
Potência
Мощность
功率

Alimentação
Alimentation
Электропитание
电源

Producción/h. TC
TC produção/h.
TC Leistung/h.
TC产量/小时

Piaça en dotación
Lâmina em dotação
Решётка
标配刀盘

A

B

C

D

E

F

G

H

Peso netto
Peso líquido
Без нетто
净重

Dimensiones embalaje
Dimensões embalagem
Размеры упаковки
包装尺寸

Peso bruto
Peso brutto
Без брутто
毛重



TCG 8 VEGAS - TCG 12 DENVER



tritacarne - grattugia meat grinder grater

- Robusta struttura in alluminio anodizzato.
- Motore ventilato.
- Riduttore tritacarne ermetico con ingranaggi a bagno d'olio.
- Ingranaggi elicoidali temperati e rettificati.
- Bocca ed elica tritacarne in lega di alluminio alimentare brillantata.
- TCG 12 Denver: bocca ed elica tritacarne inox opzionali.
- Piastra e coltello inox.
- Bocca grattugia smontabile in lega di alluminio lucidata e anodizzata.
- Rullo grattugia inox.
- Pratico cassetto per piastra e coltello.
- Inversione di marcia serie.

Versione CE con:

- Microinterruttori di sicurezza su vaschetta raccolta formaggio e leva.
- Comandi IP54 con NVR.

- *Reliable anodized aluminium construction.*
- *Ventilated motor*
- *Sealed oil-bath gear box.*
- *Ground tempered helical gears.*
- *Bright finished mouth and feeding worm.*
- *TCG 12 Denver: optional s/steel mouth and feeding worm.*
- *Stainless steel plates and knives.*
- *Demountable anodized aluminium grating mouth.*
- *S/S drum.*
- *Compartment for knives and plates.*
- *Standard reverse.*

CE version:

- *Safety microswitches on lever and receiving tray.*
- *IP54 protection rated controls and NVR device.*



TCG 12 DENVER

TCG 8 VEGAS



TCG 12 Denver

1. Passapomodoro opzionale
Optional tomato sauce making

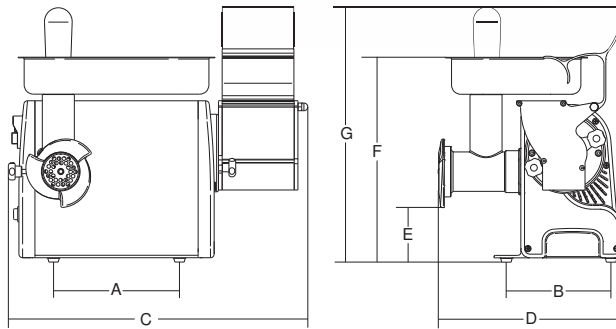

	Potenza Power Spannung Puissance	Alimentazione Power source Betriebsspannung Alimentation	Prod. oraria TC TC Output/h. TC Leistung/h. TC Débit/h.	Piastra in dotazione Standard Plate Scheibe Platines	A	B	C	D	E	F	G	Peso netto Net weight Nettogewicht Poids net	Dimensioni imballo Shipping Verpack. abmessungen Dim. emballage	Peso lordo Gross weight Bruttogewicht Poids brut
	watt/Hp		Kg/h.	ø mm	mm	mm	mm	mm	mm	mm	mm	Kg	mm	kg
TCG 8 Vegas	250/0,34	230V/50Hz	70	6	205	170	486	300	85	360	420	14	600x400x350	16
TCG 12 Denver	550/0,75	230V/50Hz	85	6	275	190	520	366	100	374	452	21,5	590x410x390	25
	Potencia Potência Мощность 功率	Alimentación Alimentação Электропитание 電源	Producción/h. TC TC produção/h. TC Leistung/h. TC 产量/小时	Piaça en dotación Lâmina em dotação 配套刀盘	A	B	C	D	E	F	G	Peso netto Peso líquido Вес нетто 净重	Dimensiones embalaje Dimensões embalagem Размеры упаковки 包装尺寸	Peso bruto Peso bruto Вес брутто 毛重



2. Cassetto porta coltello e piastra
Compartment for knives and blades



TCG 12-22 DAKOTA

triticarne - grattugia
meat grinder grater

TCG 12 DAKOTA

- Corpo in alluminio anodizzato e fianchi in ABS antiurto.
 - Generoso motore ventilato.
 - Sistema di riduzione ad ingranaggi a bagno d'olio.
 - Ingranaggi elicoidali temperati e rettificati.
 - Bocca tritacarne e bocca grattugia facilmente rimovibili senza attrezzi.
 - Bocca tritacarne in acciaio inox AISI 304 (o alluminio su mod. 22).
 - Piastra e coltello inox.
 - Bocca grattugia in alluminio brillantato di grande capienza.
 - Capiente e pratica vasca di raccolta prodotto in plexiglass trasparente.
 - Rullo smontabile in acciaio inox.
 - Comandi con inversione di marcia di serie.
- Versione CE con:**
- Comandi 24 volt con NVR.
 - Dispositivo di sicurezza su vaschetta raccolta formaggio.
 - Dispositivo di sicurezza sul pressore grattugia.

- Anodized aluminium body and ABS shockproof sides.
- Ventilated motor.
- Oil-bath gear box.
- Ground tempered helical gears.
- Removable grating/mincing mouth (no tools required).
- AISI 304 stainless steel or aluminium (only for 22 model) mincing mouth.
- S/S plates and knives.
- Large bright finished aluminium grating mouth.
- Large see-through plexiglass receiving tray.
- Demountable S/S drum.
- Standard reverse.

- CE version:**
- 24 volt controls and NVR device.
 - Safety microswitch on the receiving tray.
 - Safety microswitch on the lever.

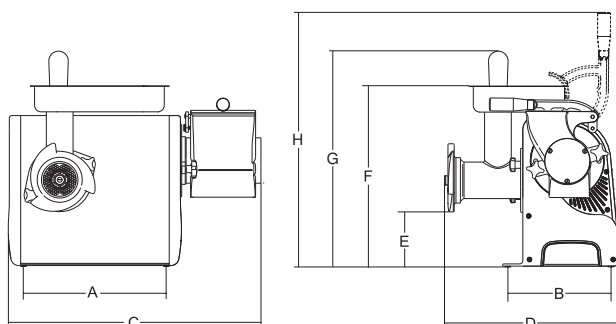

	Potenza Power Spannung Puissance	Alimentazione Power source Betriebsspannung Alimentation	Prod. oraria TC TC Output/h. TC Leistung/h. TC Débit/h.	Piastra in doiazione Standard Plate Scheibe Filères	A	B	C	D	E	F	G	H	Peso netto Net weight Nettogewicht Poids net	Dimensioni imballo Shipping Verpack. abmessungen Dim. emballage	Peso lordo Gross weight Bruttogewicht Poids brut
	watt/HP		Kg/h.	ø mm	mm	mm	mm	mm	mm	mm	mm	mm	Kg	mm	kg
TCG 12 Dakota	1ph 750 / 1 3ph 1100 / 1,5	230-400V/50Hz	95	4,5	310	225	560	360	130	415	495	575	29	630x430x450	33
TCG 22 Dakota	1ph 750 / 1 3ph 1100 / 1,5	230-400V/50Hz	120	4,5	310	225	560	360	115	415	495	575	31	630x430x450	35

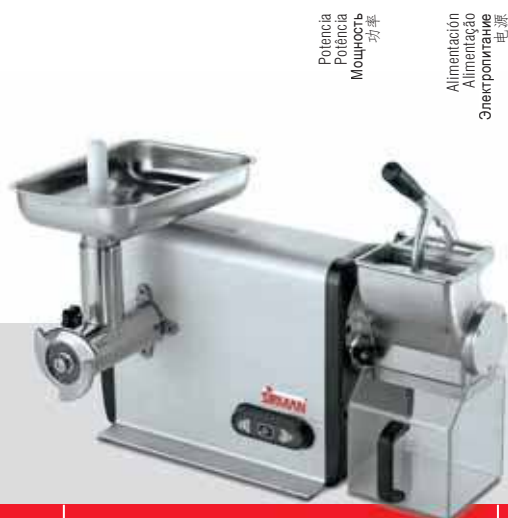

TCG 12 DAKOTA





TC 12E-22E



tritacarne meat grinders



TC 12E - 22E

- Costruzione in alluminio pressofuso lucidato.
- Motore ventilato.
- Riduttore tritacarne a bagno d'olio.
- Bocca ed elica tritacarne in ghisa trattata per uso alimentare, su richiesta anche in acciaio inox Aisi 304.
- Piastra e coltello inox.

Versione CE con:

- Comandi IP54 con NVR.
- Opzioni:
- Comandi con inversione.

- Made from diecasted polished aluminium.
- Ventilated motor.
- Oil-bath gear box
- Cast iron head and feeding worm.
(Aisi 304 stainless steel on demand).
- S/S plates and knives.

CE version:

- 24 volt controls and NVR device
- Optional:
- Reverse



1. Passapomodoro per TC/TCG 12E
Tomato sauce making for TC/TCG 12E



2. Passapomodoro per TC/TCG 22E
Tomato sauce making for TC/TCG 22E

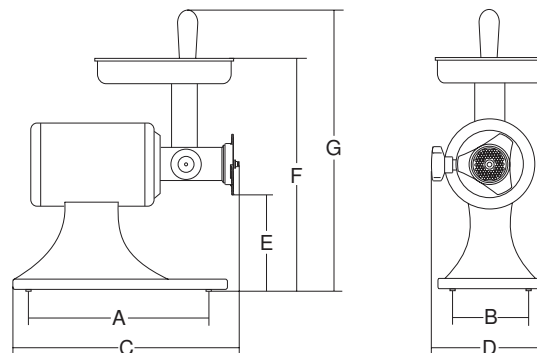

	Potenza Power Spamung Puissance	Alimentazione Power source Betriebspannung Alimentation	Prod. oraria Output/h. Leistung/h. Débit/h.	Piastra in dotazione Standard Plate Scheibe Filieres	A	B	C	D	E	F	G	Peso netto Net weight Nettogewicht Poids net	Dimensioni imballo Shipping Verpack. abmessungen Dim. emballage	Peso lordo Gross weight Bruttogewicht Poids brut
	watt/Hp		Kg/10 min.	ø mm	mm	mm	mm	mm	mm	mm	mm	Kg	mm	kg
TC 12E	735/1	230-400V/50Hz	25	4,5	225	185	430	215	140	445	520	18	320x460x470	20
TC 22E	800/1,2	230-400V/50Hz	33	4,5	225	185	440	215	135	445	520	21	320x460x470	23
	Potencia Potência Мощность 功率	Alimentación Alimentação Электронпряжение 电源	Producción/h. TC produção/h. Часовая производительность TC 产量/小时	Placa en dotación Lâmina em dotação Резервка 标配刀盘	A	B	C	D	E	F	G	Peso netto Peso líquido Вес нетто 净重	Dimensiones embalaje Dimensões embalagem Размеры упаковки 包装尺寸	Peso bruto Peso bruto Вес брутто 毛重



TC 8 VEGAS - TC 12 DENVER



tritacarne meat grinder

- Robusta struttura in alluminio anodizzato.
- Motore ventilato.
- Riduttore tritacarne ermetico con ingranaggi a bagno d'olio.
- Ingranaggi elicoidali temperati e rettificati.
- Bocca ed elica tritacarne in lega di alluminio alimentare brillantata.
- TC 12 Denver: bocca ed elica tritacarne inox opzionali.
- Piastra e coltello inox.
- Pratico cassetto per piastra e coltello.
- Inversione di marcia di serie.

Versione CE con:

- Comandi IP54 con NVR.

- Anodized aluminium body and ABS shockproof sides.
- Ventilated motor.
- Oil-bath gear box.
- Ground tempered helical gears.
- Bright finished mouth and feeding worm.
- TC 12 Denver: optional s/steel mouth and feeding worm.
- S/S plates and knives.
- Compartment for knives and plates.
- Standard reverse.

CE version:

- IP 54 protection rated controls and NVR device.



TC 8 VEGAS



TC 12 DENVER



TC 12 Denver

1. Passapomodoro opzionale
Optional tomato sauce making

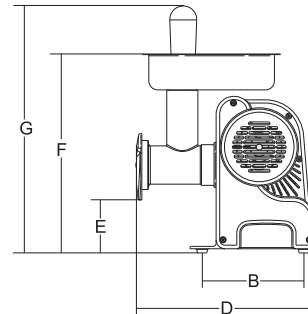
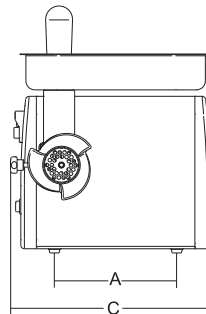

	Potenza Power Spannung Puissance	Alimentazione Power source Betriebsspannung Alimentation	Prod. oraria TC TC Output/h. TC Leistung/h. TC Débit/h.	Piastra in dotazione Standard Plate Scheibe Filtres	A	B	C	D	E	F	G	Peso netto Net weight Nettogewicht Poids net	Dimensioni imballo Shipping Verpack, abmessungen Dim. emballage	Peso lordo Gross weight Bruttogewicht Poids brut
	watt/Hp		Kg/h.	ø mm	mm	mm	mm	mm	mm	mm	mm	Kg	mm	kg
TC 8 Vegas	250/0,34	230V/50Hz	70	6	205	170	335	300	85	360	410	10	560x400x350	12
TC 12 Denver	550/0,75	230-400V/50Hz	85	6	275	190	377	366	100	375	452	19	590x410x390	22,5

Potencia
Potência
Мощность

Alimentación
Alimentação
Электропитание
电源

Producción/h.
TC producción/h.
TC产量/小时
Часовая производительность TC

Plaça en dotación
Lamina en dotação
Фильтр
筛网/刀盘

A B C D E F G

Peso neto
Peso líquido
Вес нетто
净重

Dimensiones embalaje
Dimensões embalagem
Размеры упаковки
包装尺寸

Peso bruto
Peso bruto
Вес брутто
毛重



2. Cassetto porta coltello e piastra
Compartment for knives and blades





TC 12-22 DAKOTA

tritacarne meat grinders



TC 22 DAKOTA

- Facilmente trasportabile grazie alle pratiche maniglie.
- Corpo in alluminio anodizzato e fianchi in ABS antiurto.
- Generoso motore ventilato.
- Sistema di riduzione ad ingranaggi a bagno d'olio.
- Ingranaggi elicoidali temperati e rettificati.
- Bocca tritacarne in acciaio inox AISI 304 (o alluminio su mod. 22).
- Piastra e coltello inox.
- Comandi con inversione di marcia di serie.

Versione CE con:

- Comandi 24 volt con NVR.

- *Easy to carry thanks to its sides handles.*
- *Anodized aluminium body and ABS shockproof sides.*
- *Ventilated motor.*
- *Oil-bath gear box.*
- *Ground tempered helical gears.*
- *Easy to remove AISI 304 S/S or aluminium (only for 22 model) mincing mouth.*
- *S/S plates and knives.*
- *Standard reverse.*

CE version:

- *24 volt controls and NVR device.*

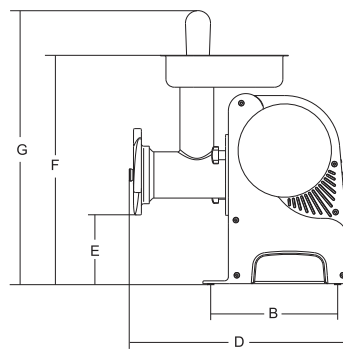
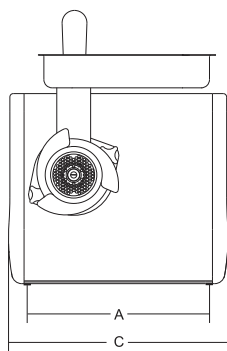

	Potenza Power Spannung Puissance	Alimentazione Power source Betriebsspannung Alimentation	Prod. oraria TC TC Output/h. TC Leistung/h. TC Débit/h.	Piastra in dotazione Standard Plate Schleibe Filières	A	B	C	D	E	F	G	Peso netto Net weight Nettogewicht Poids net	Dimensioni imballo Shipping Verpack. abmessungen Dim. emballage	Peso lordo Gross weight Bruttogewicht Poids brut
	watt/Hp		Kg/h.	ø mm	mm	mm	mm	mm	mm	mm	mm	Kg	mm	kg
TC 12 Dakota	1ph 750 / 1 3ph 1100/ 1,5	230-400V/50Hz	95	4,5	310	225	395	360	130	415	485	24	570x750x800	34
TC 22 Dakota	1ph 750 / 1 3ph 1100/ 1,5	230-400V/50Hz	120	4,5	310	225	395	360	115	415	485	26	570x750x800	36

	Potencia Potência Мощность 功率	Alimentación Alimentação Электропитание 电源	Producción/h. TC TC produção/h. TC Leistung/h. TC产量/小时	Piaça en dotación Lâmina em dotação Пластина 标配刀盘	A	B	C	D	E	F	G	Peso netto Peso líquido Вес нетто 净重	Dimensiones embalaje Dimensões embalagem Размеры упаковки 包装尺寸	Peso bruto Peso bruto Вес брутто 毛重



TC 12 DAKOTA

1. Passapomodoro per TC12 opzionale
Optional tomato sauce making for TC12



TC 12 DAKOTA



DOLOMITI

abbattitori blast chillers

- Studiati per grandi prestazioni e facile utilizzo.
- Dolomiti 3 P e Dolomiti 5 P: struttura esterna in lamiera plastificata ed interna in acciaio inox
- Dolomiti 5-10-14 Gelateria: struttura esterna ed interna in acciaio inox.
- Capaci di contenere sia gastronorm 1/1 che teglie pasticceria 60x40 cm (no Dolomiti 3 2/3).
- Distanza tra ripiani regolabile.
- Abbattimento positivo, negativo, hard e mantenimento.
- Sistema di ventilazione diffuso che evita di rovinare il prodotto.
- Gas R404A.
- Guarnizione porta riscaldata per evitarne il bloccaggio.
- Portata max garantita di Kg 150 per tutte le versioni da pavimento con top.
- Disponibili senza top per il posizionamento sotto banchi/tavoli da lavoro.
- Porte reversibili di serie per tutti i modelli da pavimento.

- *Designed for high efficiency and ease of use.*
- *Dolomiti 3 P and Dolomiti 5 P: made from laminated metal outer structure and stainless steel inner structure.*
- *Dolomiti 5-10-14 Gelateria: made from stainless steel.*
- *It can accept both 1/1 gastronorm trays or 60x40 cm trays (not on Dolomiti 3 2/3).*
- *Distance between shelves adjustable*
- *Blast freezing, chilling, hard programs and hold function.*
- *Diffused ventilation prevents product damage*
- *R404A Gas.*
- *Heated door gasket avoids door's clogging.*
- *Guaranteed maximum load kg 150 on all the floor models with top*
- *Without top for under counter installation*
- *Reversible doors on all floor models.*



DOLOMITI 3 - 2/3 P



DOLOMITI 3 - 1/1 P



DOLOMITI 5 / DOLOMITI 5 P

DOLOMITI 5 - 1/1 / DOLOMITI 5 - 1/1 P



1. Comandi base
Basic controls



2. Comandi Gelateria
Gelateria controls



3. Sonda rilevamento temperatura
Probe to survey the core
temperature of the product



4. Distanza ripiani mm 50 regolabile
Distance between shelves
adjustable mm 50

Comandi Base:

- abbattimento positivo/negativo/hard e mantenimento.
- facile ed intuitivo sia a tempo che a sonda
- ciclo di sbrinamento.

Comandi Gelateria:

- abbattimento positivo/negativo/hard e mantenimento.
- ciclo di sbrinamento.
- con programmi.
- predisposizione per la sonda riscaldata (opzionale).

Basic controls:

- Blast freezing/chilling, hard and hold program.
- Time and probe easy and intuitive use.
- Defrosting program.

Gelateria controls:

- Blast freezing/chilling, hard and hold program.
- Programmable.
- Equipped with optional heated probe.



5. Porte reversibili di serie per Dolomiti 5, 10 e 14
Standard reversible doors on Dolomiti 5, 10 and 14



6. DOLOMITI 5
Disponibili senza top per il posizionamento sotto il banco/tavolo da lavoro
Without top for under counter installation



DOLOMITI 5 GELATERIA



DOLOMITI 7 GELATERIA



DOLOMITI 10 GELATERIA



DOLOMITI 14 GELATERIA



DOLOMITI 3 - 2/3 P



DOLOMITI 3 - 1/1 P



DOLOMITI 5



DOLOMITI 5 GELATERIA



DOLOMITI 7 GELATERIA



DOLOMITI 10 GELATERIA

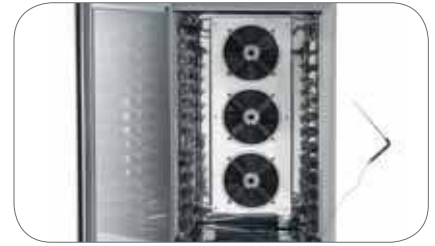

DOLOMITI 14 GELATERIA



DOLOMITI GELATERIA

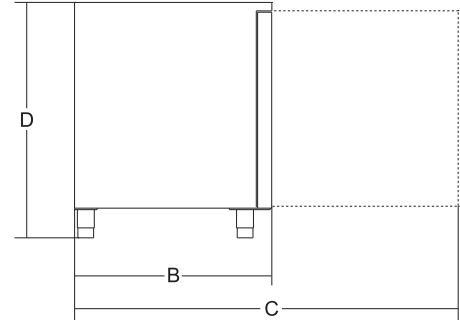
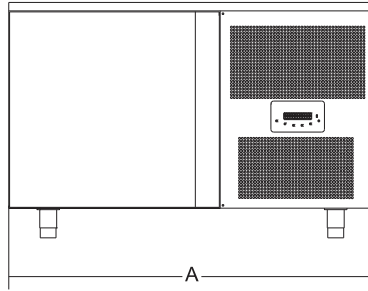

	Alimentazione Power source Betriebsspannung Alimentation	Potenza assorbita Absorbed power Aufgenommene Leistung Puissance absorbée	Res. abb. temp. Chilling efficiency Kühlleistung Rendém. refroidiss. rap.	Res. surgelazione Freezing efficiency Gefrierleistung Rendement surgelation	Volume Volume Volumen Volume	Numero teglie Number of trays Anzahl bleche Nombre de bacs	Dimensioni interne Inner dimensions Gebrauchmaassungen Dimensions intérieures	A	B	C	D	Peso netto Net weight Nettogewicht Poids net	Dimensioni imballo Shipping Verpack. abmessungen Dim. emballage	Peso lordo Gross weight Bruttogewicht Poids brut
	watt				lit	n.	mm	mm	mm	mm	mm	Kg	mm	kg
Dolomiti 3 P - 2/3	230V/50Hz	680	+70/+3°C 90 min. Kg 8	+70/-20°C 240 min. Kg 5	29	3 - 2/3 gastronom	340x340 h. 270	640	630	1220	400	45	660x650 x550	50
Dolomiti 3 P - 1/1	230V/50Hz	758	+70/+3°C 90 min. Kg 9	+70/-20°C 240 min. Kg 6	36	3 - 1/1 gastronom	340x550 h. 370	640	740	1220	500	60	660x760 x650	68
Dolomiti 5 / P - 1/1	230V/50Hz	1116	+70/+3°C 90 min. Kg 10	+70/-20°C 240 min. Kg 7	70	5 - 1/1 gastronom	560x470 h. 330	680	680	1295	880	85	700x750 x1050	95
Dolomiti 5 / P	230V/50Hz	1200	+70/+3°C 90 min. Kg 12	+70/-20°C 240 min. Kg 9	95	5 - 1/1 gastronom	5 - 60x40	750	750	1435	880	95	770x820 x1050	105
Dolomiti 5 Gelateria	230V/50Hz	1385	+70/+3°C 90 min. Kg 12	+70/-20°C 240 min. Kg 9	95	5 - 1/1 gastronom	5 - 60x40 h. 330	750	750	1435	850	98	770x820 x1020	108
Dolomiti 7 Gelateria	230V/50Hz	1493	+70/+3°C 90 min. Kg 20	+70/-18°C 240 min. Kg 12	150	7 - 1/1 gastronom	630x420 h. 600	1300	700	1435	830	155	1320x720 x1000	165
Dolomiti 10 Gelateria	400V/50Hz 3F+N	1775	+70/+3°C 90 min. Kg 25	+70/-18°C 240 min. Kg 15	206	10 - 1/1 gastronom	630x430 h. 760	750	750	1435	1500	185	770x820 x1670	200
Dolomiti 14 Gelateria	400V/50Hz 3F+N	3400	+70/+3°C 90 min. Kg 40	+70/-18°C 240 min. Kg 25	282	14 - 1/1 gastronom	630x430 h. 1040	750	750	1435	1900	265	770x820 x2070	280
	Alimentación Alimentação Электроснабжение 電源	Potencia absorbida Potência absorvida Потребляемая мощность 需索功率	Rendimiento abs. temp. Rend. Resfriamento rap. Эффект охлаждения 冷藏功效	Rendimiento congelación Rend. congelamento Эффект замораживания 冷冻功效	Volumen Volume Объем 体积	Numero de fuentes Número fontes кол-во gastronормей 托盘数量	Dimensiones internas Dimensões internas Внутренние размеры 内部尺寸	A	B	C	D	Peso neto Peso líquido Вес нетто 净重	Dimensiones embalaje Dimensões embalagem Размеры упаковки 包装尺寸	Peso bruto Peso bruto Вес брутто 毛重



MCF - MPF

macinacaffè - macinapepe coffee and pepper grinders



- Sobria e robusta struttura in acciaio verniciato a polveri.
- Macine in acciaio speciale K100.
- Millimetrico sistema di regolazione della macinatura.
- Campane in lexan trasparente con bocchettone di chiusura.
- Ferma sacchetti di serie su tutti i modelli.
- Motori ventilati per uso continuo.
- Ideali per caffè, pepe e altre piccole spezie.

- Strong and sober varnished steel body.
- Grinders made from special steel K100.
- Grinding system with millimetric precision.
- See-through lexan container with locking device.
- Bag holder (standard for all versions).
- Ventilated motor for continuous operation.
- Perfect for coffee, pepper and small spice.

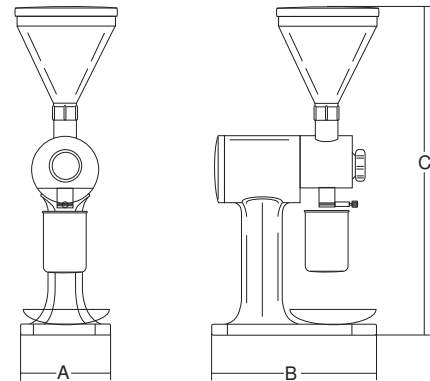

	Potenza Power Spannung Puissance	Alimentazione Power source Betriebsspannung Alimentation	Capacità Capacity Kapazität Capacité	Ø Macine Ø Grinders Ø Møhlen Ø Meules	Altezza max sacchetto Max bag high Säckelhöhe Hauter enveloppe	Prod. oraria Output/h. Leistung/h Débit/h	A	B	C	Peso netto Net weight Nettogewicht Poids net	Dimensioni imballo Shipping Verpack. abmessungen Dim. emballage	Peso lordo Gross weight Bruttogewicht Poids brut
	watt/Hp		lt	mm	mm	Kg/h.	mm	mm	mm	Kg	mm	kg
MCF-MPF 3	2208/3	230-400/50Hz	3	107	360	90-180	320	480	820	34	310x730x1140	37

Potencia
Potência
Мощность
功率

Alimentación
Alimentação
Электропитание
电源

Capacidad
Capacidade
Вместимость
容積

Ø Molinos
Ø Moedores
Ø жерновов
磨肉孔径

Altura máx. bolsa
Altura máx. saco
Макс. высота пакета
袋子最大高度

Producción/h.
Produção/h.
Производительность
产量/小时

A B C

Peso neto
Peso líquido
Вес нетто
淨重

Dimensiones embalaje
Dimensões embalagem
Размеры упаковки
包裝尺寸

Peso bruto
Peso bruto
Вес брутто
毛重



MPF



MCF

LAVORAZIONE CARNE | MEAT PROCESSING MACHINES

Per venire incontro alle esigenze di un ampio ed importante settore del mercato - quale quello rivolto alla lavorazione della carne a tutti i livelli - Sirman propone un'ampia e diversificata scelta di strumenti per gli addetti ai lavori quali tritacarne, segaossa, insaccatrici, impastatrici e altre utili attrezzature.

Affidabilità, performance e resistenza agli ambienti più impegnativi, sono diventate le linee guida per lo sviluppo di sempre nuovi prodotti e soluzioni in questo settore. L'attenzione alla facile pulizia e sanificazione, grazie alla smontabilità dei particolari più critici, e la facile manutenibilità, sono oramai diventati caratteri distintivi di questa linea di prodotti, riconosciuti dal mercato italiano e internazionale.

To fulfill the needs of an important as well as complex business such as the meat processing industry at all levels, Sirman offers a wide and diversified array of products such as mincers, mixer-grinders, saws, fillers and mixer kneaders.

Dependability, performance and durability into the harshest environments are the guidelines for the development of new products and solutions.

Furthermore, the ease of maintenance, cleaning and sanitation due to the fast breakdown of the critical parts are distinguishing features of Sirman meat processing machines, nationally and internationally recognized.





TC 22-32 COLORADO

tritacarne meat grinders



- Corpo macchina totalmente in acciaio inox AISI 304.
- Potenti motori IP 55 autoventilati per uso continuo.
- Riduttore a bagno d'olio con ingranaggi rettificati.
- Riduttore con doppio sistema di protezione dai liquidi.
- Rapido fissaggio bocca senza utensili.
- Gruppo macinazione completamente in acciaio inox facilmente e totalmente smontabile per pulizia.
- Tramoggia rimovibile interbloccata (32 CE).
- Comandi 24 Volt IP 54 con inversione (CE).

Opzioni:

- Sistema di protezione interbloccato per uso piastre con foro > 8 mm.
- Bocche Unger parziale o totale.
- Comandi inox IP 67.



TC 32 COLORADO



- AISI 304 stainless steel construction.
- Powerful IP 55 insulated and fan-cooled motors for continuous use.
- Endless screw motor-reducer running in an oil-bath enables a long service life.
- Motor-reducer equipped with a double seal for long, trouble-free service.
- Convenient, no-tools head lock mechanism.
- Stainless steel mincing head carefully designed for high yield production, completely removable for easy of cleaning.
- Feed tray provided with safety interlock (no. 32 CE versions).
- IP 54 protected, 24 V controls.

Optional:

- Interlock protection for more than 8 mm holes plates (An interlock protection system is required in order to utilize more than 8 mm holes plates).
- Partial or total Unger system mincing head.
- Stainless steel IP 67 protected controls.

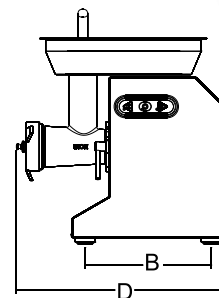
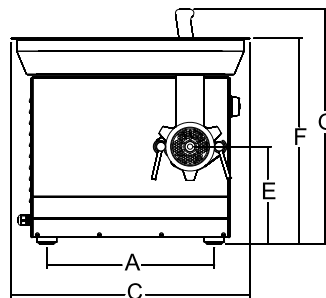

	Potenza Power Spannung Puissance	Alimentazione Power source Betriebsspannung Alimentation	Prod. oraria TC TC Output/h. TC Leistung/h. TC Débit/h.	Placina in dotazione Standard Plate Scheibe Platines	A	B	C	D	E	F	G	Peso netto Net weight Nettogewicht Poids net	Dimensioni imballo Shipping Verpack, abmessungen Dim. emballage	Peso lordo Gross weight Bruttogewicht Poids brut
	watt/Hp		Kg/h.	ø mm	mm	mm	mm	mm	mm	mm	mm	Kg	mm	kg
TC 22 Colorado	1470/2	230-400V/50Hz	300	4,5	350	264	500	437	205	432	490	32	600x500x500	35
TC 32 Colorado	2205/3	230-400V/50Hz	400	4,5	400	264	610	465	190	427	530	39	720x570x770	61

Potencia
Potência
Мощность
功率

Alimentación
Alimentação
Электропитание
電源

Producción/h. TC
TC produção/h.
Производство
TC产量/小时
Placa en dotación
Lamina em dotação
Platines
标配刀盘

A B C D E F G

Peso netto
Peso líquido
Bec netto
净重

Dimensiones embalaje
Dimensões embalagem
Размеры упаковки
包装尺寸

Peso bruto
Peso bruto
Bec brutto
毛重



TC 22 COLORADO

1. Format M. opzionale
Optional Format M



TC 22 COLORADO CON HAMBURGATRICHE





TC 32 CALIFORNIA

tritacarne meat grinders



- Tritacarne solido, robusto e performante adatto a piccoli laboratori, collettività, mense e grandi cucine.
- Dotato di gambe e ruote in acciaio inox con freno per una sicura stabilità e grande praticità
- Maneggevole, comodo e compatto lo rendono adatto ad ogni tipologia di spazio
- Corpo macchina totalmente in acciaio inox AISI 304.
- Grande tramoggia di carico cm 410x610x76 mm con micro per una maggior sicurezza
- Potenti motori IP 55 autoventilati per uso continuo.
- Riduttore a bagno d'olio con ingranaggi rettificati.
- Riduttore con doppio sistema di protezione dai liquidi.
- Rapido fissaggio bocca senza utensili.
- Gruppo macinazione completamente in acciaio inox facilmente e totalmente smontabile per pulizia.
- Tramoggia rimovibile interbloccata (CE).
- Comandi inox, 24 Volt IP67.

Opzioni:

- Sistema di protezione interbloccato per uso piastre con foro > 8 mm.
- Bocche Unger parziale o totale.

- Heavy-duty meat grinder with high capacity, suitable for all kitchens;
- The machine is on stand with stainless steel casters and therefore very stable and easy to move;
- AISI 304 stainless steel construction;
- large 410x610x76 mm feeding tray with safety microswitch;
- Powerful IP55 insulated and cooled motors for continuous use;
- Endless screw motor-reducer an oil-bath enables a long service life .
- Reducer equipped with a double seal for long, trouble-free service.
- Head can be locked in with no tools.
- Stainless steel head with high output capacity, completely removable for cleaning.
- Feed tray provided with safety interlock CE versions.
- Stainless steel IP 67 protected, 24 V controls.

Optional:

- Interlock protection for more than 8 mm holes plates (An interlock protection system is required in order to utilize more than 8 mm holes plates).
- Partial or total Unger mincing head.

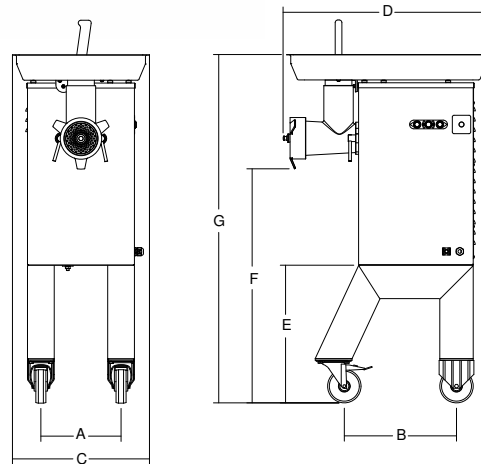

Standard enterprise 1/2 Unger Unger Totale

	Potenza Power Spannung Puissance	Alimentazione Power source Betriebsspannung Alimentation	Prod. oraria TC TC Output/h. TC Leistung/h. TC Débit/h.	Placina indolazione Standard Plate Scheibe Filieres	A	B	C	D	E	F	G	Peso netto Net weight Nettogewicht Poids net	Dimensioni imballo Shipping Verpack. abmessungen Dim. emballage	Peso lordo Gross weight Bruttogewicht Poids brut
	watt/Hp		Kg/h.	ø mm	mm	mm	mm	mm	mm	mm	mm	Kg	mm	kg
TC 32 California	2205/3	230-400V/50Hz	400	6	240	336	410	621	412	700	1042	55	720x570x1180	70

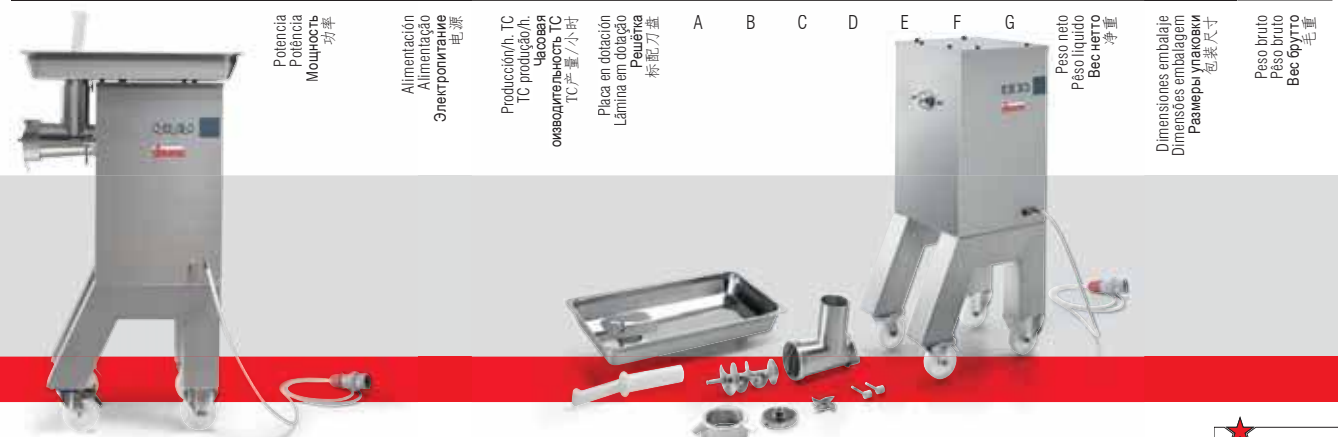



TC 22-32 BARCELLO NA

tritacarne meat grinders

- Tritacarne compatto dalle alte prestazioni.
- Comandi IP 54 in 24 Volt con inversione (versione CE).
- Riduttore ermetico a bagno d'olio.
- Riduttore protetto dai liquidi da un doppio sistema di isolamento.
- Bocca e perno trascinatore in acciaio inox Aisi 304.
- Rapido e robusto sistema di fissaggio bocca, blocco rapido bocca brevettato su TC 32.
- Versione 22 disponibile anche con collo tondo.
- Potenti motori ventilati, per uso continuo.
- Motori monofase con protezione termica.
- Pratico vano porta piastre e coltelli con coperchio.
- Estrema semplicità di pulizia.
- **Opzioni:** Bocca unger e semiunger Hamburgatrice. Insacchiatrice continua. Tramoggia gigante. Gambe medie per TC 32. Sistema di protezione interbloccato per uso piastre con foro > 8 mm.

- *Heavy duty compact mincer.*
- *IP 54 protection rate, 24 Volt controls, reverse (CE version).*
- *Sealed oil-bath gear box.*
- *Waterproof gear box with double sealing system.*
- *Aisi 304 S/S mouth and feeding worm.*
- *Quick and sturdy head locking system (patented on 32 version).*
- *22 version available also with round feeding neck.*
- *High efficiency ventilated motors for continuous operation.*
- *Thermal protection on single phase motors*
- *Compartment for knives and plates.*
- *Easy cleaning.*
- **Optional:** *Total/half unger system. Patty former. Stuffer kit. Oversize tray. Medium legs for TC 32. Interlock protection for more than 8 mm holes plates (An interlock protection system is required in order to utilize more than 8 mm holes plates).*



TC 32 BARCELLONA



1. Vano per piastre e coltelli
Compartment for knives and plates



2. Sblocco bocca TC 32/ICE
Head locking TC 32 / ICE



3. Opzione insacchiatrice
Optional stuffer kit



4. Opzione hamburgatrice
Optional patty former



TC 22 BARCELLONA



BARCELLONA 22 □

BARCELLONA 22 ○

TC 22-32 BARCELLONA ICE



tritacarne refrigerato refrigerated meat grinders



- Innovativo e supercompatto tritacarne refrigerato.
- **Sistema raffreddante con modulo termoelettrico:** Senza compressore. Senza gas. A risparmio energetico.
- Potenza modulo termoelettrico: 70 Watt
- Raffreddamento su collo e bocca.
- Termometro digitale di controllo.
- Tramoggia e collo inox rimovibili per la pulizia.
- Caratteristiche TC come modello Barcellona.
- Qualsiasi manutenzione non necessita di frigorista.
- Collo di introduzione quadro per grande produttività anche in seconda passata.
- Motori monofase con protezione termica.
- Blocco rapido bocca brevettato su 32.
- **Opzioni:** Bocca unger e semiunger. Hamburgatrice. Insacatrice continua. Tramoggia gigante. Sistema di protezione interbloccato per uso piastre con foro > 8 mm.

- *Innovative extremely compact refrigerated mincer.*
- **Thermo-electric module refrigerating system:** Without compressor. Without gas. Energy saving.
- Thermo-electric module power: 70 Watt
- Refrigerated feeding neck and grinding end.
- Self-adjusted temperature.
- Removable and easy to clean S/S tray and feeding neck.
- Same mincing features as model Barcellona.
- Easy maintenance. (no need of refrigerator technician)
- Square feeding neck. (High output also with pre-minced meat).
- Thermal protection on single phase motors.
- Quick and sturdy head locking system (patented on 32 version).
- **Option:** Half/total unger system. Patty former. Stuffer kit. Oversize tray. Medium legs for TC 32. Interlock protection for more than 8 mm holes plates. (An interlock protection system is required in order to utilize more than 8 mm holes plates).

TC 22 BARCELLONA ICE



1. Comandi TC ICE
TC ICE controls



2. Griglie di ventilazione TC ICE
TC ICE airing take



Standard o enterprise 1/2 Unger Unger Totale



3. Opzione gambe con ruote e tramoggia gigante
Optional legs with wheels and oversize tray



TC 32 BARCELLONA Q ICE

TC 32 BARCELLONA Q ICE CON HAMBURGATRICE



TC 22-32 BARCELLONA HAMBURGATRICE

hamburger press

Stampi opzionali:
Optional moulds:



Ovale / Oval
mm 115x96 h. 14 g 130



Polpette / Meatball
mm ø 40 h.14x4 g 20x4



Quadro / Square
mm 100x100 h. 14 g 150



Coscia di pollo / Leg of chicken
mm 120x92x35 h. 14 g 105



TC 32 BARCELLONA
con Hamburgatrice opzionale
with optional Hamburger press

Di serie / Standard
mm ø 110 h. 14

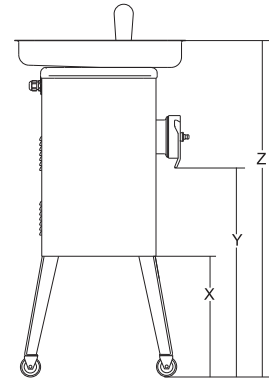
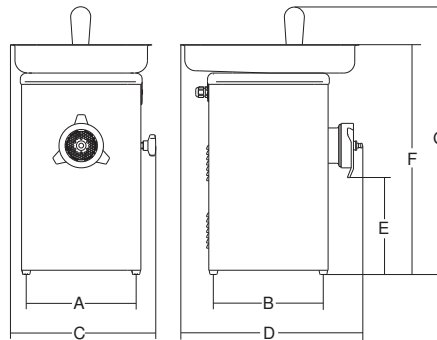

X: 435 mm
Y: 685 mm
Z: 1005 mm

	Potenza Power Spannung Puissance	Alimentazione Power source Betriebspannung Alimentation	Prod. oraria TC TC Output/h. TC Leistung/h. TC Debit/h.	Piastra in dotazione Standard Plate Scheibe Filleres	A	B	C	D	E	F	G	Peso netto Net weight Nettogewicht Poids net	Dimensioni imballo Shipping Verpack abmessungen Dim. emballage	Peso lordo Gross weight Bruttogewicht Poids brut
	watt/HP		Kg/h.	ø mm	mm	mm	mm	mm	mm	mm	mm	Kg	mm	kg
TC 22 Barcellona ○	1ph 1100/1,5 3ph 1472/2	230-400V/50Hz	300	4,5	250	185	310	350	225	540	615	31	720x570x770	41
TC 22 Barcellona □	1ph 1100/1,5 3ph 1472/2	230-400V/50Hz	350	4,5	250	185	310	350	225	540	615	31	720x570x770	41
TC 32 Barcellona □	1ph 1840/2,5 3ph 2200/3	230-400V/50Hz	500	4,5	250	320	355	500	260	580	690	44	720x570x770	54
TC 22 Barcellona ICE □	1ph 1100/1,5 3ph 1472/2	230-400V/50Hz	350	4,5	250	185	310	350	225	540	615	34	720x570x770	44
TC 32 Barcellona ICE □	1ph 1840/2,5 3ph 2200/3	230-400V/50Hz	500	4,5	250	320	355	500	260	580	690	48	720x570x770	58
	Potencia Potência Мощность 功率	Alimentación Alimentação Электропитание 電源	Producción/h. TC TC produção/h. Часовая оказовательность TC TC产量/小时	Placa en dotación Lâmina em dotação Решетка 标配刀盘	A	B	C	D	E	F	G	Peso neto Peso líquido Вес нетто 淨重	Dimensiones embalaje Dimensões embalagem Размеры упаковки 包装尺寸	Peso bruto Peso bruto Вес брутто 毛重



TC 22-32 NEVADA



tritacarne meat grinders



TC 22 NEVADA

- Corpo macchina totalmente in acciaio inox AISI 304.
- Potenti motori IP 55 autoventilati per uso continuo.
- Riduttore a bagno d'olio con ingranaggi rettificati.
- Riduttore con doppio sistema di protezione dai liquidi.
- Pratico fissaggio bocca con leva interbloccata (CE).
- Gruppo macinazione ad alta produzione completamente in acciaio inox.
- Collo introduzione quadro per prestazioni superbe in seconda passata.
- Tramoggia rimovibile interbloccata (CE) con collo fino a zona macinazione.
- Comandi inox IP 67 con inversione (CE).

Opzioni:

- Sistema di protezione interbloccato per uso piastre con foro > 8 mm.
- Bocche Unger parziale o totale.
- Coperchio plexiglass su tramoggia.
- Hamburgatrice Format M.

- AISI 304 stainless steel construction.
- Powerful IP 55 insulated and fan-cooled motors for continuous use.
- Endless screw motor-reducer running in an oil-bath enables a long service life.
- Motor-reducer equipped with a double seal for long, trouble-free service.
- Convenient head interlock mechanism (CE versions).
- Stainless steel mincing head carefully designed for high yield production.
- Feed tray designed with square neck for outstanding performance.
- Feed tray provided with safety interlock (CE versions).
- Stainless steel IP 67 protected controls.

Options:

- Interlock protection for more than 8 mm holes plates. (An interlock protection system is required in order to utilize more than 8 mm holes plates).
- Partial or total Unger system mincing head.
- Plexiglass feed tray lid.
- Patty-forming attachment FORMAT M.



1. Coperchio opzionale
Optional lid



Standard o enterprise
1/2 Unger
Unger Totale

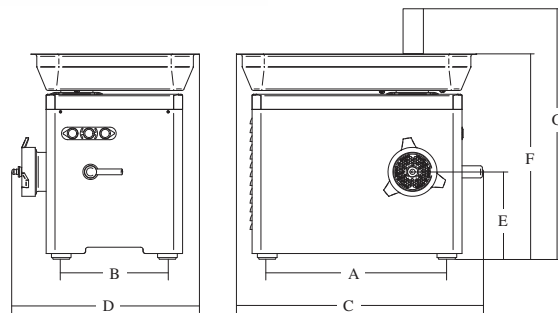

Potenza
Power
Spannung
Puissance

Alimentazione
Power source
Betriebsspannung
Alimentation

Prod. oraria TC
TC Output/h.
TC Leistung/h.
TC Débit/h.

Placina in dotazione
Standard Plate
Scheibe
Filtres

A B C D E F G

Peso netto
Net weight
Nettogewicht
Poids net

Dimensioni imballo
Shipping
Verpack-abmessungen
Dim. emballage

Peso lordo
Gross weight
Bruttogewicht
Poids brut

	watt/Hp		Kg/h.	ø mm	mm	mm	mm	mm	mm	mm	mm	mm	Kg	mm	kg
TC 22 Nevada	1ph 1100/1,5 3ph 1472/2	230-400V/50Hz	350	4,5	374	221	512	390	182	428	531	36	600x500x500	39	
TC 32 Nevada	1ph 1840/2,5 3ph 2200/3	230-400V/50Hz	500	4,5	480	285	637	455	207	447	551	50	720x570x770	72	



Potencia
Potência
Мощность

Alimentación
Alimentação
Электропитание

Producción/h.
TC producción/h.
TC产量/小时

Placina em dotação
Lamina em dotação
Решетка
标配刀盘

A B C D E F G

Peso netto
Peso líquido
Бес-нетто
净重

Dimensiones embalaje
Dimensões embalagem
Размеры упаковки
包装尺寸

Peso bruto
Peso bruto
Бес брутто
毛重



TC 22-32 NEVADA ICE

tritacarne refrigerato refrigerated meat grinders



- Caratteristiche tecniche e performance identiche a Nevada.
- Impianto refrigerante 150 Watt con gas R304.
- Refrigerazione su collo, bocca e tramoggia.
- Comandi inox IP 67 con inversione.

Opzioni:

- Sistema di protezione interbloccato per uso piastre con foro > 8 mm.
- Bocche Unger parziale o totale.
- Coperchio plexiglass su tramoggia.
- Hamburgatrice Format M.

- Featuring the very same advantages of the Nevada series, the Nevada Ice series feature:
- 150 Watt, R304 gas refrigerator.
- Refrigeration on feed tray neck, mincing head and on the whole feed tray.
- Stainless steel IP 67 protected controls with reverse.

Options:

- Interlock protection for more than 8 mm holes plates. (An interlock protection system is required in order to utilize more than 8 mm holes plates).
- Partial or total Unger system mincing head.
- Plexiglass feed tray lid.
- Patty-forming attachment Format M.



TC 32 NEVADA ICE



Standard o enterprise 1/2 Unger Unger Totale

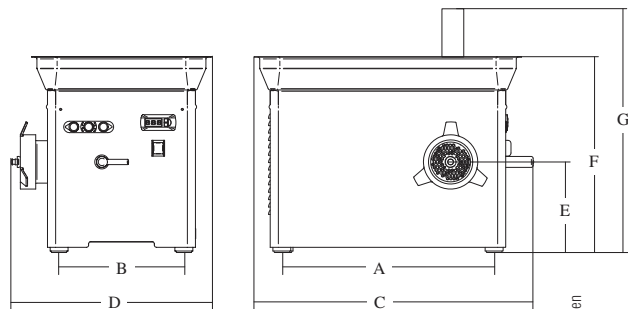

	Potenza Power Spannung Puissance	Alimentazione Power source Betriebsspannung Alimentation	Prod. oraria TC TC Output/h. TC Leistung/h. TC Débit/h.	Plastra in dotazione Standard Plate Scheibe Fillettes	A	B	C	D	E	F	G	Peso netto Net weight Nettopgewicht Poids net	Dimensioni imballo Shipping Verpack. abmessungen Dim. emballage	Peso lordo Gross weight Bruttogewicht Poids brut
	watt/HP		Kg/h.	ø mm	mm	mm	mm	mm	mm	mm	mm	Kg	mm	kg
TC 22 Nevada Ice	1ph 1100/1,5 3ph 1472/2	230-400V/50Hz	350	4,5	374	221	512	390	237	481	585	48	720x570x770	70
TC 32 Nevada Ice	1ph 1840/2,5 3ph 2200/3	230-400V/50Hz	500	4,5	480	285	637	455	207	447	551	60	720x570x770	82

Potencia
Potência
 Мощность
功率

Alimentación
Alimentação
Электропитание
电源

Producción/h. TC
TC produção/h.
 часовая производительность TC
TC产量/小时

Placa en dotación
Lamina em dotacao
Pластина
标配刀盘

A B C D E F G

Peso netto
Peso líquido
Вес-нетто
净重

Dimensiones embalaje
Dimensões embalagem
Размеры упаковки
包装尺寸

Peso bruto
Peso bruto
Вес брутто
毛重



NE
PIASTRE
IN FORO
RIORE A
DEGUATA



TC BUFFALO

tritacarne
meat grinders



TC 32 BUFFALO

Versione da tavolo
Table top version

- Grandi prestazioni in una struttura compatta.
- Bocca ad alta produzione dal disegno esclusivo.
- La grande disponibilità di accessori la rende adatta sia per l'uso nel banco che nel laboratorio.
- Bocca inox esterna con rapido fissaggio a baionetta.
- Collo introduzione quadro per grande produttività anche in seconda passata.
- Sistema di protezione ingranaggi con doppio paraolio.
- Motore ventilato per uso continuo.
- Comandi inox IP 67 con inversione.

Opzioni:

- Sistema di protezione contro i sovraccarichi di corrente.
- Tramoggia gigante e super (no TC 32 Buffalo S).
- Gambe alte medie e basse (no TC 32 Buffalo S).
- Piano portavassoio estraibile.
- Bocca unger e semiunger.
- Insacatrice continua.
- Paraspruzzi.
- Sistema di protezione interbloccato per uso piastre con foro > 8 mm.
- Predisposizione per Format S (no TC 32 Buffalo S).



TC 32 BUFFALO

Opzionale: Tramoggia gigante e Gambe
Optional legs and larger feed tray

- Compact heavy duty mincer.
- Exclusive design high output grinding head.
- Available both table top or floor standing (many optionals available).
- Stainless steel head with quick bayonette fitting.
- Square feeding neck. (High output also with pre-minced meat).
- Waterproof gear box with double sealing system.
- Ventilated motor for continuous operation.
- IP 67 protection rated controls with reverse.

Optional:

- Overload protection.
- Larger trays: "gigante" or "super" (not available for TC 32 Buffalo S).
- Short, medium, long legs (not available for TC 32 Buffalo S).
- Receiving tray holder.
- Half/total unger system.
- Stuffer kit.
- Splash guard.
- Interlock protection for more than 8 mm holes plates. (An interlock protection system is required in order to utilize more than 8 mm holes plates).
- Arrangement for Format S (not available for TC 32 Buffalo S).



TC 32 BUFFALO S

Opzionali:
Optionals:



1. Supporto vassoio
Tray support



2. Tramoggia gigante
Larger feed tray

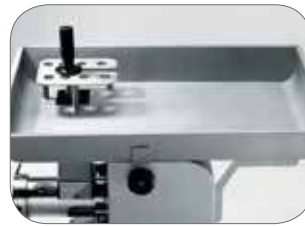

3. Tramoggia super
Lager tray "super"



4. Gambe con ruote
Legs with wheels



5. Protezione bocca per piastra
con foro $\varnothing > 8$ mm
Safety device for $\varnothing > 8$ mm plates.

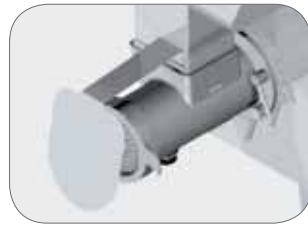

6. Paraspruzzi
Splash guard



7. Estrattore piastre
Plates removal tool



Standard 1/2 Unger Unger tot.
o enterprise

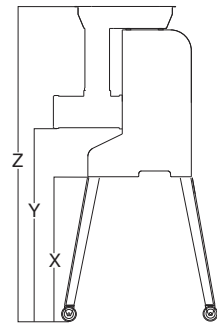
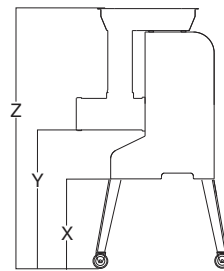
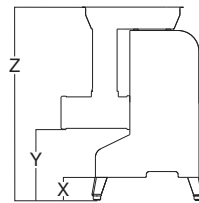
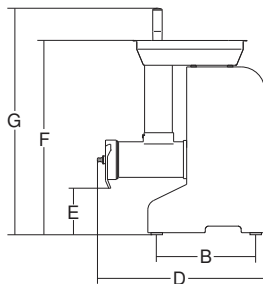
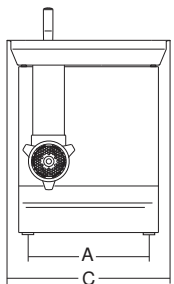

Gambe basse con piedino
Small legs with feet
X: 131 mm
Y: 271 mm
Z: 741 mm

Gambe medie con ruote
Medium legs with wheels
X: 416 mm
Y: 556 mm
Z: 1026 mm

Gambe alte con ruote
High legs with wheels
X: 688 mm
Y: 828 mm
Z: 1298 mm

	Potenza Power Spannung Puissance	Alimentazione Power source Betriebsspannung Alimentation	Prod. oraria TC TC Output/h. TC Leistung/h. TC Débit/h.	Piastra in dotazione Standard Plate Scheibe Filtères	A	B	C	D	E	F	G	Peso netto Net weight Nettogewicht Poids net	Dimensioni imballo Shipping Verpack abmessungen Dim. emballage	Peso lordo Gross weight Bruttogewicht Poids brut
	watt/Hp		Kg/H.	\varnothing mm	mm	mm	mm	mm	mm	mm	mm	Kg	mm	kg
TC 32 Buffalo Hp 3	2205/3	230-400V/50Hz	700	4,5	385	315	535	505	140	610	710	65	640x760x850	80
TC 32 Buffalo Hp 4	2940/4	400V/50Hz	700	4,5	385	315	535	505	140	610	710	65	640x760x850	80
TC 32 Buffalo S Hp 4	2940/4	400V/50Hz	700	4,5	446	320	625	538	592	592	691	70	640x760x850	85
Tramoggia standard	-	-	-	-	-	-	535x450x90	-	-	-	-	-	-	-
Tramoggia gigante	-	-	-	-	-	-	535x660x90	-	-	-	-	-	-	-
Tramoggia super	-	-	-	-	-	-	563x900x120	-	-	-	-	-	-	-

Potencia
Potência
Мощность

Alimentación
Alimentação
Электропитание

Producción/h. TC
TC produção/h.
TC产量/小时

Piaça en dotación
Lâmina em dotação
Пластина
标配刀盘

A

B

C

D

E

F

G

Peso netto
Peso líquido
Вес-нетто
净重

Dimensiones embalaje
Dimensões embalagem
Размеры упаковки
包装尺寸

Peso bruto
Peso bruto
Вес брутто
毛重



TC MONTANA

tritacarne meat grinders



- Costruzione in acciaio inox AISI 304 lavabile con spruzzo d'acqua.
- Motori trifase Hp 5 o Hp 7.
- Riduttore ermetico a bagno d'olio

Gruppo macinazione:

- Completamente in acciaio inox AISI 304
- Studiato per grandi prestazioni
- Alte prestazioni anche in seconda e successive passate
- Produzione oraria effettiva 1.100 Kg/h (42)
- Produzione oraria teorica 3500 Kg/h
- Rimanezza carne interno bocca 50-90 g
- Perno trascinatore in acciaio inox
- **Con esclusivo sistema brevettato di controllo presenza piastra e ghiera (CE)**
- Perno elica in acciaio temperato
- Veloce smontaggio gruppo macinazione per pulizia e sanificazione
- Collo introduzione quadro per maggiore velocità di carico
- Ampia tramoggia 563 x 900 h 120 mm con micro di sicurezza
- Comandi in acciaio inox IP 67 con inversione di marcia (versione CE)

Dotazione standard:

- Coltello e piastra diam. 4,5 autoaffilanti inox
- Pestello
- Attrezzo estrazione elica e piastre
- Manuale uso e manutenzione

Optional disponibili:

- Comandi FULL CONTROL per gestione accessori
- Paraspruzzi inox
- Comando a pedale
- Bocca unger parziale inox
- Bocca unger totale inox
- Bocca lunga (42)
- Sistema di protezione interbloccato per uso piastre con foro > 8 mm.
- Ampia disponibilità di piastre e coltelli specifici
- FORMAT S
- FORMAT A



TC 42 MONTANA Y12



TC 32 MONTANA Y12



Tramoggia gigante opzionale
Oversize tray optional

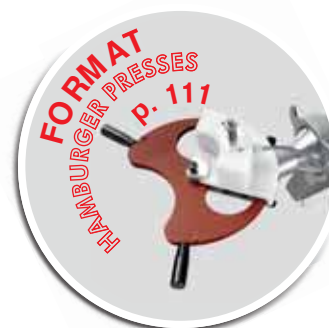

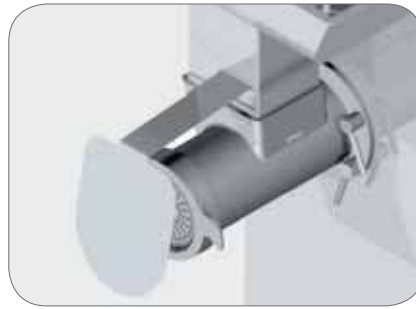

1. Opzionale: sistema di protezione interbloccato per uso piastre con foro > 8 mm.
Optional: interlock protection for more than 8 mm holes plates.

2. Opzionale: paraspruzzi
Optional: splash guard

3. Estrattore piastre
Plates removal tool

- AISI 304 stainless steel construction.
- Can be sprayed.
- 5 Hp and 7 Hp three-phase motors.
- Oil-bath, water protected gear box.

Grinding set:

- Completely made from AISI 304 stainless steel.
- Designed for high performance
- Machine works perfectly even if product is processed two or more times
- Hourly output: 1.100 Kg (actual) (42)
- Hourly output: 3500 kg (possible)
- Unprocessed meat inside grinding set at working cycle end: 50-90 g.
- Stainless steel drive pin.
- **Exclusive, patented plate and ring nut detection system (CE)**
- Tempered steel worm pin.
- Grinding set is quickly disassembled of faster cleaning and sanitation.
- Square feeding "neck" allows for faster processing cycles.
- Large 563x900 x h 120 mm feeding hopper with safety microswitch
- IP 67 water protected stainless steel controls with reverse (on CE versions).

Standard accessories:

- Stainless steel self-sharpening knife and 4,5 mm plate
- Product pusher
- Worm and plate removing tool
- Use and maintenance manual

Optional:

- FULL CONTROLS for accessories handling
- Stainless steel splash guard

- Pedal control
- Stainless steel 1/2 unger grinding set
- Stainless steel total unger grinding set
- Longer head (42)
- Interlock protection for more than 8 mm holes plates. (An interlock protection system is required in order to utilize more than 8 mm holes plates).
- Wide selection of plates and knives
- FORMAT S
- FORMAT A

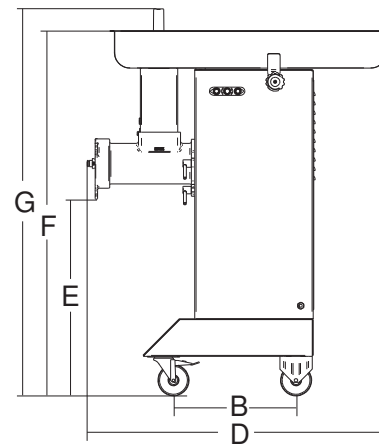
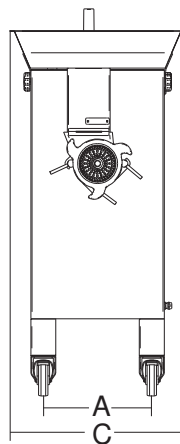

	Potenza Power Spannung Puissance	Alimentazione Power source Betriebsspannung Alimentation	Prod. oraria TC TC Output/h. TC Leistung/h. TC Débit/h.	Plastra in dotazione Standard Plate Scheibe Filtres	A	B	C	D	E	F	G	Peso netto Net weight Nettogewicht Poids net	Dimensioni imballo Shipping Verpack. abmessungen Dim. emballage	Peso lordo Gross weight Bruttogewicht Poids brut
	watt/HP		Kg/H.	ø mm	mm	mm	mm	mm	mm	mm	mm	Kg	mm	kg
TC 32 Montana Y12	2940/4	230-400V/50Hz	700	4,5	348	393	564	911	654	1169	1237	90	1050x950x1960	115
TC 42 Montana Y12 - Hp 5	3675/5	230-400V/50Hz	800-1000	4,5	348	393	564	973	631	1171	1241	112	1050x950x1960	137
TC 42 Montana Y12 - Hp 7	5145/7	230-400V/50Hz	1200-1300	4,5	348	393	564	973	631	1171	1241	112	1050x950x1960	137
TC 42 Montana Y12 Tramoggia gigante/Oversize tray					348	393	626	1125	631	1282	1282	128	1050x950x1960	153
TC 42 Montana Y12 Bocca lunga/Longer head					348	393	564	1063	631	1171	1241	132	1050x950x1960	157
TC 42 Montana Y12 Tramoggia gigante+ Bocca lunga Oversize tray+ Longer head					348	393	626	1215	631	1282	1282	148	1050x950x1960	173

Potencia
Potência
Мощность
功率

Alimentación
Alimentação
Электропитание
電源

Producción/h.
TC produção/h.
TC产量/小时

Placa en dotación
Lâmina em dotação
Решётка
标配刀盘

A B C D E F G

Peso neto
Peso líquido
Бесчёрно
净重

Dimensiones embalaje
Dimensões embalagem
Размеры упаковки
包装尺寸

Peso bruto
Peso bruto
Бес брутто
毛重



MASTER

tritacarne - impastatrice meat grinders - meat mixers



- Costruzione in acciaio inox AISI 304 lavabile con spruzzo d'acqua.
- 2 motori indipendenti IP x5 per tritacarne e convogliatore:
- Hp 1.5 per pala mescolatore/convogliatore
- Hp 5 o Hp 7 per tritacarne 42
- Hp 4 per tritacarne 32
- Riduttori angolari ermetici a bagno d'olio
- Micro di sicurezza su coperchio vasca
- Auto-apertura coperchio gestita da pistoni ad aria
- Comandi in acciaio inox IP 67 con inversione di marcia su TC

Gruppo macinazione:

- Completamente in acciaio inox AISI 304
- Studiata per grandi prestazioni
- Perno trascinatore in acciaio inox
- Perno elica in acciaio temperato
- Smontaggio rapido bocca e pala senza l'uso di attrezzi
- **Esclusivo sistema brevettato di controllo presenza piastra su 42.**

- *AISI 304 stainless steel construction. Can be sprayed.*
- *2 independent IP x5 motors for grinder and mixer:*
- *1.5 Hp mixer motor*
- *5 Hp or 7Hp meat grinder motors (42 model)*
- *4 Hp meat grinder motor (32 model)*
- *Oil-bath, waterproof angular gear box*
- *Safety microswitch on meat mixer cover*
- *Air pistons open the cover*
- *IP 67 stainless steel controls (reverse available for grinder)*

Grinding set:

- *Completely made of AISI 304 stainless steel*
- *Designed for high performance*
- *Stainless steel drive pin*
- *Tempered steel worm pin*
- *Grinding set and mixing arm can be easily disassembled without tools*
- **Exclusive, patented plate detection system on 42**



MASTER 90 Y12

Dotazione standard:

- Coltello e piastra diam. 4,5 autoaffilanti inox
- Struttura autoportante con ruote inox con freno
- Attrezzo estrazione elica e piastre

Standard accessories:

- *Stainless steel self-sharpening knife and 4,5 mm plate*
- *Floor support with stainless steel wheels and brake*
- *Worm and plate removing tool*



MASTER 30 Y12

MASTER 60



1. Opzionale: sistema di protezione interbloccato per uso piastre con foro > 8 mm.
Optional: interlock protection for more than 8 mm holes plates.



2. Opzionale: paraspruzzi
Optional: splash guard



3. Coperchio con sollevamento automatico
Lid with self lifting



4. Sistema comandi Full Control (per Format S-A)
Full Control system (for Format S-A)



Optional disponibili:

- Paraspruzzi inox
- Protezione bocca interbloccata per piastre con foro > 8 mm
- Bocca unger parziale o totale inox

Comandi FULL CONTROL con:

- Funzionamento temporizzato
- Inversione di marcia temporizzata su pala mescolatore
- Possibilità di collegamento accessori quali:
 - pedaliera
 - hamburgeratrice semiautomatica Format S
 - hamburgeratrice automatica Format A

Optional:

- *Stainless steel splash guard*
- *Safety device for Ø>8mm plates*
- *Stainless steel 1/2 or total unger grinding set*

FULL CONTROL:

- *Timer function*
- *Reverse with timer for meat mixer*
- *Optional connections for:*
 - *pedal controls*
 - *Format S - semi-automatic hamburger press attachment*
 - *Format A - automatic hamburger press attachment.*



MASTER 90 Y12 con FORMAT S



MASTER 90 Y12 con FORMAT A



5. Estrattore piastre
Plates removal tool



Standard o enterprise 1/2 Unger Unger Totale

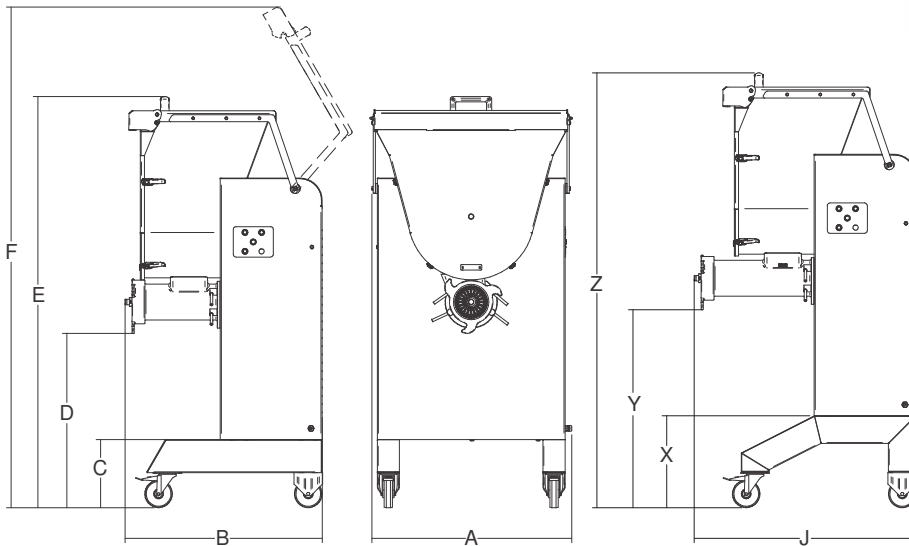

MASTER 90 Y12
gambe alte opzionali
optional high legs
X: 333 mm / Y: 717 mm
Z: 1575 mm / J: 806 mm

	Potenza TC TC Power TC Spannung Puissance TC	Potenza IP IP Power IP Leistung Puissance IP	Alimentazione Power source Betriebsspannung Alimentation	Capacità vasca Tank capacity Becken Kapazität Capacitat cuve	Placina in dotazione Standard Plate Scheibe Filtères	Giri/min Revolutions Umdrehungen Tours	Prod. oraria Output/h Leistung/h. Débit/h.	A	B	C	D	E	F	Peso netto Net weight Nettogewicht Poids net	Dimensioni imballo Shipping Verpack abmessungen Dim. emballage	Peso lordo Gross weight Bruttogewicht Poids brut
	watt/Hp	watt/Hp		Kg/lit	ø mm	r.p.m.	kg/h.	mm	mm	mm	mm	mm	mm	Kg	mm	kg
Master 30 Y12	2940/4	1102/1,5	230-400V/50Hz	30/42	4,5	TC 200 / IP 30	600-850	644	658	247	589	1243	1477	140	870x840x1700	165
Master 60	2940/4	1102/1,5	230-400V/50Hz	60/80	4,5	TC 186 / IP 30	850-1000	670	732	247	655	1416	1694	160	870x840x1700	185
Master 90 Y12 - Hp 5	3675/5	1102/1,5	230-400V/50Hz	90/120	4,5	TC 186 / IP 30	1000-1200	724	714	247	631	1489	1813	191	870x840x1700	216
Master 90 Y12 - Hp 7	5145/7	1102/1,5	230-400V/50Hz	90/120	4,5	TC 186 / IP 30	1000-1200	724	714	247	631	1489	1813	191	870x840x1700	216

Potencia TC
TC Power
TC Spannung
Puissance TC
Mощность TC мессоруби
TC功率

Potencia IP
IP Power
IP Leistung
Puissance IP
Mощность IP мешалки
IP功率

Alimentación
Alimentado
Электроснабжение
電源

Capacidad tina
Capacitate recipiente
Объем бункера
容器容积

Placa en dotación
Lamina em dotação
Решетка
标配刀盘

Vueltas
Giros
Обороты
转速

Producción/h
Produção/h
Производительность
产量/小时

A

B

C

D

E

F

Peso netto
Peso líquido
Вес нетто
净重

Dimensiones embalaje
Dimensões embalagem
Размеры упаковки
包装尺寸

Peso bruto
Peso brutto
Вес брутто
毛重



FORMAT

applicazioni hamburgatrici
hamburger presses attachments



FORMAT M

Stampi opzionali
Optionals moulds

Applicabile su / Applicable on:

COLORADO - BARCELONA - BARCELONA ICE - NEVADA - NEVADA ICE



Ø 100 mm / gr 140 c.

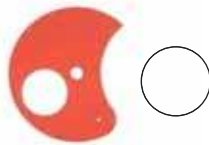

Ø 110 mm / gr 155 c.

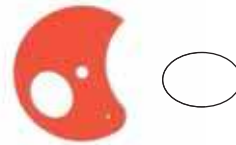

96x115 mm / gr 130 c.



100x100 mm / gr 150 c.



100x125 mm / gr 190 c.



90x117 mm / gr 105 c.



Ø 40 mm / gr 20 (x4) c.

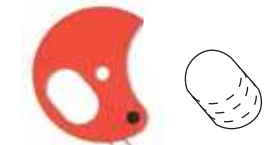

Regolabile 100-200 gr.
da tondo a "ovale"
Adjustable 100-200 gr. - round to oval

FORMAT S

Semiautomatica
Stampo fisso tondo Ø 100 mm

Semi-automatic
Round fixed mould Ø 100 mm

Applicabile su / Applicable on:
MONTANA - MASTER



YouTube

FORMAT S



FORMAT S

FORMAT A



FORMAT A



YouTube

Automatica
Stampo fisso tondo Ø 110 mm

Automatic
Round fixed mould Ø 110 mm

Applicabile su / Applicable on:
MONTANA - MASTER



KATANA 6 - 12

cutter orizzontali

horizontal cutters



- Completamente realizzato in acciaio inox AISI 304
- Lame guidate da potente motore asincrono ventilato.
- Robusta vasca in acciaio inox AISI 304, smontabile.
- Coperchio interbloccato facilmente smontabile per agevolare pulizia e sanificazione.
- Comandi con pulsanti inox IP 67.
- Mozzo lame facilmente rimovibili.
- Mozzo con 3 lame di serie.
- Disponibili mozzo lame specifici per lavorazioni particolari.
- Massima protezione infiltrazione liquidi sull'albero.
- Ideali per carni e verdure ma adatto anche a molteplici altre lavorazioni.
- **Katana 12 PTO**
Disponibile anche con presa di forza per accessori opzionali standard come TC, TV (solo non CE).



KATANA 12 VV

KATANA 6
Piedini opzionali



Katana 12 PTO

- Completely made in AISI 304 stainless steel
- Blade driven by powerful ventilated asynchronous motor
- Sturdy, removable AISI 304 stainless steel bowl
- Easily removable interlocking lid to facilitate cleaning and sanitising
- Controls with IP 67 stainless steel buttons
- Easily removable blade hub
- Hub with 3 blades standard.
- Dedicated knives available for special purposes.
- Maximum protection against liquid infiltration on the shaft.
- Perfect for meat and vegetables, but also suitable for many other types of processing.
- **Katana 12 PTO**
Also available with PTO for optional accessories like TC, TV (only non CE).



Standard
1 Mozzo a 3 lame
Hub 3 blades



Optional
2 Mozzo a 3 lame dentate
Hub 3 serrated blades



Optional
3 Mozzo a 3 lame non affilate
Hub 3 blunt blades

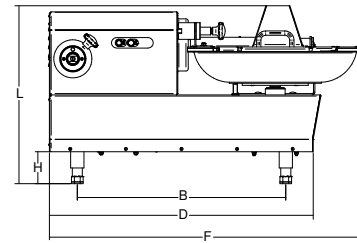
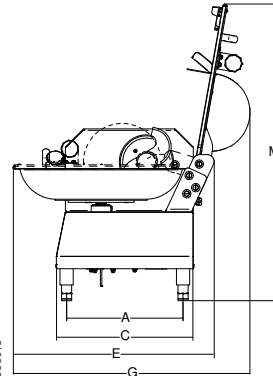

	Potenza Power Spamung Puissance	Alimentazione Power source Betriebsspannung Alimentation	Lame Blades Messer Lame	Capacità vasca Tank capacity Becken Kapazität Capacité cuve	Giri Revolutions Umdrehungen messers Tours	A	B	C	D	E	F	G	H	L	M	Peso netto Net weight Nettogewicht Poids net	Dimensioni imballo Shipping Verpack. abmessungen Dim. emballage	Peso lordo Gross weight Bruttogewicht Poids brut
	watt/Hp		n.	lt/kg	r.p.m.	mm	mm	mm	mm	mm	mm	mm	mm	mm	mm	Kg	mm	kg
Katana 6	370/0,5	230V/50Hz	3	6/4,5	1.440	297	540	356	714	516	832	582	92	472	760	60	1200x670x800	73
Katana 12	750/1	230-400V/50Hz	3	12/9	1.440	335	600	393	758	587	902	680	92	508	850	75	1200x670x800	88
Katana 12 VV	750/1	230V/50Hz	3	12/9	600/2.600	335	600	393	758	587	902	680	92	508	850	75	1200x670x800	88
Katana 12 PTO	750/1	230-400V/50Hz	3	12/9	1.440	335	600	393	758	587	902	680	92	508	850	75	1200x670x800	88

Potencia
Potência
Мощность
功率

Alimentación
Alimentação
Электропитание
電源

Cuchillas
Lâminas
Ламы
刀片

Capacidad tina
Capacidade recipiente
Объем бункера
容器容量

Vueltas
Giros
Обороты
转速

A

B

C

D

E

F

G

H

L

M

Peso neto
Peso líquido
Вес нетто
净重

Dimensiones embalaje
Dimensões embalagem
Размеры упаковки
包装尺寸

Peso bruto
Peso bruto
Вес брутто
毛重



KATANA 6



KATANA 12 PTO



KATANA 12 PTO



KATANA 20

cutter orizzontale

horizontal cutter

- Completamente realizzato in acciaio inox AISI 304.
- Lame guidate da potente motore asincrono ventilato.
- Variatore di velocità continuo gestito da inverter.
- Motoriduttore vasca indipendente.
- Robusta vasca in acciaio inox AISI 304 smontabile.
- Coperchio interbloccato facilmente smontabile per agevolarne la pulizia.
- Comandi con pulsanti inox IP 67.
- Mozzo con 3 lame di serie facilmente rimovibile (configurabile a 2 lame).
- Disponibili mozzi lame specifici per lavorazioni particolari.
- Massima protezione infiltrazione liquidi sull'albero.
- Ideali per carni e verdure ma adatto anche a molteplici altre lavorazioni.

- Completely made in AISI 304 stainless steel.
- Blade driven by powerful ventilated asynchronous motor.
- Continuous speed control controlled by inverter.
- Independent bowl gearbox.
- Sturdy AISI 304 stainless steel bowl is removable and can be rotated manually to facilitate unloading and cleaning.
- Easily removable interlocking lid to facilitate cleaning.
- Controls with IP 67 stainless steel buttons.
- Easily removable blade hub with 3 blades standard (configurable to 2 blades).
- Dedicated knives available for special purposes.
- Maximum protection against liquid infiltration on the shaft.
- Perfect for meat and vegetables, but also suitable for many other types of processing.



Standard
1 Mozzo a 3 lame
Hub 3 blades

Optional
2 Mozzo a 3 lame dentate
Hub 3 serrated blades

Optional
3 Mozzo a 3 lame non affilate
Hub 3 blunt blades

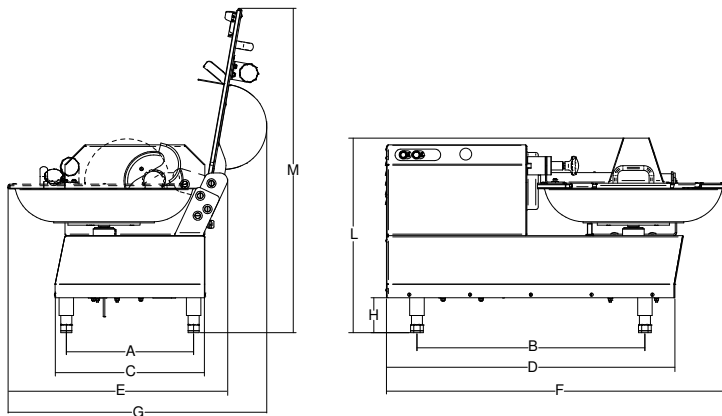

	Potenza Power Spannung Puissance	Alimentazione Power source Betriebsspannung Alimentation	Lame Blades Messer Lame	Capacità vasca Tank capacity Becken Kapazität Capacité cuve	Giri Revolutions Umdrehungen Tours	A	B	C	D	E	F	G	H	L	M	Peso netto Net weight Nettogewicht Poids net	Dimensioni imballo Shipping Verpack abmessungen Dim. emballage	Peso lordo Gross weight Bruttogewicht Poids brut
	watt/Hp	n.	lt/kg	r.p.m.	mm	mm	mm	mm	mm	mm	mm	mm	mm	mm	mm	Kg	mm	kg
Katana 20 VV	2.200/3	230V/50Hz	3	20/15	600/2.600	390	650	450	820	700	1013	822	92	572	1010	92	1000x1200x800	105
	Potencia Potência Мощность 功率	Alimentação Alimentação Электропитание 電源	Cuchillas Lâminas Коп-во лезвий 刀片	Capacidad línea Capacidade reservente Объем бункера 容器容积	Vueltas Giros Обороты 转速	A	B	C	D	E	F	G	H	L	M	Peso netto Peso líquido Вес нетто 淨重	Dimensiones embalaje Dimensões embalagem Размеры упаковки 包裝尺寸	Peso bruto Peso bruto Вес брутто 毛重





IP 10-20 M

impastatrici per carne

meat mixers



Pratiche e compatte, ideali per piccoli impasti, sia in macelleria che ristorazione.

- Costruzione in acciaio inox Aisi 304.
- Riduttore a bagno d'olio con ingranaggi elicoidali temprati e rettificati.
- Sistema di protezione ingranaggi con doppio paraolio.
- Motori asincroni ventilati IP x5.
- Coperchio con micro di sicurezza.
- Pala in acciaio inox Aisi 304 facilmente rimovibile senza attrezzi.
- Comandi IP54 con inversione.

Practical and compact, ideal for small mixing jobs in butcher shops and restaurants.

- Made of Aisi 304 stainless steel.
- Oil bath gear reducers with hardened and ground helical gears.
- Gear protection system with double seal.
- IP x5 ventilated, asynchronous motors
- Cover with safety micro switch.
- Aisi 304 stainless steel blade that is easily removed without tools.
- IP54 controls with inversion.



IP 20 M



IP 10 M

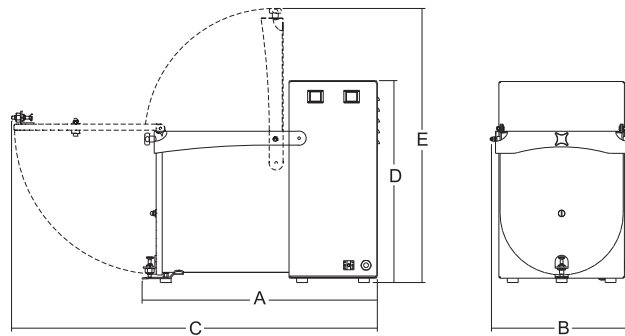

	Potenza Power Spannung Puissance	Alimentazione Power source Betriebsspannung Alimentation	Dimensioni vasca Tank dimensions Becken abmessungen Dimensions cuve	Capacità Capacity Kapazität Capacité	A	B	C	D	E	Peso netto Net weight Nettogewicht Poids net	Dimensioni imballo Shipping Verpack abmessungen Dim. emballage	Peso lordo Gross weight Brutogewicht Poids brut
	watt/Hp		mm	lt/Kg	mm	mm	mm	mm	mm	Kg	mm	kg
IP 10 M	180/0,25	230V/50Hz	200x250	14/10	472	255	757	410	565	18	800x600x520	20,5
IP 20 M	370/0,50	230V/50Hz	270x300	28/20	554	330	445	646	634	27	720x570x770	49

Potencia
Potência
Мощность
功率

Alimentación
Alimentação
Электропитание
电源

Dimensiones cuba
Dimensões tanque
Размеры ванны
攪拌槽容積

Capacidad
Capacidade
Вместимость
容積

A

B

C

D

E

Peso neto
Peso líquido
Вес нетто
淨重

Dimensiones embalaje
Dimensões embalagem
Размеры упаковки
包裝尺寸

Peso bruto
Peso bruto
Вес брутто
毛重



1. Pala facilmente rimovibile
Removable mixing arm





YouTube

IP 30-50 M Y14



impastatrici per carne meat mixers



IP 50 M Y14

Gambe con ruote opzionali
Optional legs with wheels

- Costruzione in acciaio inox Aisi 304.
- Potente motore.
- Riduttore a bagno d'olio con ingranaggi elicoidali temperati e rettificati.
- Sistema di protezione ingranaggi con doppio paraolio.
- Coperchio con micro di sicurezza.
- Pala in acciaio inox Aisi 304 facilmente rimovibile senza attrezzi.
- Sportello vasca apribile per rimozione pala e impasto.
- Comandi in acciaio inox IP 67 con inversione.
- **Opzioni:**
Gambe inox basse, medie e alte con ruote.
Tramoggia aggiunta ingredienti.
- *Made from AISI 304 stainless steel.*
- *Ventilated motor.*
- *Oil-bath gear box, ground and tempered helical gears.*
- *Gear box with double sealing system.*
- *Safety microswitch on the cover.*
- *Removable AISI 304 stainless steel mixing arm (no tools required).*
- *Front outlet opening for shaft removal and product unload.*
- *Stainless steel IP 67 protection rated controls with reverse.*
- **Optional:**
Short, medium, long legs with wheels.
Feeding tray to add ingredients.



1. IP 30 M Y14



2. Comandi IP 67 in acciaio inox
Stainless steel IP 67



3. IP 50 M Y14



4. Opzione tramoggia per aggiunta ingredienti
Optional feed tray for add ingredients



IP 30 M Y14



IP 30M Y14



IP 50-120 M-B

impastatrici per carne

meat mixers

- Costruzione con mobile e ruote in acciaio inox AISI 304.
- Vasca ribaltabile per lo scarico.
- Pale in acciaio inox AISI 304 facilmente rimovibili senza attrezzi.
- Sistema di riduzione a doppio stadio cinghie-ingranaggi.
- Comandi in acciaio inox IP67 con inversione.
- Coperchio con micro di sicurezza.
- Sistema Monopala.
- Semplice ed immediato.
- Ideale anche per impasti duri e insalate.
- Sistema Bipala ideale per carni fresche:
- Veloce mescola grazie all'esclusivo sistema con raschiatore.
- Capacità minima pari a 10% capienza vasca.
- AISI 304 stainless steel base and castors.
- Tilting tank.
- Removable AISI 304 stainless steel blades (no tools required).
- Belt and gear drive.
- IP 67 stainless steel controls with reverse.
- Safety microswitch on the cover.
- M version (single mixing arm)
- Simple and easy to use.
- Perfect for hard mix and salad.
- B version (one shaft + one scraping blade) perfect for fresh meat mix:
- Fast mixing thanks to the exclusive scraping blade.
- Minimum loading required: 10% max capacity.



IP 120



1. IP 50 - IP 120 B



2. IP 50-120 M



3. Comandi IP 67 in acciaio inox
Stainless steel IP 67 controls

USO/USE

IMPASTI MOLTO DURI (patate e farina)
VERY HARD MIXTURES (potatoes and wheat)

IMPASTI DURI (carne fresca + addensanti)
HARD MIXTURES (fresh meat + solids)

IMPASTI MEDI (carne fresca)
MEDIUM MIXTURES (fresh meat)

IMPASTI LIQUIDI (carne fresca + liquidi)
SOFT MIXTURES (fresh meat + liquids)

PRODOTTI SECCHI (spezie e polveri)
DRY MIXTURES (powders and spices)

INSALATE
SALADS

	IP 10/20 M	IP 30/50 M Y14	IP 50 M	IP 50 B	IP 120 M	IP 120 B	IP 50-80 XP BA	IP 120-180 XP BA
IMPASTI MOLTO DURI	Red	Red	Red	Red	Red	Red	Red	Red
IMPASTI DURI	Red	Red	Red	Red	Red	Red	Red	Red
IMPASTI MEDI	Green	Green	Green	Green	Green	Green	Green	Green
IMPASTI LIQUIDI	Green	Green	Green	Green	Green	Green	Green	Green
PRODOTTI SECCHI	Green	Green	Green	Green	Green	Green	Green	Green
INSALATE	Green	Green	Green	Green	Green	Green	Green	Green

- Ideale per l'uso
Ideal for the use
- Utilizzabile con pala specifica
Usable with recommended shaft
- Utilizzabile
Usable for this product
- Sconsigliata
Not recommended for this use



IP 50



IP 50-80-120-180 XP BA

impastatrici per carne meat mixers



IP 180 XP BA

- Moderno design e robusta struttura in AISI 304 a forte spessore.
- Vasca ribaltabile con sistema di blocco automatico e blocco di sicurezza.
- Ruote inox girevoli e con freno (2).
- Sistema classico con 2 alberi affiancati.
- Pale in acciaio inox AISI 304 facilmente rimovibili senza attrezzi.
- Carter con protezione totale della parte riduttori/comandi.
- Riduttore a bagno d'olio con ingranaggi elicoidali temperati e rettificati.
- Protezione dai liquidi a doppio paraolio: su vasca e su riduttore.
- Sistema di controllo con comandi in acciaio inox IP 67 di serie:
 - marcia avanti e indietro
 - automatismo con autospegnimento
 - automatismo con inversione
- Coperchio in acciaio inox con micro di sicurezza.
- Carico minimo 40% capienza vasca.
- Ideale anche per impasti duri e insalate.

Opzionale:

- Tramoggia aggiunta ingredienti.

- Modern design and strong AISI 304 stainless steel construction
- Tilting tank with automatic locking system and safety lock
- Stainless steel swivel wheels with lock (2)
- Two mixing arms system
- Removable AISI 304 stainless steel mixing arms (no tools required)
- Total protection of gear box/control panel
- Oil-bath gear box, ground and tempered helical gears
- Double seal on tank and gear box
- Stainless steel IP 67 controls:
 - forward and reverse
 - auto-off feature
 - auto-function with reverse
- Stainless steel cover with safety microswitch
- Minimum loading required: 40% max capacity
- Perfect for hard mix and salad

Optional:

- Feeding tray to add ingredients.



1. Ribaltamento vasca
Tank overturn



2. Pale facilmente rimovibili
Removable mixing arms



push	x1	o / or	x1	Manuale continuo Manual continuous
	x2	o / or	x2	Timer 1 Min
	x1	+	x1	Inversione auto 2 min Auto reverse 2 min

3. Sistema di controllo
Control system



IP 50 XP BA



IP 80 XP BA



IP 120 XP BA

IP 30-50 M Y14

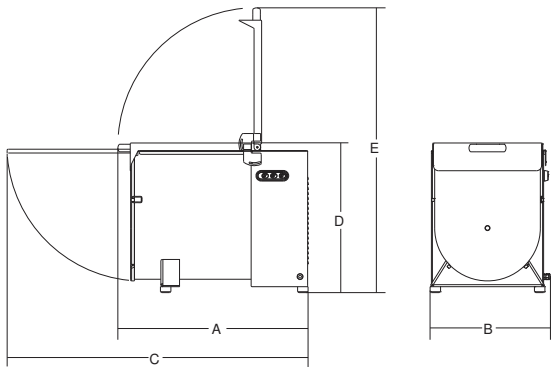

IP 30-50 M Y14 optionals

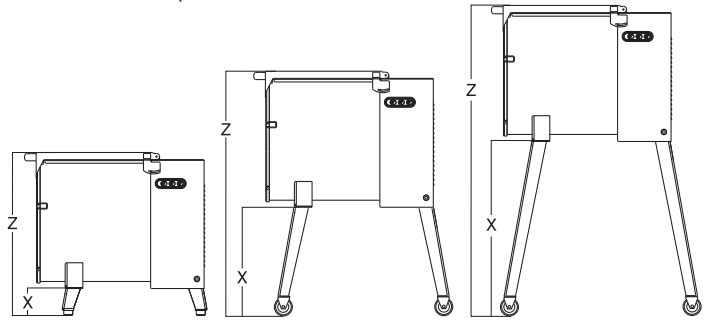

Gambe basse con piedino
Short legs with feet

Gambe medie con ruote e freno
Medium legs with wheels and brake

Gambe alte con ruote e freno
Longer legs with wheels and brake

IP 30 M Y14
X: 150 mm / Z: 650 mm
IP 50 M Y14
X: 150 mm / Z: 720 mm

IP 30 M Y14
X: 440 mm / Z: 940 mm
IP 50 M Y14
X: 440 mm / Z: 1010 mm

IP 30 M Y14
X: 610 mm / Z: 1110 mm
IP 50 M Y14
X: 610 mm / Z: 1180 mm

IP 50-120 M-B

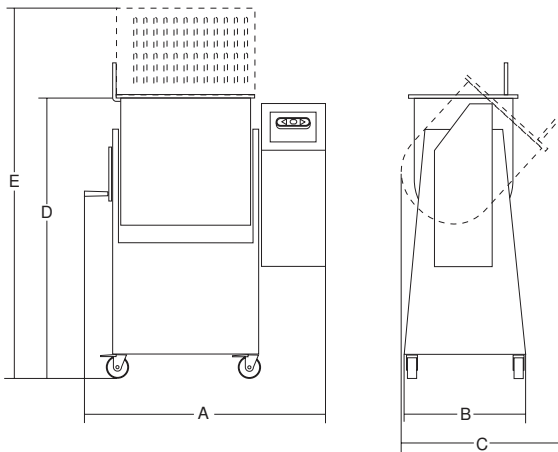

IP 50-80-120-180 XP B/A

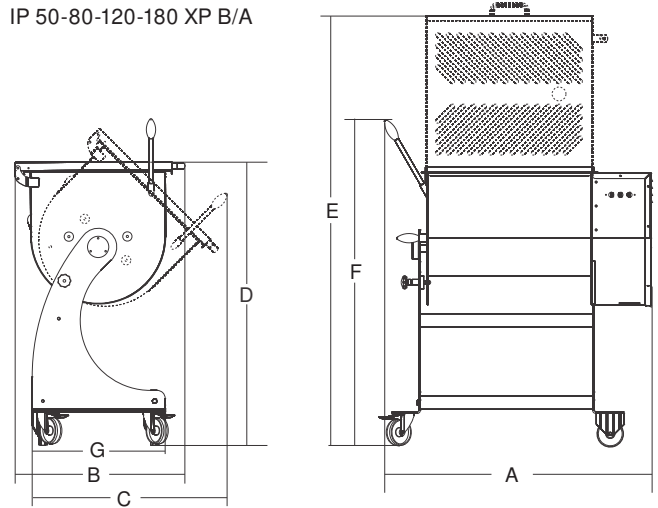

Potenza
Power
Spannung
Puissance

Alimentazione
Power source
Betriebsspannung
Alimentation

Dimensioni vasca
Tank dimensions
Becken abmessungen
Dimensions cuve

Capacità
Capacity
Kapazität
Capacité

Peso netto
Net weight
Nettogewicht
Poids net

Dimensioni imballo
Shipping
Verpack abmessungen
Dim. emballage

Peso lordo
Gross weight
Brutogewicht
Poids brut

	watt/Hp		mm	lt/Kg	A	B	C	D	E	F	G	Kg	mm	kg
IP 30 M Y14	1ph 850/1,1 3ph 1100/1,5	230-400V/50Hz	300x400	42/30	680	365	1120	530	975	-	-	49	720x570x770	59
IP 50 M Y14	1ph 850/1,1 3ph 1100/1,5	230-400V/50Hz	410x480	88/50	750	465	1250	595	1120	-	-	59	870x840x760	74
IP 50 M New	1ph 850/1,1 3ph 1100/1,5	230-400V/50Hz	400x470	88/50	840	500	750	1075	1280	-	-	96	1200x670x1300	116
IP 50 B	1500/2	230-400V/50Hz	400x470	88/50	840	500	750	1075	1280	-	-	100	1200x670x1300	120
IP 120 M	1850/2,5	230-400V/50Hz	640x500	163/120	1000	500	820	1100	1300	-	-	125	1200x670x1300	145
IP 120 B	1850/2,5	230-400V/50Hz	640x500	163/120	1000	500	820	1100	1300	-	-	125	1200x670x1300	145
IP 50 XP BA	1ph 370/0,5 (x2) 3ph 530/0,7 (x2)	230-400V/50Hz	420x500	88/50	810	630	730	1030	1617	1220	500	85	1200x670x1300	105
IP 80 XP BA	1ph 370/0,5 (x2) 3ph 530/0,7 (x2)	230-400V/50Hz	620x500	110/80	1000	630	730	1030	1617	1220	500	90	1200x670x1300	110
IP 120 XP BA	1ph 750/1 (x2) 3ph 1100/1,5 (x2)	230-400V/50Hz	660x550	163/120	1092	700	855	1030	1717	1209	620	138	1450x750x1300	167
IP 180 XP BA	1ph 750/1 (x2) 3ph 1100/1,5 (x2)	230-400V/50Hz	995x550	250/180	1422	700	855	1030	1717	1209	620	152	1450x750x1300	182

Potencia
Potência
Мощность
功率

Alimentación
Alimentação
Электропитание
电源

Dimensiones cuba
Dimensões tanque
Размеры ванны
攪拌桶容積

Capacidad
Capacidade
Емкiстiсть
容積

Peso neto
Peso líquido
Вес нетто
淨重

Dimensiones embalaje
Dimensões embalagem
Размеры упаковки
包裝尺寸

Peso bruto
Peso bruto
Вес брутто
毛重



IS 8-16 X - IS 12 VX



Insaccatrici manuali manual sausage stuffers



IS 8-16 X

- Corpo e cilindro in acciaio inox AISI 304.
- Robusto cilindro raggiato e con doppia saldatura sul fondello.
- Pistone in nylon alimentare con valvola di sfiato aria.
- Scatola ingranaggi in acciaio zincato.
- Ingranaggi in acciaio temperato e rettificato.
- Scorrimento ingranaggi su 4 cuscinetti ermetici.
- Sistema riduzione a doppia velocità.
- In dotazione: 3 imbusti in nylon alimentare bianco. Morsetto fissaggio.

Opzionale: Cremagliera in acciaio inox.

- AISI 304 S/S body and cylinder.
- Sturdy cylinder with double welding on the bottom plate.
- Nylon pistons with air exhaust valve.
- Galvanized steel gear box.
- Ground and tempered steel gears.
- Gears sliding on 4 sealed bearings.
- 2 speed gear reducer.
- Standard: 3 nylon filling tubes. Fixing clamp.

Optional: Stainless steel rack.



1. Porta imbusti
Holder tunnels

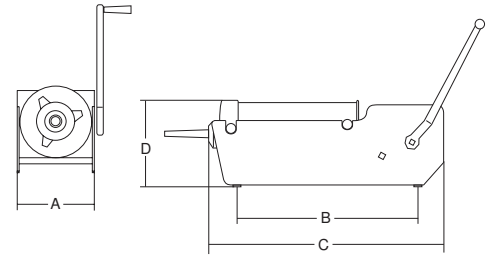
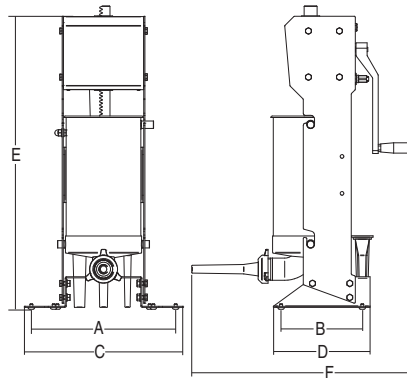

IS 12 VX

Capacità cilindro
Cylinder capacity
Inhalt Zylinder
Capacité Cylindre

Lunghezza cilindro
Cylinder length
Zylinder laenge
Longeur cylindre

Diametro cilindro
Cylinder diameter
Zylinder Durchmesser
Diamètre cylindre

Corsa pistone
Piston stroke
Kolben hob
Course piston

Imbusti in dotazione \varnothing int.
 \varnothing Serie exhaust funnels
 \varnothing Zusatzliche Trichter
 \varnothing Entnomm in dotation

A B C D E F

Peso netto
Net weight
Nettogewicht
Poids net

Dimensioni imballo
Shipping
Verpack abmessungen
Dim. emballage

Peso lordo
Gross weight
Bruttogewicht
Poids brut

	lt	mm	\varnothing mm	mm	\varnothing mm	mm	mm	mm	mm	mm	mm	Kg	mm	kg
IS 8 X	8	370	165	420	10-18-25	200	430	660	220	-	-	19	730x260x250	20
IS 16 X	16	500	200	560	10-18-25	240	575	820	250	-	-	23,5	890x310x280	24,5
IS 12 VX	12	380	200	420	10-18-25	400	190	435	250	794	602	24	890x310x280	26

Capacidad cilindro
Capacidade cilindro
Емкость цилиндра
筒容積

Longitud cilindro
Comprimento cilindro
Длина цилиндра
筒長度

Diametro cilindro
Диаметр цилиндра
筒直徑

Trayecto pistón
Curso pistón
Шар прохода
活塞行程

Embudos en dotación \varnothing int.
 \varnothing Funis em dotação
Внутр. \varnothing прилагаемых
воронков
直徑不同的系列漏斗

A B C D E F

Peso netto
Peso líquido
Вес нетто
淨重

Dimensiones embalaje
Dimensões embalagem
Размеры упаковки
包裝尺寸

Peso bruto
Peso bruto
Вес брутто
毛重



IS 12 VX

2. Ribaltamento cilindro
Cylinder overturn



IS 8-16 X



IS 8-16 X

3. Estrema facilità di pulizia
Very easy to clean



IS 8-16 ARIES

insaccatrici manuali

manual sausage stuffers



- Corpo e cilindro in acciaio inox AISI 304.
- Robusto cilindro raggiato e con doppia saldatura sul fondello.
- Pistone in nylon alimentare con valvola di sfogo aria.
- Scatola ingranaggi in acciaio zincato.
- Ingranaggi in acciaio temperato e rettificato.
- Scorrimento ingranaggi su 4 cuscinetti ermetici.
- Sistema riduzione a doppia velocità.
- In dotazione: 3 imbuto in nylon alimentare bianco. Morsetto fissaggio. Aries 12 con sistema di blocco cilindro per agevolarne il carico.

Opzionale: Cremagliera in acciaio inox.

- AISI 304 S/S body and cylinder.
- Sturdy cylinder with double welding on the bottom plate.
- Nylon pistons with air exhaust valve.
- Galvanized steel gear box.
- Ground and tempered steel gears.
- Gears sliding on 4 sealed bearings.
- 2 speed gear reducer.
- Standard: 3 nylon filling tubes. Fixing clamp. Aries 12 with easy loading device.

Optional: Stainless steel rack.



IS 8-16 ARIES



IS 8-16 ARIES

1. Scorrimento su cuscinetti
Running on ball bearings

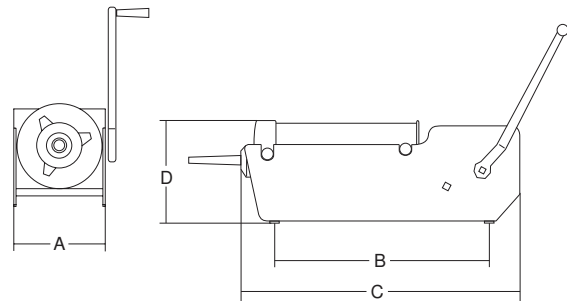

	Capacità cilindro Cylinder capacity Inhalt Zylinder Capacité Cylindre	Lunghezza cilindro Cylinder length Zylinder laenge Longeur cylindre	Diametro cilindro Cylinder diameter Zylinder Durchmesser Diamètre cylindre	Corsa pistone Piston stroke Kolben hob Course piston	Imbuto in dotazione ø int. Ø Serie exhaust lumelis Ø Zusatzliche trichter Ø Entnoir en dotation	A	B	C	D	Peso netto Net weight Nettogewicht Poids net	Dimensioni imballo Shipping Verpack. abmessungen Dim. emballage	Peso lordo Gross weight Bruttogewicht Poids brut
	lit	mm	ø mm	mm	ø mm	mm	mm	mm	mm	Kg	mm	kg
IS 8 Aries	8	370	165	420	10-18-25	200	430	660	220	23	730x260x250	24
IS 16 Aries	16	500	200	560	10-18-25	240	575	820	250	28	890x310x280	29
	Capacidad cilindro Capacidade cilindro Емкость цилиндра 筒容积	Longitud cilindro Comprimento cilindro Длина цилиндра 筒长度	Diametro cilindro Ø Diámetro cilindro Диаметр цилиндра 筒直径	Treyecto pistón Curso pistão Шертопура 活塞行程	Embudos en dotación Ø int. Ø Funis em dotação Ø Funis em dotação Внутр.ø прилагаемых воронок 直径不同的系列漏斗	A	B	C	D	Peso netto Peso líquido Вес нетто 净重	Dimensiones embataje Dimensões embatagem Размеры упаковки 包装尺寸	Peso bruto Peso bruto Вес брутто 毛重



IS 16-30-50 IDR. O RIZ.

Insacatrici orizzontali hydraulic sausage stuffers



IS 30 IDR. ORIZ.

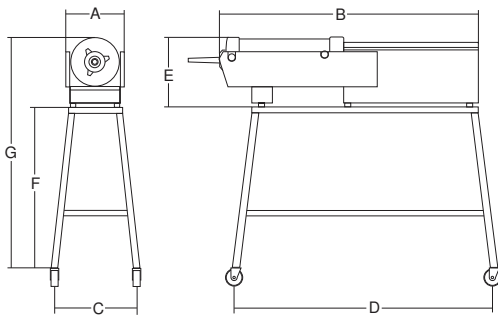

1. Ribaltamento cilindro
Cylinder overturn



2. Protezione cilindro e valvole sfiato aria
Cylinder protection and pad exhaust valves

- Macchine insacatrici di semplice concezione, ma realizzate con materiali e accorgimenti di alta qualità.
- Robusta struttura realizzata in acciaio inox.
- Macchina completamente lavabile mediante spruzzo d'acqua.
- Cilindro in acciaio inox AISI 304 conforme alle recenti norme igienico sanitarie raggiato e senza resto di saldatura interna, per consentire una semplice pulizia.
- Completamente a norme antinfortunistiche con protezione sul cilindro e comando a pedale a bassa tensione.
- Pistoni provvisti di valvole per lo sfiato dell'aria.
- Avanzamento pistone regolabile mediante un pomello.
- Ritorno pistone sempre a velocità massima.
- Completa di imbusti in polietilene di tre differenti misure, a richiesta inox.

- Machines of simple design, but manufactured with high quality materials and details:
- Strong structure made of stainless steel.
- Completely cleanable by means of a water sprinkle.
- Stainless steel AISI 304 cylinder standing to the newest sanitary-hygienic norms, with no edge inside of it and no weld rests, to simplify the cleaning.
- Completely realized standing to the most up to date accidental prevention norms, with protection on cylinder and low tension treadle drive.
- Pistons provided with air exhaust valve.
- Forward feeding adjustable by means of knob.
- Backward feeding always at highest speed.
- Complete with three polyethylene funnels of different sizes, stainless steel funnels on request.

	Potenza Power Spannung Puissance	Capacità cilindro Cylinder capacity inhalt Zylinder Capacité cylindre	Lunghezza cilindro Cylinder length Zylinder lange Longeur cylindre	Diametro cilindro Cylinder diameter Zylinder Durchmesser Diamètre cylindre	Corsa pistone Piston stroke Kolben hob Course piston	Velocità min. svuotamento Min. forward speed Langsamere vor. Bewegung Vitesse minimale vidage	Velocità max. svuotamento Max. forward speed Schnellere vor. Bewegung Vitesse maximale vidage	Velocità ritorno pistone Backward speed Rückwärts bewegung Vitesse retour piston	Imbusti in dotazione Ø int. Serie exhaust funnels Ø Zusätzliche trichter Ø Entnomm in dotation	A	B	C	D	E	F	G	Peso netto Net weight Nettogewicht Poids net	Dimensioni imballo Shipping Verpack abmessungen Dim. emballage	Peso lordo Gross weight Bruttogewicht Poids brut
	Watt/Hp	lit	mm	Ø mm	mm			Ø mm	mm	mm	mm	mm	mm	mm	mm	mm	Kg	mm	kg
IS 16 idr. oriz.	560/0,75	16	500	200	520	3' 30"	30"	16"	10-18-25	280	1310	440	1160	360	780	1120	71	1400x460 x550	78
IS 30 idr. oriz.	560/0,75	30	600	260	640	4' 10"	60"	30"	10-18-25	360	1580	440	1010	400	720	1100	111	1620x500 x500	120
IS 50 idr. oriz.	560/0,75	50	600	320	650	5' 40"	60"	30"	10-18-25	420	1650	500	1100	430	670	1100	153	1620x500 x500	174

	Potencia Potência Мощность 功率	Capacidad cilindro Capacidade cilindro 筒容 筒容	Longitud cilindro Comprimento cilindro 筒长度 筒长度	Diametro cilindro Diametro cilindro 筒直径 筒直径	Trajecto pistón Curso pistão 行程 行程	Velocidad min. vaciado Velocidade min. esvaziamento 筒小推速度 筒小推速度	Velocidad máx. vaciado Velocidade máx. esvaziamento 筒大推速度 筒大推速度	Velocidad regreso pistón Velocidade retorno pistão 筒返回速度 筒返回速度	Embusti en dotación Ø int. Ø Funis em dotação 筒不同系列筒嘴 筒不同系列筒嘴	A	B	C	D	E	F	G	Peso netto Peso líquido 筒重 筒重	Dimensiones embalaje Dimensões embalagem 筒装尺寸 筒装尺寸	Peso bruto Peso bruto 筒重 筒重
IS 16 IDR. INOX	560/0,75	16	500	200	520	3' 30"	30"	16"	10-18-25	280	1310	440	1160	360	780	1120	71	1400x460 x550	78
IS 30 IDR. INOX	560/0,75	30	600	260	640	4' 10"	60"	30"	10-18-25	360	1580	440	1010	400	720	1100	111	1620x500 x500	120
IS 50 IDR. INOX	560/0,75	50	600	320	650	5' 40"	60"	30"	10-18-25	420	1650	500	1100	430	670	1100	153	1620x500 x500	174



IS 16 IDR. INOX



IS 30 IDR. INOX



IS 50 IDR. INOX



IDRA 15-25-35-50

Insaccatrici verticali vertical hydraulic sausage stuffers



- Semplici e funzionali, le nuove insaccatrici idrauliche verticali IDRA contano su di un potente impianto idraulico che lavora a 120 Bar di pressione.
- Costruite interamente in acciaio inox, totalmente smontabili per la pulizia senza l'uso di attrezzi, vantano caratteristiche proprie di modelli di classe superiore:
 - . coperchio e tampone totalmente in acciaio inox;
 - . guarnizioni al silicone che agiscono all'interno del cilindro per una maggiore tenuta e durata della guarnizione stessa;
 - . protezione ermetica cilindro oleodinamico;
 - . stelo pistone in acciaio inox;
 - . cilindro in acciaio inox, lucidato e ribordato, senza verso obbligato;
 - . potente e silenzioso motore ventilato a 2.800 giri ad azione immediata;
 - . ritorno pistone automatico con spegnimento motore;
 - . comandi 24 V;
 - . regolatore flusso olio di alta precisione;
 - . ruote gommata di serie;
 - . serbatoio olio con indicatore di livello.

- *Simple and functional, the new IDRA hydraulic vertical sausage fillers feature a powerful hydraulic system that operates at a pressure of 120 bars.*
- *Manufactured entirely from stainless steel, the machine can be completely disassembled for easy cleaning without requiring tools. It features characteristics typical of higher category models:*
 - . *fully stainless steel cover and piston;*
 - . *silicone gaskets that act inside the cylinder for better seal and longer life of the gasket;*
 - . *hermetic protection of the hydraulic cylinder;*
 - . *stainless steel piston rod;*
 - . *polished and rounded stainless steel cylinder, without obligatory direction;*
 - . *powerful and silent ventilated motor operating at 2,800 rpm with immediate action;*
 - . *automatic piston return when motor stops;*
 - . *24V controls,*
 - . *high-precision oil flow controller;*
 - . *standard rubber wheels;*
 - . *oil tank with level gauge.*



IS 25 IDRA



1. Guarnizione ermetica su cilindro oleodinamico
Hermetic hydraulic piston gasket



2. Azionamento spinta pistone
Piston pushing up



3. Ritorno pistone automatico
Automatic piston return



4. Particolare centralina e comandi
Electric station and controls



IS 15 IDRA



IS 35 IDRA



IS 50 IDRA

Opzionali / Optional:



5. Ghiera inox
Bush in stainless steel



6. Imbuti inox (ø 13-16-20-25-28-38)
Funnels in stainless steel (ø 13-16-20-25-28-38)

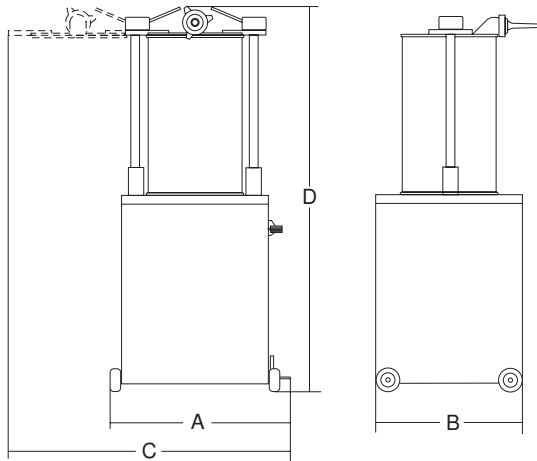

7. Estrema facilità di pulizia
Very easy to clean

	Potenza Power Spannung Puissance	Capacità cilindro Cylinder capacity Inhalt Zylinder Capacité Cylindre	Lunghezza cilindro Cylinder length Zylinder länge Longeur cylindre	Diametro cilindro Cylinder diameter Zylinder Durchmesser Diamètre cylindre	Corso pistone Piston stroke Kolben hob Course piston	Velocità min. svuotamento Min. forward speed Langsamere vor. Bewegung Vitesse minimale vidage	Velocità max. svuotamento Max. forward speed Schnellere vor. bewegung Vitesse maximale vidage	Velocità ritorno pistone Backward speed Rückwärts bewegung Vitesse retour piston	Imbuti in dotazione ø int. ø Serie exhaust funnels ø Zusätzliche trichter ø Entnoir en dotation	A	B	C	D	Peso netto Net weight Nettogewicht Poids net	Dimensioni imballo Shipping Verpack. abmessungen Dim. emballage	Peso lordo Gross weight Bruttogewicht Poids brut
	Watt/Hp	lit	mm	ø mm	mm				ø mm	mm	mm	mm	mm	Kg	mm	kg
IS 15 Idra	560/0,75	15	495	200	430	2' 11"	59"	35"	10-18-25	490	370	700	1200	53	720x570 x1380	63
IS 25 Idra	560/0,75	25	460	260	380	2' 02"	51"	32"	10-18-25	565	450	950	1160	91	720x570 x1380	103
IS 35 Idra	560/0,75	35	460	320	380	2' 02"	51"	32"	10-18-25	640	480	1000	1160	101	760x640 x1430	113
IS 50 Idra	560/0,75	55	520	380	440	6'	75"	32"	10-18-25	730	550	1130	1250	145	760x640 x1430	160
	Potencia Potência Мощность 功率	Capacidad cilindro Cylinder capacity Емкость цилиндра 筒容積	Longitud cilindro Comprimento cilindro Длина цилиндра 筒長度	Diametro cilindro Diametro cilindro Диаметр цилиндра 筒直徑	Travecto pistón Curso pistão Шаг поршня 活塞行程	Velocidad min. vaciado Velocidade min. esvaziamento Мин. скорость опорожнения 最小推送速度	Velocidad max. vaciado Velocidade max. esvaziamento Мак. скорость опорожнения 最大推送速度	Velocidad regreso pistón Velocidade retorno pistão Скорость возврата поршня 活塞回路速度	Embutos en dotación ø int. ø Funis em dotação Внутр. ø прилагаемых воронок 直径不同的系列漏斗	A	B	C	D	Peso neto Peso líquido Вес нетто 淨重	Dimensiones embalaje Dimensões embalagem Размеры упаковки 包裝尺寸	Peso bruto Peso bruto Вес брутто 毛重



SO ALLUMINIO

segaossa bone saws

- Macchine dalla linea semplice e robusta, sicure e facili all'uso.
- Struttura autoportante realizzata in fusione di alluminio anodizzato, brillante, igienico e anticorrosivo.
- Complete di piano, spingicarne e porzionatrice in acciaio inox AISI 304.
- Comandi 24V con micro di sicurezza su porta, centralina di controllo ridondante e freno motore (CE).
- Massima semplicità e precisione nella regolazione sia orizzontale che verticale della puleggia superiore.
- Massima aderenza della lama alla puleggia grazie alla lavorazione semicurva delle pulegge e ad una perfetta regolazione.
- Cuscinetti ermetici su puleggia superiore.
- Pulizia facilitata grazie a 2 particolari accorgimenti di costruzione:
 - Tutte le parti elettriche sono protette in grado IP x5 o superiore.
 - Semplicemente svitando due manopole è possibile asportare lama, puleggia superiore e supporto della puleggia, si presenta così una superficie priva di ingombri.
- Potenti motori asincroni e ventilati a 4 poli protetti con paraolio di tenuta.
- Utilizzano lame temperate da 16 mm per tagli di ossa, congelato e fresco.

- *Simple and sturdy machines that are safe and easy to use.*
- *Stand-alone structure made out of cast anodized aluminium, shiny, hygienic and rustproof.*
- *Features a counter, meat pusher and serving slicer in stainless steel AISI 304.*
- *24V controls with safety micro-switch on door, redundant ECU and motor brake (EC).*
- *Utmost simplicity and accuracy when horizontally and vertically adjusting the upper pulley.*
- *Maximum blade adhesion to the pulley, thanks to the semi-curved shape of the pulleys and ideal adjustment.*
- *Airtight bearings on upper pulley.*
- *Smooth cleaning thanks to 2 special manufacturing details:*
 - *All the electrical parts are protected IP x5 or higher.*
 - *By simply unscrewing two knobs, you can remove the blade, upper pulley and its support, thereby making for a surface void of any encumbrance.*
- *Powerful asynchronous and ventilated 4-pole motors protected by sealing oil sump.*
- *The machines use tempered 16 mm blades to shred bone, frozen or fresh.*



SO 1650 -1840 F3

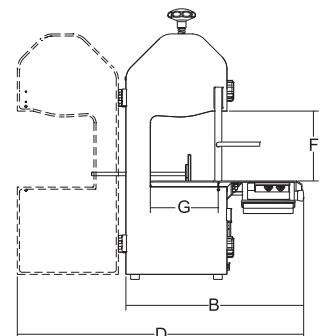
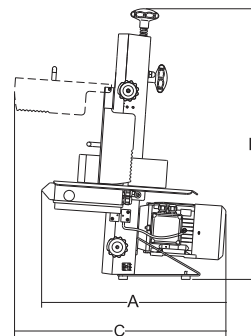

	Lunghezza nastro Blade length Bandsaeblänge Longueur lame	Motore Motor Motor Moteur	Puleggia Pulley Riemenscheibe Poulie	Sup. di lavoro Working surface Arbeitsfläch Surface de travail	A	B	C	D	E	F	G	Peso netto Net weight Nettogewicht Poids net	Dimensioni imballo Shipping Verpack abmessungen Dim. emballage	Peso lordo Gross weight Bruttogewicht Poids brut
	mm	Hp/r.p.m.	mm	mm	mm	mm	mm	mm	mm	mm	mm	Kg	mm	kg
SO 1550 F3	1550	1ph 1,5/1400 - 3ph 2/1400	210	400x420	530	510	606	822	778	215	195	32	720x570x1200	44
SO 1650 F3	1650	1ph 1,5/1400 - 3ph 2/1400	210	430x475	530	600	640	950	915	250	200	39	720x570x1200	51
SO 1840 F3	1840	1ph 1,5/1400 - 3ph 2/1400	250	430x475	530	600	640	950	915	250	240	40	720x570x1200	52



SO 1650 F3



SO 1840 F3





SO BREMEN

segaossa bone saws



SO 1650 BREMEN

- Macchina dalla linea elegante sicura e facile all'uso.
- Struttura autoportante realizzata in fusione di alluminio anodizzato.
- Carenatura motore, sportello e piano di lavoro in acciaio inox AISI 304.
- Completo di spingitore e porzionatrice.
- Puleggia superiore autotensionante con cuscinetti protetti ermeticamente.
- Comandi 24V con micro di sicurezza su porta, centralina di controllo ridondante e freno motore (CE).
- Massima semplicità e precisione nella regolazione della puleggia, sia in altezza che in inclinazione orizzontale e verticale, che permette la più affidabile aderenza della lama.
- Pulizia facilitata grazie alla superficie interna liscia e anodizzata.
- Potenti motori asincroni e ventilati a 4 poli protetti con paraolio di tenuta.
- Utilizzano lame temperate da 20 mm per taglio di ossa, congelato e fresco.

- *Elegant machine, safe and easy to use.*
- *Stand-alone structure made out of cast anodized aluminium.*
- *Motor covering, door and work counter in stainless steel AISI 304.*
- *Features a pusher and serving slicer.*
- *Self-tensioning upper pulley with hermetically guarded bearings.*
- *24V controls with safety micro-switch on door, redundant ECU and motor brake (EC).*
- *Maximum reliability and accuracy when adjusting the pulley, whether its height or horizontal and vertical tilt, which makes for improved blade adhesion.*
- *Smooth cleaning thanks to the polished and anodized inner surface.*
- *Powerful asynchronous and ventilated 4-pole motors protected by sealing oil sump.*
- *The machines use tempered 20-mm blades to shred bone, frozen or fresh.*

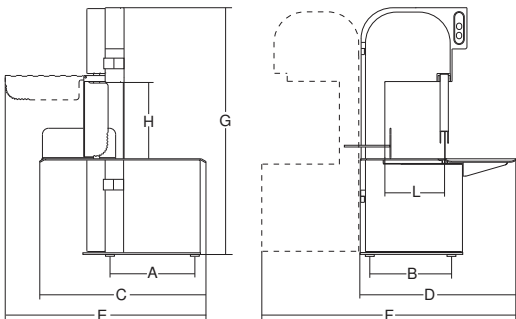

Lunghezza nastro
Blade length
Bandsaegellänge
Longueur lame

Motore
Motor
Moteur

Puleggia
Pulley
Poulie

Sup. di lavoro
Working surface
Arbeitsfläch
Surface de travail

A B C D E F G H L

Peso netto
Net weight
Nettogewicht
Poids net

Dimensioni imballo
Shipping
Verpack abmessungen
Dim. emballage

Peso lordo
Gross weight
Bruttogewicht
Poids brut

	mm	Hp/r.p.m.	mm	mm	mm	mm	mm	mm	mm	mm	mm	mm	mm	Kg	mm	kg
SO 1650 Bremen	1650	1ph 1,5/1400 3ph 2/1400	210	400x500	320	300	500	490	630	810	790	250	200	43,5	720x570x1140	55

Longitud cimita
Comprimento lâmina
Длина лезвия
刀片长度

Motor
Motor
Двигатель
电机

Polea
Polia
Шкива
滑轮

Sup. de trabajo
Sup. Trabalho
Рабочая поверхность
加工表面

A B C D E F G H L

Peso neto
Peso líquido
Вес нето
净重

Dimensiones embalaje
Dimensões embalagem
Размеры упаковки
包装尺寸

Peso bruto
Peso bruto
Вес брутто
毛重



SO BREMEN BASIC





SO INOX

segaossa bone saws

- Costruzione in acciaio inox AISI 304.
- Cassetto raccogliresti interbloccato e accessibile dall'esterno (non su mod. Start).
- Sportello facilmente rimovibile per agevolare la pulizia (non su mod. Start).
- Pulegge calibrate costruite in alluminio brillantato.
- Cuscinetti ermetici su puleggia superiore.
- Potenti motori asincroni e ventilati protetti con paraolio di tenuta.
- Comandi 24V con micro di sicurezza su porta e cassetto, centralina di controllo ridondante e freno motore (CE).
- Rapido sblocco puleggia superiore agevola la pulizia e il cambio lama.
- Raschiatori facilmente rimovibili e sostituibili.
- Potenti motori a 6 e 8 poli sviluppano grande forza con poco assorbimento (SO2400 e SO3100)
- Motori monofase con protezione termica di serie.
- Lavabili con spruzzo d'acqua (no alta pressione).
- Comandi in acciaio inox IP 67.
- Utilizzano lame temperate da 16 mm per taglio di ossa, congelato e fresco.

Opzioni:

- Carrello scorrevole (SO 2020-2400-3100).
- Motori veloci per taglio specifico di congelato.
- Puleggia SO1650 inox AISI 304.
- Puleggia SO2400 con bordatura in acciaio inox AISI 304.

- *Made out of stainless steel AISI 304.*
- *Interlocked bone chip tray accessible from outside (not on mod. Start).*
- *The door can be easily removed for smoother cleaning tasks (not on mod. Start).*
- *Calibrated pulleys built out of polished aluminium.*
- *Airtight bearings on upper pulley.*
- *Powerful asynchronous and ventilated motors protected by sealing oil sump.*
- *24V controls with safety micro-switch on door and tray, redundant ECU and motor brake (EC).*
- *Quick upper pulley releasing mechanism that makes it easier to clean and change the blade.*
- *Easily removable and replaceable scrapers.*
- *Powerful 6 or 8 pole motors provide great power with little absorption (SO2400 and SO3100)*
- *Single-phase motors with heat guard (standard feature).*
- *Can be cleaned with a water spray (no high pressure).*
- *Controls in stainless steel class IP 67.*
- *The machines use tempered 16 mm blades to shred bone, frozen or fresh.*

Optional accessories:

- *Sliding trolley (on SO 2020-2400-3100).*
- *Fast motors to specifically cut frozen products.*
- *SO1650 pulley in stainless steel AISI 304.*
- *SO2400 pulley with lining in stainless steel AISI 304.*



YouTube



SO 3100 INOX



SO 1650-1840 START

SO 2020 INOX DA PAVIMENTO

SO 2400 INOX



1. Cassetto raccolta scarti facilmente estraibile per la pulizia
Removable wastage tray for easy cleaning.



2. Raschiatori lama in materiale plastico alimentare ad innesto rapido. Flangia in materiale plastico alimentare nero a tenuta stagna per protezione motore.
Alimentary plastic blade scraper in quick to insert. Watertight black plastic flange to protect the motor.



3. Pulegge superiori ermetiche
Hermetic upper pulleys



4. Piano scorrevole opzionale
Optional sliding table



5. Piano scorrevole opzionale ribaltabile
Optional sliding table folding



SO 2400 INOX SX

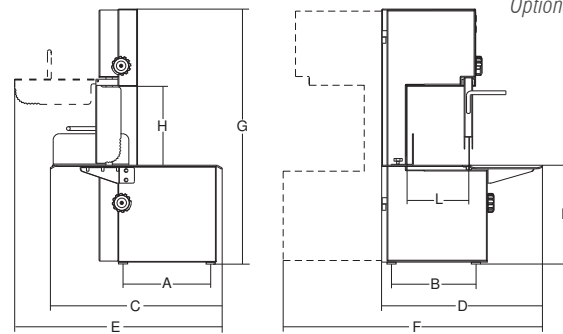

Lunghezza nastro
Blade length
Bandsserlänge
Longueur lame

Motore
Motor
Motor
Moteur

Puleggia
Pulley
Riemenscheibe
Poulie

Sup. di lavoro
Working surface
Arbeits-tisch
Surface de travail

A B C D E F G H L M

Peso netto
Net weight
Nettogewicht
Poids net

Dimensioni imballo
Shipping
Verpack abmessungen
Dim. emballage

Peso lordo
Gross weight
Bruttogewicht
Poids brut

	mm	Hp/r.p.m.	mm	mm	mm	mm	mm	mm	mm	mm	mm	mm	mm	mm	Kg	mm	kg
SO 1650 INOX START	1650	1,5/1400	210	400x450	315	314	535	520	640	862	815	252	197	320	46	570x720x1020	58
SO 1840 INOX START	1840	1,5/1400	250	440x450	315	334	537	560	640	923	843	252	237	320	51	570x720x1020	63
SO 1650 INOX	1650	1,5/1400	210	430x545	342	296	545	510	658	840	816	250	197	320	47	570x720x1020	59
SO 2020 INOX	2020	1,5/1400	250	480x600	253	346	568	560	710	930	1030	290	236	363	61	760x640x1430	73
SO 2020 INOX da pavimento	2020	1,5/1400	250	480x600	467	411	568	603	710	930	1650	290	236	980	70	760x640x1750	82
SO 2400 INOX	2400	2,5/900	300	510x710	444	524	715	750	840	1170	1670	350	287	897	100	1050x950x1960	125
SO 3100 INOX	3100	2,7/700	400	795x810	444	624	840	966	950	1485	1900	420	388	947	170	1050x950x1960	195

Longitud.cinta
Comprimento lamina
Длина лезвия
刀片长度

Motore
Motor
Двигатель
电机

Puleggia
Polia
Шкив
滑輪

Sup. de trabajo
Sup. Trabalho
Рабочая поверхность
加工表面

A B C D E F G H L M

Peso neto
Peso líquido
Вес нетто
淨重

Dimensiones embalaje
Dimensões embalagem
Размеры упаковки
包裝尺寸

Peso bruto
Peso brutto
Вес брутто
毛重



6. Tensionamento lama automatico
Automatic blade tensioning



SO 1650 INOX

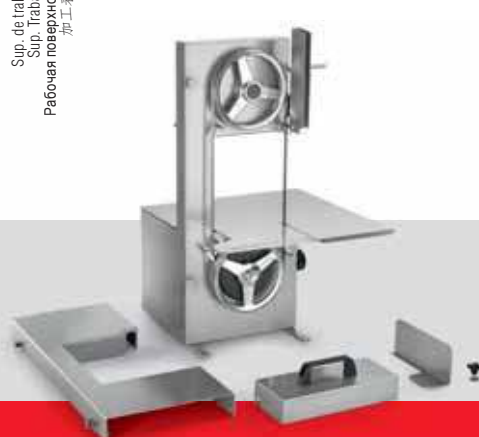



STERILIZZATO RI ELETTRICO E A LIQUIDO

sterilizzatori sterilizers

STERILIZZATORE A LIQUIDO:

adatti per il magazzino di ogni tipo di coltello, promuovono un'azione disinfettante per mezzo del liquido TEGO SI. Realizzato in acciaio inox e coperchio in polietilene HD bianco.

STERILIZZATORE ELETTRICO:

è dotato di attacchi per acqua in entrata e in uscita, con rubinetto di regolazione e scarico per evitare qualsiasi fuoriuscita del liquido. Temperatura a regolazione costante automatica a 90°C.

THE LIQUID STERILIZER:

is suitable for the storage of any kind of knives which are disinfected by means of TEGO SI liquid. Stainless steel body and HD polyethylene cover.

THE ELECTRIC STERILIZER:

is fit with water inlet and outlet connections which are regulated by 2 cocks to avoid any spill. Automatic temperature regulation at 90°C.



STERILIZZATORE ELETTRICO

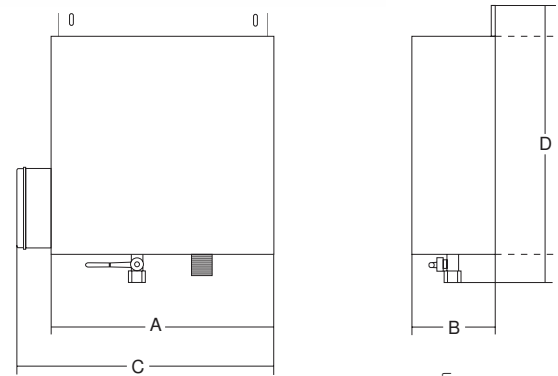

	Potenza Power Spannung Puissance	Alimentazione Power source Betriebspannung Alimentation	Termostato Thermostat Thermostat	Longhezza max lama coltello Max length of the blade of the knife Max Länge der Messerklinge Longueur max lame couteaux	A	B	C	D	Peso netto Net weight Nettogewicht Poids net	Dimensioni imballo Shipping Verpack. abmessungen Dim. emballage	Peso lordo Gross weight Bruttogewicht Poids brut
	Watt		°C	mm	mm	mm	mm	mm	Kg	mm	kg
Sterilizz. a liquido	-	-	-	320	400	135	-	35+360	5	420x510x150	6
Sterilizz. Elettrico coibentato	1500	230V/50Hz	0 ÷ 110	270	310	140	390	35+395+70	6,5	420x510x150	7,5
	Potencia Potencia Мощность 功率	Alimentación Alimentação Электропитание 电源	Termostato Thermostat Термостат 恒温器	Longitud max. hoja cuchillo Comprimento max. Lâmina da faca Макс. длина лезвия ножа 刀片最大长度	A	B	C	D	Peso netto Peso líquido Вес нетто 淨重	Dimensiones embalaje Dimensões embalagem Размеры упаковки 包裝尺寸	Peso bruto Peso bruto Вес брутто 毛重



STERILIZZATORE A LIQUIDO

STERILIZZATORI UV



sterilizzatori sterilizers



STERILIZZATORE UV 24 W

- Costruiti interamente in acciaio inox AISI 430.
- Porta in plexiglass fumè che chiude perfettamente la camera.
- Portacoltelli in plexiglass trasparente totalmente estraibile per una migliore pulizia e consente di sterilizzare i coltelli senza doverli girare
- mod. 24W con esclusiva vaschetta di raccolta gocce, incorporata con il portacoltelli.
- Lampade UVC ai vapori di mercurio con protezione in rete metallica
- Microinterruttore di sicurezza che spegne le lampade all'apertura della porta e viceversa alla chiusura.
- Particolare lampada di cortesia per il mod. 24W, che si accende solo se l'interruttore è in posizione "ON" e il timer a "0".
- Made from AISI430 stainless steel.
- Chamber is closed by a smoked plexiglass door.
- Removable see-through plexiglass knives holder makes sanitation easier and allows sterilization without having to rotate the knives.
- Knives holder with built in drops collecting tray (only on 24W version).
- Mercury vapour lamp UVC with wire screen protection.
- A safety microswitch switches the lamps on when the door is opened and switches them off when it is closed.
- The curtesy lamp, on 24W model, turns on only when the switch is "on" and the timer is at "0".

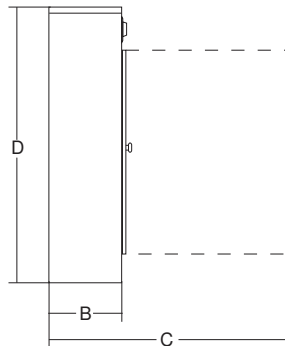
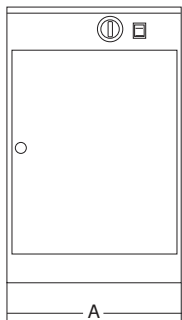

1. Portacoltelli asportabile su mod. 24 W
Knife storage unit removable for mod. 24 W

Q.tà lampade e potenza
Nr. of lamps and power
Nr. Lampen und Spannung
Nr. Lampes et puissance

Alimentazione
Power source
Betriebsspannung
Alimentation

Absorbimento
Absorption
Leistungsaufnahme
Puissance absorbée

Timer
Timer
Schaltuhr
Timer

Capienza coltelli
Knives capacity
Messer kapazität
Capacité couteaux

Lunghezza max lama coltello
Max length of the blade of the knife
Max. Länge der Messerklinge
Longueur max lame couteau

A B C D
Peso netto
Net weight
Nettogewicht
Poids net
Dimensioni imballo
Shipping
Verpack abmessungen
Dim. emballage

Peso lordo
Gross weight
Bruttogewicht
Poids brut

	Watt		min.	n.	mm	mm	mm	mm	mm	Kg	mm	kg	
Steril. UV 16W	n. 2 x 8	230V/50Hz	70 watt ~0,3A	0=120	15	310	400	140	520	620	9	470x250x700	11
Steril. UV 16W Napoli	n. 2 x 8	230V/50Hz	70 watt ~0,3A	0=120	15	450	400	140	520	760	10	470x250x820	12
Steril. UV 24W	n. 3 x 8	230V/50Hz	100 watt ~0,5A	0=120	20	290	400	300	690	620	14,5	470x400x700	16,5

C dad de lamparas y potencia
Quant. lampadas e potencia
Kon-vo lamp i ih moloshch
灯的數量及功率

Alimentación
Alimentação
Электропитание
電源

Absorción
Absorção
吸收率

Temporizador
Timer
タイマー
定时器

Capacidad de cuchillos
Capacidade facas
Кон-во ножей
刀數量

Longitud max. hoja cuchillo
Comprimento máx. Lâmina da faca
Макс. длина лезвия ножа
刀片最大長度

A B C D
Peso neto
Peso líquido
Вес нетто
淨重

Dimensiones embalaje
Dimensões embalagem
Размеры упаковки
包裝尺寸

Peso bruto
Peso bruto
Вес брутто
毛重



STERILIZZATORE UV NAPOLI 16 W



STERILIZZATORE UV 16 W



SA

hamburgatrici hamburger presses

- Hamburgatrici caratterizzate da una forma arrotondata semplice e compatta.
- Realizzate in lega di alluminio anodizzato.
- Contenitore porta cellophane incorporato pronto per l'uso.
- Piedini in gomma.

- Simple and compact patty press with rounded design.
- Made from anodized aluminium alloy.
- Built-in sheets holder.
- Rubber feet.



SA 150-180

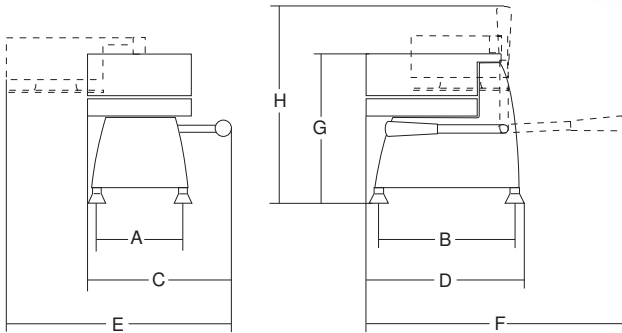

Diametro stampo
Diameter mould
Durchmesser form
Diamètre étampe

	A	B	C	D	E	F	G	H	Peso netto Net weight Nettogewicht Poids net	Dimensioni imballo Shipping Verpack. abmessungen Dim. emballage	Peso lordo Gross weight Brutogewicht Poids brut	
mm	mm	mm	mm	mm	mm	mm	mm	mm	Kg	mm	kg	
SA 100	100	140	230	255	270	310	380	260	320	4,5	450x370x350	5,5
SA 110	110	140	230	255	270	310	380	260	320	4,7	450x370x350	5,7
SA 130	130	140	250	260	310	360	460	275	360	6	450x370x350	7
SA 150	150	140	260	260	330	380	460	275	360	6,5	450x370x350	7,5
SA 180	180	140	260	265	330	430	500	275	360	7	450x370x350	8

Díametro molde
Díametro molde
Диаметр утравки
磨其直径

A	B	C	D	E	F	G	H	Peso netto Peso líquido Бес нетто 淨重	Dimensiones embalaje Dimensões embalagem Размеры упаковки 包裝尺寸	Peso bruto Peso bruto Бесчутто 毛重
---	---	---	---	---	---	---	---	---	---	--



SA 130



SA 100 - 110



DRAKE

inteneritrice bistecche - taglia strisce steak tenderizer - meat strip cutter



Optional

- Macchina inteneritrice e taglia strisce per carni e pesce.
 - Realizzata in acciaio inox AISI 304.
 - Ampia e pratica introduzione prodotto.
 - Coperchio facilmente rimovibile per le operazioni di pulizia.
 - Facile rimozione e sostituzione del gruppo lame.
 - Rulli lame facilmente smontabili per una pulizia più approfondita.
 - Doppio sistema di riduzione con cinghia e scatola ad ingranaggi in bagno d'olio.
- Steak and fish tenderizing and stripes cutting machine.
 - Stainless steel 304 construction.
 - Wide feeding income.
 - Easily removable cover for cleaning purposes.
 - Blade assembly easily removable and changeable.
 - Blade drums easily detachable for a deeper sanitification.
 - Double reducer system with final oil bath gear box.



1. Gruppo lame inteneritrice con 96 lame
Tenderizing blade assembly with 96 blades



2. Gruppo lame taglio:
da 10 mm con 48 lame
da 15 mm con 32 lame
Cutting blade assembly:
10 mm with 48 blades
15 mm with 32 blades

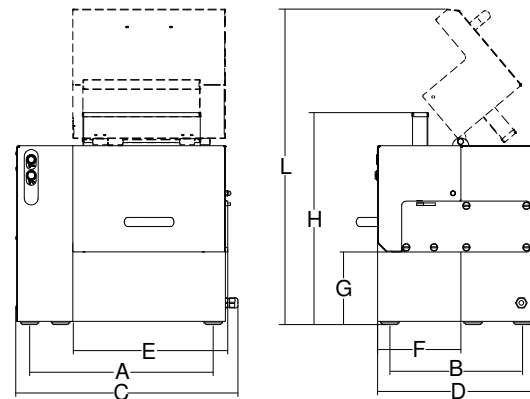

	Potenza Power Spannung Puissance	Alimentazione Power source Betriebsspannung Alimentation	Giri rulli/lame Revolutions rollers/blades Umdrehungen Walzen / Messer Révolutions rouleaux / lames	Lunghezza rulli Rollers width Breitewälzen Largeur rouleaux	Dimensioni bocca di carico Dim. loading hopper Admessungen Beladetrichter Dim. trémie de chargement	A	B	C	D	E	F	G	H	L	Peso netto Net weight Nettogewicht Poids net	Dimensioni imballo Shipping Verpack. abmessungen Dim. emballage	Peso lordo Gross weight Bruttogewicht Poids brut
	watt/HP		r.p.m.	mm	mm	mm	mm	mm	mm	mm	mm	mm	mm	mm	Kg	mm	kg
Drake	370/0,50	230V/50Hz	110	250	30x250	397	287	480	390	330	180	157	460	685	31	720x570x800	43

	Potencia Potência Мощность 功率	Alimentación Alimentação Электропитание 电源	Giro rodillos/cuchillas Giros rolos / lâminas Обороты валков/ножей 滚轴/滚刀转速	Ancho rodillos Largura rolos Ширина валков 滚轴宽度	Dimensiones tova de carga Dimensões trenaína de carga Размеры загруз. воронка 进料口尺寸	A	B	C	D	E	F	G	H	L	Peso neto Peso líquido Бес нетто 净重	Dimensiones embalaje Dimensões embalagem Размеры упаковки 包装尺寸	Peso bruto Peso bruto Бес брутто 毛重
--	--	---	---	--	--	---	---	---	---	---	---	---	---	---	--	---	--



Optional





T- REX

inteneritrici tenderizers



T-Rex manuale

- Tutti i particolari solo in acciaio inox.
- Molle di ritorno totalmente protette da sporco e liquidi.
- Facile smontaggio e pulizia del gruppo coltelli.
- Piano in polietilene con movimento libero.
- Scorrimento su boccole in tecnopolimero.
- Scorrimento su aste inox 304 rettificate.

T-Rex Automec

- Pacco lame 213 x 80 x h. 62 mm.
- Motorizzazione con sistema a biella.
- Piano mobile a mezzo leva esterna alla protezione.
- Protezione interbloccata rimovibile.
- Scorrimento su boccole in tecnopolimero.
- Totalmente inox.
- Facile smontaggio lame.
- Lame sostituibili anche singolarmente.



T- REX



T- REX AUTOMEC

T-Rex manual

- *Stainless steel body and details.*
- *Totally covered springs protected from dirt and liquids.*
- *Quick blade disassembling for easy cleaning.*
- *Mobile polyethylene cutting board.*
- *Sliding on tecnopolymer bushes.*
- *Sliding on s/s aisi 304 grinded shafts*

T-Rex Automec

- *Dimensions of the blades set: 213x80xh.62.*
- *Drive with connecting rod system.*
- *Movable cutting board by an external lever.*
- *Removable interlocking system.*
- *Sliding on tecnopolymer bushes.*
- *Completely made from stainless steel.*
- *Easy removable blades.*
- *Individually replaceable blades .*

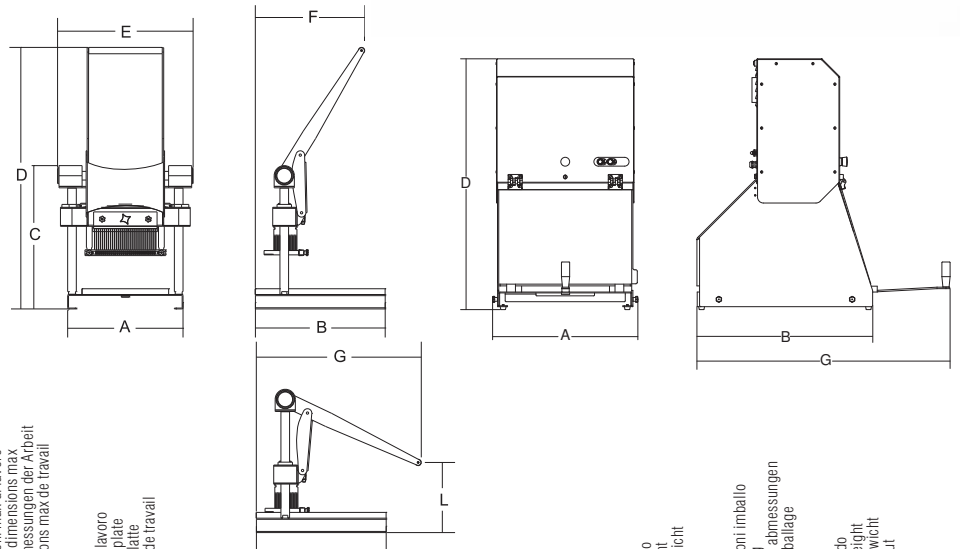

Potenza
Power
Spaaning
Puissance

Alimentazione
Power source
Betriebsspannung
Alimentation

Dimensioni max di lavoro
Working dimensions max
Max abmessungen der Arbeit
Dimensions max de travail

Piano di lavoro
Working plate
Arbeitsplatte
Surface de travail

Lame
Blades
Klingen
Lames

A B C D E F G L

Peso netto
Net weight
Nettogewicht
Poids net

Dimensioni imballo
Shipping
Verpack. abmessungen
Dim. emballage

Peso lordo
Gross weight
Bruttogewicht
Poids brut

	watt/HP		mm	mm	n.	mm	mm	mm	mm	mm	mm	mm	Kg	mm	kg	
T-Rex	-	-	216x280x100	300x450	32	400	450	497	907	470	378	572	243	25	720x770x570	35
T-Rex-AUTOMEC	550 / 0,75	230V/50Hz	216x280x100	300x430	32	496	601	-	867	-	-	865	-	63	670x600x1200	75

Potencia
Potência
Мощность
功率

Alimentación
Alimentação
Электропитание
電源

Dimensiones máx de trabajo
Dimensões máx. de trabalho
Рабочие размеры макс
工作尺寸最大

Piano de trabajo
Plano de trabalho
Рабочая поверхность
工作表面

Cuchillas
Lâminas
Клинья
刀片

A B C D E F G L

Peso neto
Peso líquido
Вес нетто
淨重

Dimensiones embalaje
Dimensões embalagem
Размеры упаковки
包裝尺寸

Peso bruto
Peso bruto
Вес брутто
毛重



1. Facilmente rimovibili
Easy removable



2. Piano in polietilene con movimento libero
Mobile polyethylene cutting board

CEPPI - TAVOLI - PIANI

chopping blocks-working tables-working surfaces



1. Tavoli
Tables

- Adatti per la lavorazione di carne, pesce, verdure e di tutti gli alimenti in genere, sono indispensabili nelle macellerie, nelle pescherie, nei salumifici, nelle industrie alimentari e nelle cucine di alberghi e ristoranti.
- Piani in polietilene HD non assorbono, sono antibatterici e facilmente lavabili.
- Non deteriorano il filo dei coltelli.
- Tavoli con strutture in tubo di alluminio anodizzato mm 50x50 rinforzate internamente con acciaio zincato per una maggiore stabilità e robustezza.
- Disponibili sia nelle versioni standard che su misura e con sottopiani opzionali, sono facilmente montabili e smontabili per un minimo ingombro di spedizione.

- Suitable for processing meat, fish, vegetables and any kind of products. Cutting boards are essential in butchers', fishmongers', meat processing factories, food processing industries, hotel and restaurant kitchens.
- HD polyethylene cutting boards are non-absorbent, antibacterial and easy to clean.
- Knives are not damaged.
- Working table frame is made from anodized aluminium tubes (50X50 mm) reinforced with galvanized steel for a better stability and sturdiness.
- Available both standard or cut to size, with or without base shelf.
- Tables can be easily assembled and disassembled for minimum shipping dimensions.



2. CEPPI IN POLIETILENE
Polyethylene chopping blocks



- 4. Pesce - Fish
- 5. Pollo - Chicken
- 6. Verdure - Vegetables
- 7. Carne - Meat
- 8. Carne di cavallo - Horsemeat

3. PIANI IN POLIETILENE CON LISTELLO
Polyethylene sheet

IMBALLAGGIO | PACKAGING MACHINES

Prolungare la vita di un prodotto, migliorarne la presentazione, conservabilità e trasportabilità. Questi gli obiettivi delle macchine sottovuoto e imballaggio di Sirman nel rispetto delle caratteristiche intrinseche ai prodotti trattati, per poterne conservare prelibatezza e sapori. Tutte le macchine sono studiate per garantire prestazioni superiori con la massima ergonomia, semplicità d'uso e sanificazione.

Extending a product's shelf life, improving presentation, storability and transportability without altering the inherent characteristics of the treated products, preserving delicacy and flavour.

These are the goals of Sirman packing and vacuum packing machines.

All machines are designed to deliver superior performance with improved ergonomics, ease of use and sanitation.





SIG IX M20

sigilla vaschette thermosealers

- Pratica e robusta sigillavaschette manuale
- Struttura in acciaio inox AISI 304
- Controllo elettronico con temperatura e preriscaldamento
- Conteggio vaschette
- Tempo di saldatura 4 secondi
- Massima dimensione vaschetta mm 260x190
- Stampi custom a disegno
- Piastra sigillante in alluminio teflonato
- Massima larghezza film mm 200.

Opzionali:

- Vaschette disponibili
mm 137x95 h.63
mm 190x137 h.72
mm 230x190 h.65
mm 260x190 h.65
- Stampi relativi alle vaschette disponibili.

- A practical and robust manual tray sealer
- AISI 304 stainless steel body
- Electronic controller with temperature and preheating controls
- Tray count
- Sealing time: 4 seconds
- Maximum tray size: 260x190 mm
- Custom dies made to drawings
- Teflon coated aluminium sealing plate
- Maximum film width: 200 mm

Options:

- Standard trays
137x95, h.63 mm
190x137, h.72 mm
230x190, h.65 mm
260x190, h.65 mm
- Dies for standard tray sizes

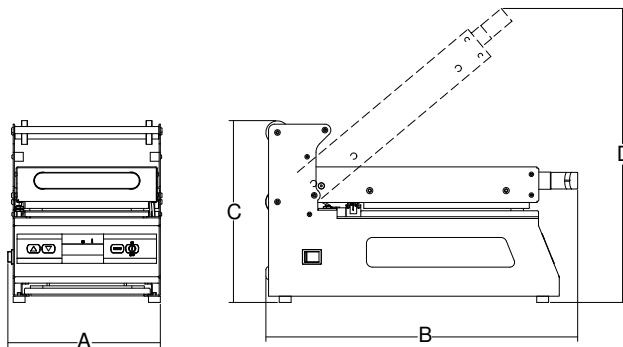

	Potenza Power Spannung Puissance	Alimentazione Power source Betriebsspannung Alimentation	Rotoli film Max. film roll Folienrollen max Max. bobine film	Dimensioni max vaschetta Tray max dimensions Tablets max Abmessungen Dimensions max plateau	A	B	C	D	Peso netto Net weight Nettogewicht Poids net	Dimensioni imballo Shipping Verpack. abmessungen Dim. emballage	Peso lordo Gross weight Bruttogewicht Poids brut
	watt		mm	mm	mm	mm	mm	mm	Kg	mm	kg
Sigix M20	900	230V/50Hz	200	260x190	257	525	306	496	18	620x380x400	22
	Potencia Potência Мощность	Alimentación Alimentação Электропитание 電源	Rollos película Bobina película 最大巻膜巻	Dimensiones máx bandeja Dimensões máx bandeja Лоток Макс размеры 最大托盤尺寸	A	B	C	D	Peso neto Peso líquido Вес нетто 淨重	Dimensiones embalaje Dimensões embalagem Размеры упаковки 包裝尺寸	Peso bruto Peso bruto Вес брутто 毛重





EASYVAC 25

sottovuoto vacuum packaging machines



- Macchina compatta e veloce, dedicata a piccole porzioni, ideale abbinamento a strumenti di cottura a bassa temperatura tipo Softcooker.
- Facile settaggio del tempo di vuoto e di saldatura.
- Barra saldante facilmente rimovibile.
- Pompa aspirazione Busch.
- Visualizzazione percentuale vuoto e tempo residuo.
- Memorizzazione ultima impostazione.
- Contacigli utilizzo totale.
- Preriscaldamento pompa e ciclo pulizia olio
- Messaggio cambio olio.
- Vuoto esterno a tempo.
- Sollevamento coperchio manuale.

- A compact and fast machine for small sized products, ideal combined with low temperature cooking instruments like the Softcooker.
- Easily settable vacuum and sealing time.
- Easily removable sealing bar.
- Busch suction pump.
- Display of vacuum percentage and time to countdown.
- Last setting can be saved in memory
- Cycle counter.
- Pump preheating and oil cleaning cycle
- Change oil message.
- Timed external vacuum.
- Manual cover lift.

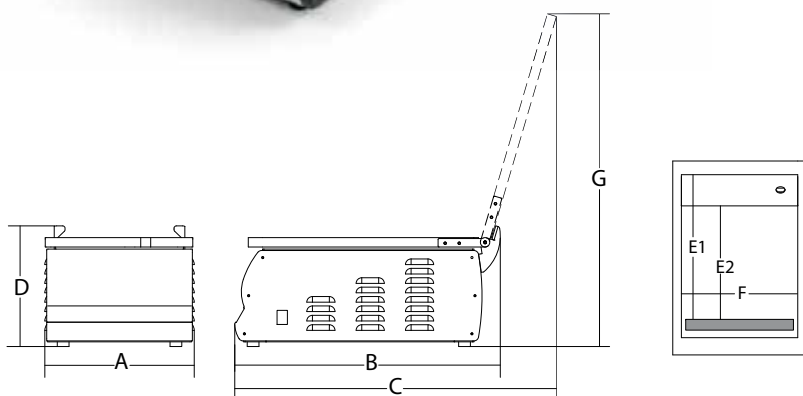

	Potenza Power Spannung Puissance	Alimentazione Power source Betriebsspannung Alimentation	Pompa del vuoto Vacuum pump Vakuumpumpe Pompe de vide	Barra saldante Sealing bar Schweißleiste Barre de soudre	Dimensioni camera Cavity dimensions Kammergrösse Dimensiones de la chambre	A	B	C	D	E1	E2	F	G	Peso netto Net weight Nettogewicht Poids net	Dimensioni imballo Shipping Verpack, abmessungen Dim. emballage	Peso lordo Gross weight Bruttogewicht Poids brut
	Kw		mc/h	mm	mm	mm	mm	mm	mm	mm	mm	mm	mm	Kg	mm	kg
Easyvac 25 BX	0,1	230V/50Hz	4	260	270x350 h.75	320	560	685	257	340	263	264	708	30	660x420x310	32
	Potencia Potência Мощность 功率	Alimentación Alimentação Электронпитание 電源	Bomba de vacío Bomba de vácuo Вакуумный насос 真空泵	Barra de sellado Barra de selagem Уплотнительная бара 密封条	Dimensiones de la cavidad Dimensões das cavidades Размеры полости 型腔尺寸	A	B	C	D	E1	E2	F	G	Peso netto Peso líquido Вес нетто 淨重	Dimensiones embalaje Dimensões embalagem Размеры упаковки 包裝尺寸	Peso bruto Peso bruto Вес брутто 毛重

1. Tubo per aspirazione esterna opzionale
Optional tube for external air extraction





W8 30-40-50-70

sottovuoto vacuum packaging machines



- Straordinario design riduce l'ingombro della macchina e migliora la praticità
- Campana a grande sviluppo di volume in plexiglass termoformato di grosso spessore sui mod. 50 e 70, ad iniezione sui mod. 30 e 40
- Barra saldante facilmente rimovibile
- Estrema facilità di pulizia grazie alla perfetta planarità del piano di appoggio prodotto.
- Sollevamento coperchio automatico a mezzo di pistoncini pneumatici.

Sistema di controllo elettronico con sensore di pressione:

- selezione 6 lingue
- impostazione tempo saldatura, vuoto e gas con scala 1/10 sec.
- visualizzazione percentuale vuoto e tempo residuo
- 10 programmi memorizzabili a piacere
- programma AA = vuoto automatico
- programma AL = vuoto automatico per liquidi
- programma XT = aspirazione esterna a tempo
- programma XA = aspirazione esterna automatica
- Percentuale vuoto automatico regolabile 50-100%
- Segnale di avviso sostituzione olio e filtro.
- Protezione termica pompa.
- Ciclo di preriscaldamento e pulizia olio.
- Contacigli totali.
- Contatore utilizzo pompa.
- Piano per buste con liquidi.
- Pompa aspirazione Bush.
- Piano posizionamento prodotto in acciaio inox AISI 304 spessore 5 mm.

Accessori opzionali:

- Impianto per gas inerte (MAP) e soft air.
- Stampante termica automatica per data, ora e dati confezionamento.
- Tubo per aspirazione esterna.
- Vasche GN per aspirazione esterna.
- Ripiano in plexiglass trasparente.



W8 40 BX
con gas inerte e soft air opzionali
with inert gas system and soft air optional

- *Exceptional design to reduce machine size and improve its practicality.*
- *Large and wide bell in thermoformed plexiglass on mod. 50 and 70, injection on mod. 30 and 40.*
- *Easily removable sealing bar.*
- *Extremely easy to clean thanks to a perfectly level product counter.*
- *Automatic cover lift operated by pneumatic pistons.*

Electronic control system featuring with pressure sensor:

- 6 selectable languages.
- Settable sealing, vacuum and gas time on a scale 1-10 sec.
- Display of vacuum percentage and time to countdown.
- 10 different settings savable to preference
- Setting AA = automatic vacuum

- *Setting AL = automatic vacuum for liquids*
- *Setting XT = timed external suction*
- *Setting XA = automatic external suction*
- *Adjustable automatic vacuum percentage: 50-100%.*
- *oil and filter change warning light.*
- *Thermal pump guard*
- *Oil preheat and cleaning cycle*
- *Total rev counter*
- *Pump meter*
- *Surface for liquid bags*
- *Bush suction pump.*
- *5 mm thick, AISI 304 stainless steel, easy to clean plain vacuum chamber.*

Optional accessories:

- *Inert gas system (MAP) and soft air*
- *Automatic thermal printer by date, time and packing specifications*
- *Hose for external suction*
- *GN tanks for external suction.*
- *Plexiglass support.*



W8 40 BX



W8 50 BX



W8 50 BX DB



W8 70 BX TB

1. Estrema facilità di pulizia
Easy cleaning

W8 30-40 Easy

- Facile settaggio del tempo di vuoto e di saldatura.
- Visualizzazione percentuale vuoto e tempo residuo.
- Memorizzazione ultima impostazione.
- Contacicli e contatore utilizzo pompa.
- Preriscaldamento pompa e ciclo pulizia olio.
- Messaggio cambio olio e filtro.
- Vuoto esterno a tempo.
- Non disponibile con stampante o Gas.
- Campane ad iniezione con grande sviluppo di volume.
- Sollevamento coperchio automatico a mezzo di pistoncini pneumatici.
- Barra saldante facilmente rimovibile.

W8 30-40 Easy

- *Easy vacuum and sealing time setting.*
- *Display of vacuum percentage and time to countdown.*
- *Last setting saved in memory.*
- *Rev counter and pump meter.*
- *Pump preheating and oil cleaning cycle.*
- *Oil and filter change message.*
- *Timed external vacuum.*
- *Not available with printer or Gas.*
- *Large injection bells.*
- *Automatic cover lift operated by pneumatic pistons.*
- *Easily removable sealing bar.*



W8 70 BX TB P



W8 30 EASY BX



W8 40 EASY BX



W8 40 EASY BX



2. Controllo elettronico semplice ed intuitivo
User-friendly, intuitive operation



3. Controllo elettronico mod. Easy semplice ed intuitivo
User-friendly, intuitive operation, for mod. Easy



4. Sistema sospensione coperchio ammortizzato
Cushion-hinged lid



5. Stampante integrata opzionale
Optional integrated printer



6. Barra saldante standard
Standard sealing bar



7. Doppia barra saldante W8 50 DB
Double sealing bar W8 50 DB



8. Tripla barra saldante W8 70 TB
Triple sealing bar W8 70 TB



9. Opzione gas inerte e soft air (escluse le Easy)
Inert gas system and soft air option (not available on Easy)



10. Piano per buste con liquidi di serie (escluso le W8 50 DB e le W8 70 TB)
Surface for liquid bags standard (not available for mod. W8 50 DB and W8 70 TB)



11. Cavalletto alluminio per W8 50 - opzionale con e senza ruote - mm 586x564 h.757
Aluminium table base for W8 50 - optional with and without wheels - mm 586x564 h.757





12. Tubo per aspirazione esterna opzionale
Optional tube for external air extraction



13. Contenitori GN 1/1 - 1/2 - 1/3 (h.100/150)
opzionale
GN trays 1/1 - 1/2 - 1/3 (h.100/150) optional



14. Ripiano in plexiglass opzionale
Optional plexiglass support



15. Facile manutenibilità
Easy access for service



Buste per sottovuoto lisce μm 70
Vacuum bags smooth μm 70

Buste per sottovuoto lisce μm 90
Vacuum bags smooth μm 90

Buste per sottovuoto goffrate μm 105
Vacuum bags embossed μm 105

Buste per cottura sottovuoto μm 90
Cooking vacuum bags μm 90

cm 20x30
cm 25x35
cm 30x40
cm 40x50

cm 17x25
cm 20x30
cm 25x35
cm 30x40
cm 35x45
cm 40x50

cm 20x30
cm 25x35
cm 30x40
cm 35x45
cm 40x50

cm 15x20
cm 20x30
cm 25x35
cm 30x40

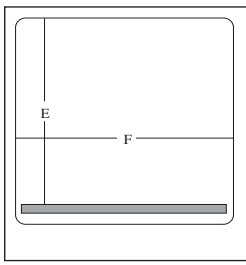

W8 30-40-50

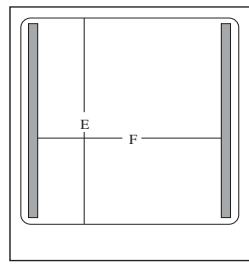

W8 50DB

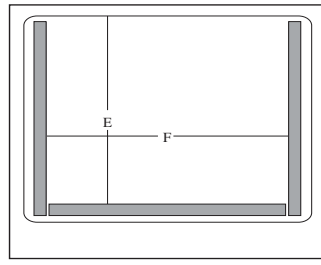

W8 70TB

IDENTIFICAZIONE MODELLI

- D = Pompa DVP
- B = Pompa Busch
- X = piano appoggio inox 5 mm
- 12 = pompa aspirazione 12 mc
- DB = doppia barra saldante
- TB = tripla barra saldante

MODELS IDENTIFICATION

- D = DVP suction pump
- B = Busch suction pump
- X = s/steel surface
- 12 = Pump out stantard 12 mc
- DB = Double sealing bar
- TB = Triple sealing bar

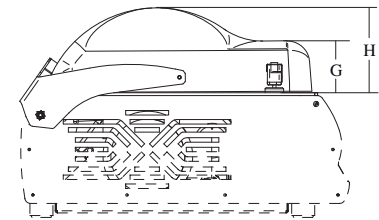
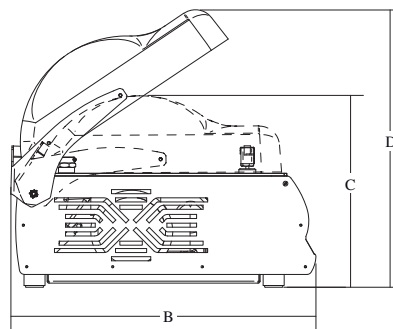
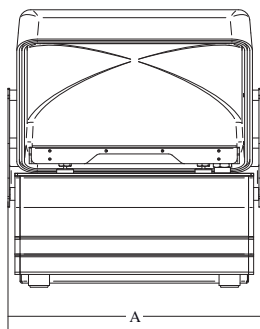

	Potenza Power Spannung Puissance	Alimentazione Power source Betriebsspannung Alimentation	Pompa del vuoto Vacuum pump Vacuum pumpe Pompe de vide	Barra saldante Sealing bar Schweißleiste Barre de souder	Dimensioni camera Cavity dimensions Kammergrösse Dimensiones de la chambre	A	B	C	D	E	F	G	H	Peso netto Net weight Nettogewicht Poids net	Dimensioni imballo Shipping Verpack abmessungen Dim. emballage	Peso lordo Gross weight Bruttogewicht Poids brut
	Kw	mc/h	mm	mm	mm	mm	mm	mm	mm	mm	mm	mm	mm	Kg	mm	kg
W8 30 Easy DX	0,35	230V/50Hz	8	310	340x360 h.160	402	525	408	587	334	340	95	170	38	720x570x770	48
W8 30 Easy BX	0,35	230V/50Hz	8	310	340x360 h.160	402	525	408	587	334	340	95	170	38	720x570x770	48
W8 30 Easy DX 12	0,45	230V/50Hz	12	310	340x360 h.160	402	525	408	587	334	340	95	170	38	720x570x770	48
W8 30 DX	0,35	230V/50Hz	8	310	340x360 h.160	402	525	408	587	334	340	95	170	38	720x570x770	48
W8 30 BX	0,35	230V/50Hz	8	310	340x360 h.160	402	525	408	587	334	340	95	170	38	720x570x770	48
W8 30 DX 12	0,45	230V/50Hz	12	310	340x360 h.160	402	525	408	587	334	340	95	170	38	720x570x770	48
W8 40 Easy DX 12	0,45	230V/50Hz	12	410	430x410 h.170	493	585	422	630	334	430	99	180	54	760x640x770	66
W8 40 Easy DX	0,75	230V/50Hz	21	410	430x410 h.170	493	585	422	630	334	430	99	180	56	760x640x770	66
W8 40 Easy BX	0,75	230V/50Hz	21	410	430x410 h.170	493	585	422	630	334	430	99	180	56	760x640x770	66
W8 40 DX	0,75	230V/50Hz	21	410	430x410 h.170	493	585	422	630	390	430	99	180	56	760x640x770	66
W8 40 BX	0,75	230V/50Hz	21	410	430x410 h.170	493	585	422	630	390	430	99	180	56	760x640x770	66
W8 50 DX	0,75	230V/50Hz	21	510	545x460 h.190	609	640	420	605	430	540	90	210	70	840x870x750	86
W8 50 BX	0,75	230V/50Hz	21	510	545x460 h.190	609	640	420	605	430	540	90	210	70	840x870x750	86
W8 50 DX DB	0,75	230V/50Hz	21	410x2	545x460 h.190	609	640	420	605	424	428	90	210	75	840x870x750	87
W8 50 BX DB	0,75	230V/50Hz	21	410x2	545x460 h.190	609	640	420	605	424	428	90	210	75	840x870x750	87
W8 70 DX 40 TB	1,1	400V/50Hz	40	640x1 / 410x2	780x490 h.190	877	630	513	747	424	660	95	200	115	1200x800x720	128
W8 70 BX 40 TB	1,1	400V/50Hz	40	640x1 / 410x2	780x490 h.190	877	630	513	747	424	660	95	200	115	1200x800x720	128
W8 70 DX 40 TB P	1,1	400V/50Hz	40	640x1 / 410x2	780x490 h.190	877	674	1134	1368	424	660	95	200	167	1200x800x1350	180
W8 70 BX 40 TB P	1,1	400V/50Hz	40	640x1 / 410x2	780x490 h.190	877	674	1134	1368	424	660	95	200	167	1200x800x1350	180

Potencia
Potencia
 Мощность

Alimentación
Alimentação
Электропитание
電源

Bomba de vacío
Bomba de vácuo
Вакуумный насос
真空泵

Barra de sellado
Barra de selagem
Уплотнительная бара
密封条

Dimensiones de la cavidad
Dimensões das cavidades
Размеры полости
腔尺寸

A

B

C

D

E

F

G

H

Peso netto
Peso líquido
Вес нето
淨重

Dimensiones embalaje
Dimensões embalagem
Размеры упаковки
包裝尺寸

Peso bruto
Peso bruto
Вес брутто
毛重



DISPENSER

dispenser shrink wrappers

- Ideati per il confezionamento di alimenti come carne, formaggio, pasta, frutta e verdura freschi; i dispenser offrono un servizio veloce e igienico nei supermercati, macellerie e gastronomie in genere, dove il commercio di prodotti freschi richiede un confezionamento giornaliero veloce e sicuro.
- Struttura in acciaio inox.
- Rulli e astine in alluminio anodizzato.
- Taglio del film per mezzo di un filo caldo a bassa tensione per i modelli 40M, 50M2 e 51M.
- Profilo teflonato per i modelli 50MBT e 51MB (non provoca fumo).
- *Designed for packing meat, cheese, pasta, fruits and vegetables; our wrapping machines offer a fast hygienic service for supermarkets, butcher's, delicatessens and wherever fresh products retail needs a quick and safe daily packaging.*
- *Stainless steel body.*
- *Anodized aluminium rollers and rods.*
- *Film cutting by means of a low-voltage heated wire (versions: 40M, 50M2 and 51M)*
- *50MBT0 and 51MB versions with teflon coated section. (do not smoke).*



51 M



1. Particolare filo caldo (1)
Heated cutting tread (1)



2. Profilo teflonato (2)
Teflon-coated section (2)

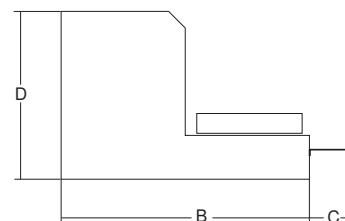
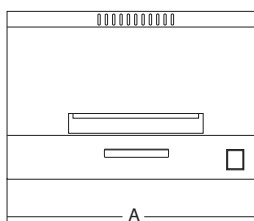

	Potenza Power Spannung Puissance	Alimentazione Power source Betriebsspannung Alimentation	Taglio film Film cutting Folienchnitt Coupe de la pellicule	Rotoli film Max. film roll Folienrollen max Max. bobine film	Piano riscaldante Heating surface Heizfläche Plateau chauffant	A	B	C	D	Peso netto Net weight Nettogewicht Poids net	Dimensioni imballo Shipping Verpack. abmes- surungen Dim. emballage	Peso lordo Gross weight Bruttogewicht Poids brut
	Watt	230V/50Hz	(1)	mm	mm	mm	mm	mm	mm	Kg	mm	kg
40M	115	230V/50Hz	(1)	400	290x165	465	500	125	290	12,5	580x600x370	14
50M2	115	230V/50Hz	(1)	500	290x165	590	540	125	290	14	650x580x370	15,5
50MBT	190	230V/50Hz	(2)	500	290x165	590	500	125	290	14	650x580x370	15,5
51M	115	230V/50Hz	(1)	500	300x175	590	720	130	185	14,5	780x670x270	16
51MB	190	230V/50Hz	(2)	500	300x175	590	720	130	185	14,5	780x670x270	16

Potencia
Potência
Мощность
功率

Alimentación
Alimentação
Электропитание
電源

Corte de película
Corte filme
Вырезывания пленки
薄膜切割

Rotulos película
Bobina película
Рулон пленки макс.
最大薄膜卷

Piano calentador
Plano de aquecido
Подогреваемая поверхность
加热表面

A B C D

Peso neto
Peso líquido
Вес нетто
淨重

Dimensiones embalaje
Dimensões embalagem
Размеры упаковки
包裝尺寸

Peso bruto
Peso bruto
Вес брутто
毛重



51 MB



50 M2



40 M

MACCHINE COTTURA

Indispensabili accessori e nuove tecnologie completano il catalogo Sirman di un pacchetto di macchine specifiche per la cottura.

Dalle insostituibili salamandre e pratici forni a convezione, fino alle tecnologie più evolute come induzione e cottura a bassa temperatura. Dove tradizione e innovazione trovano un perfetto connubio, a supporto di chef professionisti che pretendono sempre il massimo dalle proprie attrezzature.

COOKING MACHINES

Essential equipments and new technologies complete the Sirman catalogue with a range of machines specifically designed for cooking: from the unique salamanders and easy to use convection ovens to the most advanced technologies such as induction and low temperature cooking.

Here is a perfect match between tradition and innovation, supporting professional chefs who always require the highest performance from their equipments.





EASYSO FT

*sottovuoto e cottura a bassa temperatura
packaging machine and low temperature cooking*



Magnifico connubio tra macchina per il sottovuoto a campana e apparecchio cottura a bassa temperatura.

- Macchina sottovuoto compatta e veloce, dedicata a piccole porzioni
- Facile settaggio del tempo di vuoto e di saldatura.
- Barra saldante facilmente rimovibile.
- Pompa aspirazione a bagno d'olio.
- Visualizzazione percentuale vuoto e tempo residuo.
- Memorizzazione ultima impostazione.
- Contacicli e contatore utilizzo pompa.
- Periscaldamento pompa e ciclo pulizia olio
- Messaggio cambio olio.
- Vuoto esterno a tempo.
- Sollevamento coperchio manuale.
- Vasca in acciaio inox AISI 304.
- Apparecchio statico per la cottura a bassa temperatura.
- Potenti resistenze corazzate a contatto nel fondo della vasca.
- Vasca in acciaio inox AISI 304.
- Sistema elettronico di controllo della temperatura con visualizzazione di temperatura e tempo di esercizio.
- Stesso sistema di controllo del Softcooker con ΔT di 0,2°C:
 - 5 programmi memorizzabili.
 - Temperatura selezionabile in °C e °F.
 - Coperchio vasca fornito di serie.
- Allarme sonoro raggiunta temperatura.
- Allarme sonoro fine tempo cottura.



Fantastic combination of a chamber vacuum packing machine and a low temperature cooking device.

- Quick compact vacuum packing machine for small servings.
- Easily set vacuum and sealing times.
- Easily removable sealing bar.
- Oil bath suction pump.
- Display vacuum percentage and remaining time.
- Save last setting.
- Cycles counter and pump usage counter.
- Pump preheating and oil cleaning cycle.
- Oil change message.
- Timed external vacuum.
- Manual lid.
- Aisi 304 stainless steel tray.

- Static appliance for low temperature cooking.
- Powerful armoured contact heating elements in the bottom of the tank.
- Aisi 304 stainless steel tank.
- Electronic temperature control system with temperature and operating time display.
- Same control system of the Softcooker with ΔT of 0.2° C.
 - 5 programs that can be saved.
 - Temperature can be set in °C and °F.
 - Tank lid provided as standard equipment.
- Audible alarm when temperature reached.
- Audible alarm at end of cooking time.





1. Controllo elettronico semplice ed intuitivo
User-friendly, intuitive operation



2. Tubo per aspirazione esterna opzionale
Optional tube for external air extraction



3. Visualizzazione immediata di tutte le informazioni
The display shows immediately all available functions

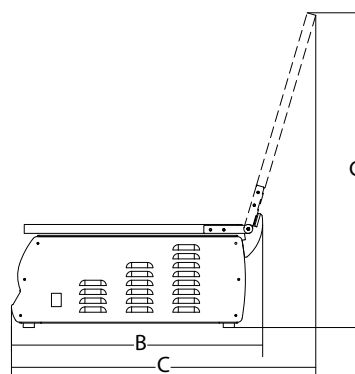
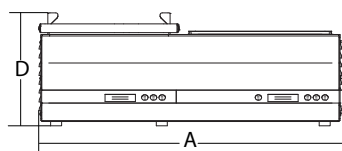
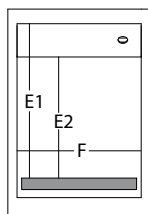

	Potenza Power Spannung Puissance	Alimentazione Power source Betriebspannung Alimentation	Pompa del vuoto Vacuum pump Vacuum pompe Pompe de vide	Barra saldante Sealing bar Schweißleiste Barre de souder	Dimensioni camera sottovuoto Vacuum cavity dimensions Abmessungen vom Vakuumraum Dimensions de la chambre de vide	Dimensioni vassica cottura Cooking tray dimensions Abmessungen vom Kochraum Dimensions chambre de cuisson	A	B	C	D	E1	E2	F	G	Peso netto Net weight Nettogewicht Poids net	Dimensioni imballo Shipping Verpack. abmessungen Dim. emballage	Peso lordo Gross weight Brutogewicht Poids brut
	watt		mc/h	mm	mm	mm	mm	mm	mm	mm	mm	mm	mm	mm	Kg	mm	kg
Easysoft	100+1.700	230V/50Hz	4	260	270x350 h.75	280x400 h.180	695	560	685	257	340	263	264	708	45	740x720x320	48

Potencia
Potência
Мощность
功率

Alimentação
Alimentação
Электропитание
电源

Bomba de vacío
Bomba de vacío
Вакуумный насос
真空泵

Barra de sellado
Barra de sellagem
Уплотнительная бара
密封条

Dimensiones de la cavidad de vacío
Dimensiones das cavidades vacuum
Размеры вакуумной полости
真空腔尺寸

Dimensiones de la cavidad de cocción
Dimensiones das cavidades de cozêdura
Размеры полости
烹饪腔尺寸

A

B

C

D

E1

E2

F

G

Peso neto
Peso líquido
Вес нетто
净重

Dimensiones embalaje
Dimensiones embalagem
Размеры упаковки
包装尺寸

Peso bruto
Peso bruto
Вес брутто
毛重





SOFTCOOKER S - SR

cottura a bassa temperatura
low temperature cooking

- Apparecchio per la cottura a bassa temperatura con riscaldamento statico dell'acqua.
- Struttura in acciaio inox, vasca di cottura gastronomico in acciaio inox.
- Pratiche maniglie per il trasporto della vasca.
- Potenti resistenze corazzate a contatto del fondo della vasca.
- Sistema elettronico di controllo della temperatura con visualizzazione della temperatura e del tempo di esercizio.
- Stesso sistema di controllo del Softcooker con ΔT di 0,2°C.
- 5 programmi memorizzabili.
- Temperatura selezionabile in °C e °F.
- Coperchio vasca fornito di serie.
- Versione R con rubinetto per lo scarico dell'acqua.

- *Low temperature cooking device with water static heating.*
- *Stainless steel structure and 1/1 GN made of stainless steel*
- *Practical handles to carry it easily*
- *Powerful shock-proof coated heating elements in contact with tank bottom*
- *Electronic control system of the temperature with working temperature display*
- *Same control system of Softcooker with ΔT of 0,2°C.*
- *5 storable programs*
- *Temperature setting in °C and °F.*
- *Equipped with lid*
- *R version with tap for discharging water.*



SOFTCOOKER S 1/1 GN
1.coperchio standard
standard lid



SOFTCOOKER S 2/3 GN
2.coperchio standard
standard lid



SOFTCOOKER S 2/3 GN



SOFTCOOKER S 1/1 GN



SOFTCOOKER SR 1/1 GN
4.coperchio standard
standard lid

SOFTCOOKER SR 2/3 GN
3.coperchio standard
standard lid

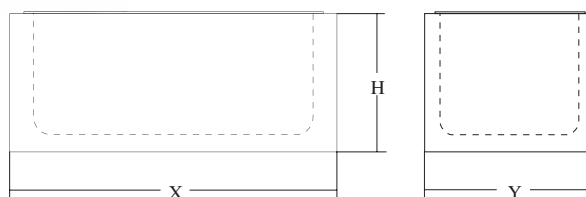

	Potenza Power Spannung Puissance	Alimentazione Power source Betriebsspannung Alimentation	Temperatura Temperature Temperatur	Capacità vasca Bowl capacity Becken Kapazität Capacité cuve	Capacità utile vasca Bowl filling level Becken Nutzliche Kapazität Capacité utile cuve	X	Y	H	Peso netto Net weight Nettogewicht Poids net	Dimensioni imballo Shipping Verpack abmessungen Dim. emballage	Peso lordo Gross weight Brutogewicht Poids brut
	watt		°C	lt	lt	mm	mm	mm	kg	mm	kg
Softcooker S - 2/3 GN	1150	230V/50Hz	24 ÷ 99	16,5	14	390	360	300	5	600x500x420	9
Softcooker SR - 2/3 GN	1150	230V/50Hz	24 ÷ 99	19	17	400	370	300	5,5	600x500x420	9
Softcooker S - 1/1 GN	1700	230V/50Hz	24 ÷ 99	26,5	22	565	360	300	16	600x500x420	20
Softcooker SR - 1/1 GN	1700	230V/50Hz	24 ÷ 99	29	25	575	370	300	16,5	600x500x420	20



SOFTCOOKER SR 2/3 GN

SOFTCOOKER SR 1/1 GN



SOFTCOOKER WI-FOOD

*cottura a bassa temperatura
low temperature cooking*

La rivoluzione nei sistemi di cottura a bassa temperatura è arrivata: il nuovo SOFTCOOKER Wi-Food di Sirman permette, tramite una APP gratuita, di accedere ad un mondo di ricette pronte, collaudate e di sicuro successo.

Si possono salvare e condividere ricette, si può pubblicizzare il proprio ristorante e attività, si possono salvare tutte le proprie esperienze e andarle a ritrovare con pochi click per ripeterle. Il tutto a bordo di una macchina potente, e flessibile, in grado di gestire fino a 80 Lt d'acqua, con un pratico ed immediato display touch dalla splendida visibilità.

Vincitore del premio SMART LABEL a Host 2015

- Struttura in alluminio anodizzato.
- Ampio display touch 5", IP 67.
- Pratica maniglia per il trasporto.
- APP gratuita scaricabile da www.softcooker.com
- L'APP permette di gestire più macchine in batteria.
- L'APP permette di gestire più livelli di cottura.

The revolution in low temperature cooking has arrived! Sirman's new Wi-Food SOFTCOOKER lets you access a vast number of tried and tested recipes via a free app. Recipes can be saved and shared, your restaurant or business can be advertised, and your comments recorded and recalled in just a few clicks. And all this comes from a powerful, flexible cooker capable of holding up to 80 litres of water, and with a practical, intuitive and high resolution touch-screen display. Winner of the SMART LABEL award at Host 2015.

- Anodized aluminium frame.
- Wide IP 67 touch display 5".
- Easy to handle holder.
- Free APP downloadable from www.softcooker.com
- More units can be managed from the APP.
- Multiple cooking stages can be managed by the APP.



SOFTCOOKER
Wi-food

1. Vasca inox con coperchio 1/1 GN opzionali
Optionals s/steel container with lid 1/1 GN





2. Morsetto per fissaggio pentola
Pot fixing clamp



3. Pratica maniglia per il trasporto.
Easy to handle holder

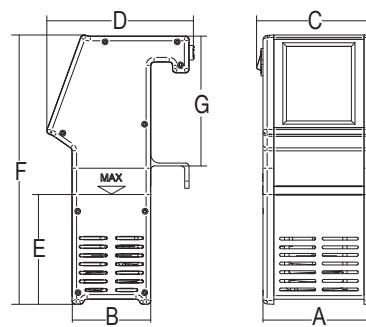

	Potenza Power Spannung Puissance	Alimentazione Power source Betriebsspannung Alimentation	Temperatura Temperature Temperatur	Capacità vasca Bowl capacity Becken Kapazität Capacité cuve	Capacità utile vasca Bowl filling level Becken Nützliche Kapazität Capacité utile cuve	A	B	C	D	E	F	G	Peso netto Net weight Nettogewicht Poids net	Dimensioni imballo Shipping Verpack, abmessungen Dim. emballage	Peso lordo Gross weight Bruttogewicht Poids brut
	watt	230V/50Hz	°C / °F	lt	lt	mm	mm	mm	mm	mm	mm	mm	kg	mm	kg
Softcooker Wi-Food	2000	230V/50Hz	40 ÷ 90 °C 104 ÷ 194 °F	-	-	155	109	164	203	152	377	180	4,5	330x455x240	5,5
Vasca / container 1/1 GN	-	-	-	27	22	-	-	-	-	-	-	-	7,7	720x500x350	11,5
Vasca / container 2/1 GN	-	-	-	57,5	43	-	-	-	-	-	-	-	13	750x650x400	16

Potencia
Potência
Мощность

Alimentación
Alimentação
Электропитание

Temperatura
Temperatura
Температура

Capacidad tina
Capacidade recipiente
Объем бункера

Capacidad útil tina
Capacidade útil recipiente
Полезный объем емкости

Peso neto
Peso líquido
Вес нетто

Dimensiones embalaje
Dimensões embalagem
Размеры упаковки

Peso bruto
Peso bruto
Вес брутто

4. Vasca inox con coperchio 2/1 GN opzionali
Optionals s/steel container with lid 2/1 GN





SOFTCOOKER Y09

*cottura a bassa temperatura
low temperature cooking*

- Riscaldatore termoregolato ad alta precisione.
- Visualizzatore di temperatura e tempo esercizio.
- 5 programmi memorizzabili
- Struttura in acciaio inox IP X3.
- Profondità di lavoro max 16,5 cm.
- Funzionamento ottimale fino a 80 lt.
- Dispositivo di protezione automatico in caso di utilizzo a secco.
- Ventola di circolazione per favorire una ottima miscelazione del prodotto.
- Dispositivo di blocco motore se rilevata sovratensione e sovratemperatura.

- High precision warmer with temperature control.
- Working temperature display.
- 5 storable programs.
- IP X3 protection rated stainless steel structure.
- Can be applied to the pot by means of a clamp. (max depth 16,5 cm)
- Best performances up to 80 lt.
- Protection device switches off the warmer in case of accidental use outside the liquid.
- Circulating pump to help the best product mixing.
- Temperature sensor to prevent overload and overheating.

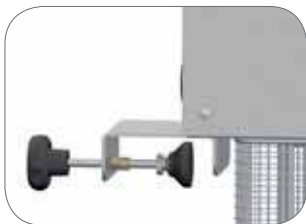

1. Morsetto per fissaggio pentola
Pot fixing clamp

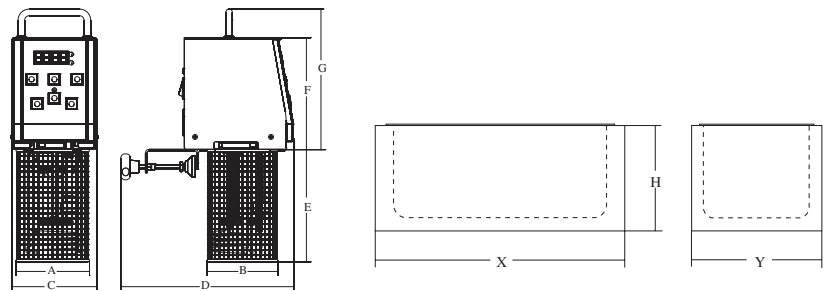

	Potenza Power Puissance	Alimentazione Power source Betriebsspannung Alimentation	Temperatura Temperature Temperatur	Capacità vasca Bowl capacity Becken Kapazität Capacité cuve	Capienza utile vasca Bowl filling level Becken Nutzfläche Capacité utile cuve	A	B	C	D	E	F	G	X	Y	H	Peso netto Net weight Nettogewicht Poids net	Dimensioni imballo Shipping Verpack abmessungen Dim. emballage	Peso lordo Gross weight Bruttogewicht Poids brut
	watt	230V/50Hz	°C	lt	lt	mm	mm	mm	mm	mm	mm	mm	mm	mm	mm	kg	mm	kg
Softcooker Y09	2000	230V/50Hz	24 ÷ 99	-	-	110	105	130	260	170	170	210	-	-	-	4,5	330x455x240	5,5
Vasca / container 1/1 GN	-	-	-	27	22	-	-	-	-	-	-	-	565	360	230	7,7	720x500x350	11,5
Vasca / container 2/1 GN	-	-	-	57,5	43	-	-	-	-	-	-	-	650	530	230	13	750x650x400	16

2. Supporto vasche fino a 80 lt opzionale
Optional containers support until 80 lt

3. Vasche inox con coperchio opzionali
Optional s/steel containers with lid

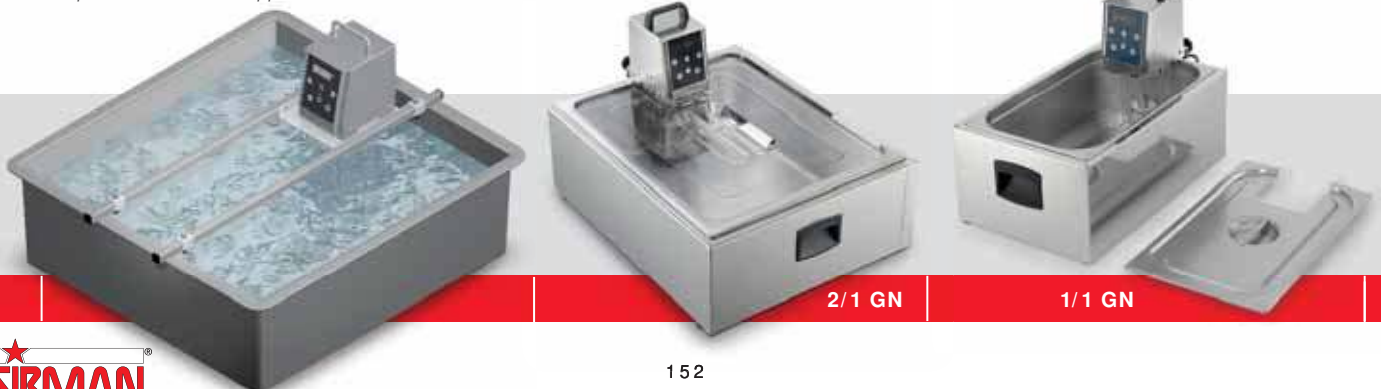

Potencia Potência Мощность 功率	Alimentación Alimentação Электронпитание 電源	Temperatura Temperatura Температура 温度	Capacidad tina Capacidade recipiente Объем бункера 容器容積	Capacidad útil tina Capacidade útil recipiente Пользательный объем емкости 容器可加入量	A	B	C	D	E	F	G	X	Y	H	Peso neto Peso líquido Bec netto 淨重	Dimensiones embalaje Dimensões embalagem Пакебычвары 包裝尺寸	Peso bruto Peso bruto Bec 6pyтто 毛重
--	--	---	--	--	---	---	---	---	---	---	---	---	---	---	--	--	--



ALISEO

forni a convezione convection ovens

- Struttura in acciaio inox interno ed esterno.
- Distanza tra ripiani cm 8
- Camera interna con angoli raggiati per una pulizia facile e veloce.
- Porta in acciaio inox, con doppio vetro.
- Illuminazione interna con due lampade.
- Regolazione termostatica della temperatura.
- Timer di controllo cottura da 0' a 120' o continuo.

ALISEO PLUS:

- Umidificatore di serie.
- Sistema ventola potenziata per una migliore distribuzione della temperatura.

ALISEO 2/3 PLUS B:

- Ventola con inverter per una migliore distribuzione della temperatura.

- *Stainless steel construction including chamber.*
- *Distance between shelves cm 8.*
- *Seamless, round-cornered and easy to clean chamber to prevent contamination.*
- *Double glass stainless steel door.*
- *Effective 2 lamp chamber lighting.*
- *Thermostatically controlled temperature from 25°C to 300°C (77°F to 572°F).*
- *Choice of 0' to 120' programmable timer or continuous operation.*

ALISEO PLUS:

- *Humidifier.*
- *Inverter system allows for an even and effective heat distribution.*

ALISEO 2/3 PLUS B:

- *Inverter system allows for an even and effective heat distribution.*



ALISEO 4



1. n.4 griglie di serie facilmente rimovibili e doppia ventilazione
n.4 removable racks standard and double ventilation

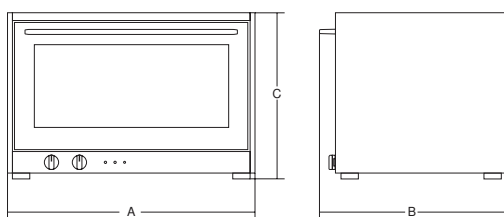

	Potenza Power Spannung Puissance	Alimentazione Power source Betriebsspannung Alimentation	Temperatura Temperature Temperatur Température	Numero ripiani Number of shelves Anzahl Etagen Nombre de étagère	Dimensioni teglie Trays dimensions Bleche abmessungen Dimensions bacs	Dimensioni interne Inner dimensions Garraumabmessungen Dimensions intérieures	A	B	C	Peso netto Net weight Nettogewicht Poids net	Dimensioni imballo Shipping Verpack. abmessungen Dim. emballage	Peso lordo Gross weight Bruttogewicht Poids brut
	watt	230V/50Hz	°C	n.	mm	mm	mm	mm	mm	kg	mm	kg

Aliseo 2/3	2600	230V/50Hz	25 ÷ 300	4	440x330	480x360 h.300	600	625	515	35	750x1000x850	43
Aliseo 2/3 Plus	3200	230V/50Hz	25 ÷ 300	4	440x330	480x360 h.300	600	625	515	35	750x1000x850	43
Aliseo 2/3 Plus B	3200	230V/50Hz	25 ÷ 300	4	2/3 gastro	480x420 h.340	620	650	585	37	750x1000x850	45
Aliseo 2/3 Grill	2600 grill 2800 conv.	230V/50Hz	25 ÷ 300	4	2/3 gastro	480x420 h.340	620	650	585	37	750x1000x850	45
Aliseo 4	1ph 3400 3ph 5200	230V/50Hz 380V/50Hz	25 ÷ 300	4	600x400 1/1 gastro	650x460 h.360	820	760	610	54	750x1000x850	66
Aliseo 4 Plus	6400	380V/50Hz	25 ÷ 300	4	600x400 1/1 gastro	650x460 h.360	820	760	610	54	750x1000x850	66

2. n.4 griglie di serie facilmente rimovibili e ventilazione singola
n.4 removable racks standard and single ventilation

	Potencia Potência Мощность	Alimentación Alimentação Электропитание	Temperatura Temperatura Температура	Número planos Número planos Колличество полок	Dimensiones bandejas Dimensões bandejas Размеры gastronormальных	Dimensiones internas Dimensões internas Внутренние размеры	A	B	C	Peso neto Peso líquido Вес нетто	Dimensiones embalaje Dimensões embalagem Размеры упаковки	Peso bruto Peso bruto Вес брутто
	Watt	230V/50Hz	°C	n.	mm	mm	mm	mm	mm	kg	mm	kg



ALISEO 2/3



BASIC - FISSA - PRO

salamandre / finishing ovens

FISSA E BASIC

- Realizzate in acciaio inox.
- Simostato per la regolazione dell'intensità del calore.
- Griglia di cottura e griglia di protezione resistenze, in acciaio cromato.
- Cassetto raccogli briciole facilmente estraibile.
- Griglia di cottura posizionabile su quattro livelli in base alle esigenze di cottura del prodotto.

PRO

- Carcassa in acciaio inox.
- Corpo riscaldante regolabile in altezza.
- Cassetto raccogli briciole facilmente estraibile.
- Griglia di cottura in acciaio cromato.
- Resistenze corazzate.
- Camini di sfogo. Simostati elettronici.

FISSA AND BASIC

- Made from stainless steel.
- Heating up controlled by a symostat.
- Galvanized steel gridiron and heating elements protection grill.
- Easy to remove crumb pan.
- Gridiron can be placed on 4 levels according to the cooking requirements.

PRO

- Stainless steel body.
- Height on the heating structure can be adjusted.
- Easy to remove crumb pan.
- Galvanized steel gridiron.
- Shock proof heating elements.
- Vent outlets. Electronic symosthats.



SALAMANDRA PRO 1/1 G



1. Particolare supporto a muro
Wall mounted support

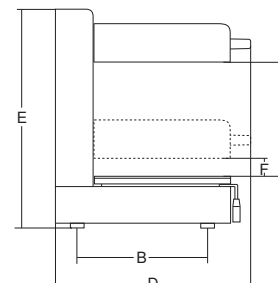
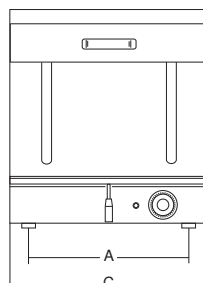
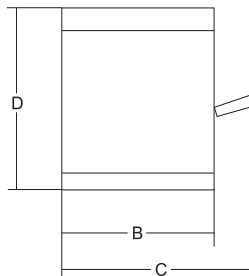
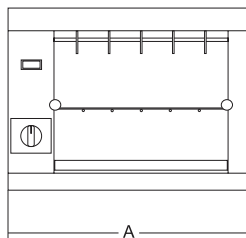

Potenza
Power
Spannung
Puissance

Alimentazione
Power source
Betriebsspannung
Alimentation

Zone riscaldanti
Heating areas
Heizzone
Zones chauffant

Dimensioni interne
Internal dimensions
Innenmaße
Dimensions intérieures

Dimensioni vano cottura
Cooking compartment dim.
Oberfläche
Dimensions module de cuisson

Peso netto
Net weight
Nettogewicht
Poids net

Dimensioni imballo
Shipping
Verpack. abmessungen
Dim. emballage

Peso lordo
Gross weight
Bruttogewicht
Poids brut

	Watt	n.	mm	mm	mm	mm	mm	mm	mm	mm	mm	Kg	mm	kg
Salamandra BASIC	2800	230V 50/60 Hz F+N	1	480x330 h.320	-	620	350	445	430	-	-	16	670x450x480	18
Salamandra FISSA	2800	230V 50/60 Hz F+N	1	480x330 h.320	-	620	350	445	430	-	-	18,5	670x450x480	20,5
Salamandra PRO 1/2 G	1700	230V 50/60 Hz F+N	1	-	385x350	330	400	400	545	510	30	45	500x630x650	50
Salamandra PRO 1/1 G	3400	230V 50/60 Hz F+N	2	-	585x350	510	400	600	545	510	30	56	750x630x630	66

Potencia
Potência
Мощность
功率

Alimentación
Alimentação
Электропитание
電源

Zonas calentadoras
Zonas de aquecimento
Зоны нагрева
加熱區

Dimensiones internas
Dimensões internas
Внутренние размеры
內部尺寸

Dimensiones del espacio de cocción
Dimensões espaço de cozimento
Размеры зоны выпекания
蒸腔間尺寸

Peso líquido
Peso líquido
Вес нетто
淨重

Dimensiones embalaje
Dimensões embalagem
Размеры упаковки
包裝尺寸

Peso bruto
Peso bruto
Вес брутто
毛重



SALAMANDRA PRO 1/2 G



SALAMANDRA FISSA - BASIC



P.I. 2,5 - 3,5 piastre induzione induction hobs



P.I 3,5 KW

- Facilmente installabili in qualsiasi piano liscio presente in cucina, nei ristoranti e nelle sale da pranzo come dimostrazione, o la preparazione di piatti particolari di fronte ai clienti, grazie all'assenza di fumi e odori.
- Dotate di pulsantiera digitale graduata.
- Estremamente facili da utilizzare e da pulire.
- Superficie di cottura liscia, pratica da pulire.
- Massima sicurezza grazie alla superficie di cottura che non si riscalda.
- Risparmio energetico grazie alla velocità di riscaldamento e all'elevata resa.
- Non sono previsti tempi di pre-riscaldamento ed il consumo di energia si blocca non appena la pentola viene rimossa dal piano.

- *The induction hobs are easy to install on every working surface in kitchens, restaurants or dining rooms; thanks to the absence of fumes they are perfect for public cooking performances or when the preparation is made in view of customers.*
- *Graduated digital controls.*
- *Extremely easy to use and to clean.*
- *Smooth cooking surface makes cleaning easy.*
- *Safe operations are ensured by the cooking surface which is never heating up.*
- *Induction hobs are energy saving thanks to heating efficiency and no need to heat up.*
- *Electric absorption is stopped when the pan is removed from the hob surface.*



1. Piastre modulari
Modular grills

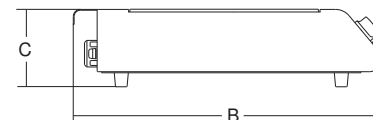
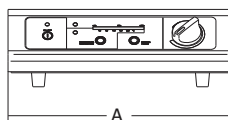

Dimensioni foro per incasso
Cavity dimensions for built-in models
Lochabmessungen für Einbau
Dimensions trou

Peso netto
Net weight
Poids net

Dimensioni imballo
Shipping
Dim. emballage

Peso lordo
Gross weight
Bruttogewicht
Poids brut

Potenza
Power
Spannung
Puissance

Alimentazione
Power source
Betriebsspannung
Alimentation

Sup. utile
Useful surface
Nutzfläche
Surface utile

A B C

Peso netto
Net weight
Poids net

Dimensioni imballo
Shipping
Dim. emballage

Peso lordo
Gross weight
Bruttogewicht
Poids brut

	Watt		mm	mm	mm	mm	mm	Kg	mm	kg
P.I. 2,5 Kw	2500	230V/50Hz	322x270	-	320	440	115	7,5	500x370x180	9
P.I. 2,5 Kw da incasso	2500	230V/50Hz	322x270	307x470	320	500	115	9	500x370x180	10,5
P. I. 3,5 Kw	3500	230V/50Hz	330x275	-	340	460	135	11	510x380x200	12,5

Potencia
Potencia
Mощность
功率

Alimentación
Alimentação
電源
Электроснабжение

Superficie utili
Superficie utili
有用表面
Полезная площадь

A B C

Peso líquido
Peso líquido
Вес нетто
淨重

Dimensiones embalaje
Dimensiones embalagem
Paquete embalagem
包裝尺寸

Peso bruto
Peso bruto
Вес брутто
毛重

Dimensiones orificio para encaje
Dimensões do furo de embutida
Paquete embalagem
嵌型內腔尺寸



P.I. 2,5 KW AD INCASSO



P.I. 2,5 KW



SNACK E PIZZA | SNACK AND PIZZA

Studiata appositamente per soddisfare le esigenze dei professionisti della piccola ristorazione – pub, bar, piccoli ristoranti, ecc... - la 'linea snack' firmata Sirman propone tostiere, piastre, girawurstel, mixer e molti altri strumenti che si impongono nel mercato per l'estrema praticità d'uso, l'assoluta attenzione riservata ai criteri igienici e la facilità di pulizia. A tali grandi vantaggi, si deve aggiungere il raffinato design che contraddistingue tutti i prodotti della linea snack e, soprattutto, la particolare attenzione rivolta alla riduzione del consumo energetico.

Studied specifically to meet the professional's needs in small restaurants, pubs, bars, etc., Sirman's "Snack range" includes toasters, hot plates, frankfurter spits, mixers and many other kitchen tools that have become popular on the market because they are so practical to use, designed with a great attention to hygienic aspects and easy to clean. These great advantages go hand in hand not to only with an elegant design that distinguishes all the products in the Snack range but also, and equally important, with a particular attention to reducing energy consumption.





ELIO

piastre sandwich grills

- Facile da maneggiare e da posizionare, grazie alle sue piccole dimensioni, offre in poco spazio una ottimale superficie di lavoro.
- Disponibile con piastre sia lisce che rigate
- Struttura in acciaio inox.
- Piastre in ghisa con trattamento di vetroceramicatura: massima robustezza e durata ottima conducibilità termica estrema facilità di pulizia
- Piastre superiori con durezza regolabile ad esigenza dell'operatore.
- Piastra superiore autobilanciata.
- Resistenze corazzate aderenti alle piastre per una ottimale conducibilità termica.
- Termostato regolabile fino a 300 °C.
- Timer meccanico opzionale.

- *Thanks to its small size, it is easy to handle and to position, offering as well a large cooking surface.*
- *Ribbed and smooth surfaces available.*
- *Stainless steel construction.*
- *Cast iron plates with ceramic coating treatment: highest sturdiness and life time; perfect thermal conductivity; very easy to clean.*
- *Adjustable upper plates.*
- *Self balancing upper plate.*
- *Shock-proof coated heating elements, adherent to the plates for a perfect thermal conductivity.*
- *Adjustable thermostat up to 300° C.*
- *Mechanical timer available.*



ELIO RR

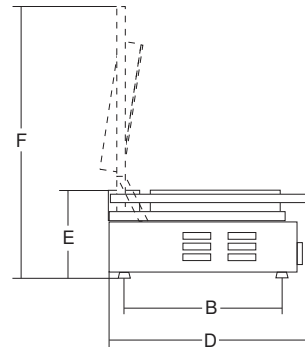
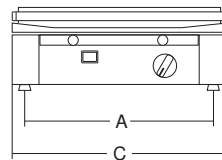

	Potenza Power Spaamung Puissance	Alimentazione Power source Betriebsspannung Alimentation	Sup. utile Useful surface Nutzfläche Surface utile	A	B	C	D	E	F	Peso netto Net weight Nettogewicht Poids net	Dimensioni imballo Shipping Verpack. abmessungen Dim. emballage	Peso lordo Gross weight Bruttogewicht Poids brut
	Watt		mm	mm	mm	mm	mm	mm	mm	kg	mm	kg
Elio	1550	230V 50/60 Hz F+N	250x255	215	275	260	435	235	500	16	490x320x330	17
	Potencia Potência Мощность 功率	Alimentación Alimentação Электронпряжение 电压	Superficie útil Superficie utili Пользная площадь 有用表面	A	B	C	D	E	F	Peso netto Peso líquido Бес нетто 净重	Dimensiones embalaje Dimensões embalagem Размеры упаковки 包装尺寸	Peso bruto Peso bruto Бес брутто 毛重



ELIO LR TIMER

PaniNonstick®



CORT LR CON TIMER



CORT RR PS CON TIMER



CORT

piastre sandwich grills

- Facile da maneggiare e da posizionare, grazie alle sue piccole dimensioni, offre in poco spazio una ottimale superficie di lavoro.
- Disponibile con piastre sia lisce che rigate
- Struttura in acciaio inox.
- Piastre in ghisa con trattamento di vetroceramicatura: massima robustezza e durata ottima conducibilità termica estrema facilità di pulizia
- Piastre superiori con durezza regolabile ad esigenza dell'operatore.
- Piastra superiore autobilanciata.
- Resistenze corazzate aderenti alle piastre per una ottimale conducibilità termica.
- Termostato regolabile fino a 300 °C.
- Timer meccanico opzionale.
- Solo modelli PS con piastre in ghisa smontabili per la pulizia.

- *Thanks to its small size, it is easy to handle and to position, offering as well a large cooking surface.*
- *Ribbed and smooth surfaces available.*
- *Stainless steel construction.*
- *Cast iron plates with ceramic coating treatment: highest sturdiness and life time; perfect thermal conductivity; very easy to clean.*
- *Adjustable upper plates;*
- *Self balancing upper plate;*
- *Shock-proof coated heating elements, adherent to the plates for a perfect thermal conductivity.*
- *Adjustable thermostat up to 300° C.*
- *Mechanical timer available.*
- *Only PS models: cast iron plates removable for cleaning.*

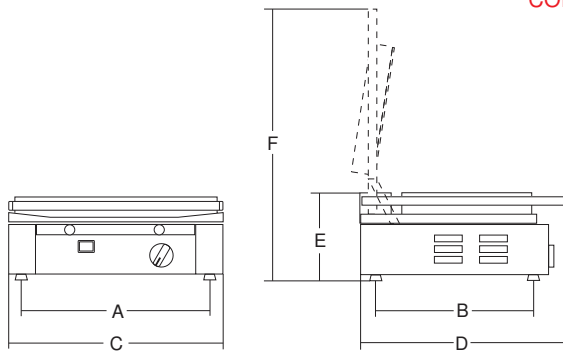

	Potenza Power Spannung Puissance	Alimentazione Power source Betriebsspannung Alimentation	Sup. utile Useful surface Nutzfläche Surface utile	A	B	C	D	E	F	Peso netto Net weight Nettogewicht Poids net	Dimensioni imballo Shipping Verpack abmessungen Dim. emballage	Peso lordo Gross weight Brutogewicht Poids brut
	Watt		mm	mm	mm	mm	mm	mm	mm	kg	mm	kg
Cort	2100	230V 50/60 Hz F+N	355x255	340	275	380	435	235	500	22	430x420x270	23
Cort PS	2100	230V 50/60 Hz F+N	355x255	340	275	380	420	155	540	22	430x420x270	23

	Potencia Potência Мощность 功率	Alimentación Alimentação Электропитание 電源	Superficie útil Superficie utili Полезная площадь 有用表面	A	B	C	D	E	F	Peso netto Peso líquido Вес нетто 淨重	Dimensiones embalaje Dimensões embalagem Размеры упаковки 包裝尺寸	Peso bruto Peso bruto Вес брутто 毛重
--	--	---	---	---	---	---	---	---	---	---	---	--

1. Piastre in ghisa smontabili
Cast iron plates removable



CORT RR PS TIMER



CORT RR



CORT XX TIMER



PD

piastre sandwich grills

www.paninigrill.com

- Piastre resistenti nel tempo create in ghisa trattata con smalto alimentare vetrificato, per garantire igienicità e inattaccabilità da acidi e sali oltre ad una assoluta resistenza all'ossidazione.
- Disponibile con piastre in ghisa lisce, rigate o miste o con piastre inox lisce.
- Struttura in acciaio inox.
- Piastre in ghisa con trattamento di vetroceramicatura:
- Massima robustezza e durata. Ottima conducibilità termica. Estrema facilità di pulizia.
- Piastre superiori autobilanciate con durezza regolabile ad esigenza dell'operatore
- Resistenze corazzate aderenti alle piastre per una ottimale conducibilità termica.
- Due termostati regolabili fino a 300 °C permettono di gestire separatamente le due metà della piastra.
- Ideali per grossi carichi di lavoro e uso continuo.
- Timer meccanico opzionale.
- Solo modelli PS con piastre in ghisa smontabili per la pulizia.



PD LR TIMER

PD PS RR
1. Piastre in ghisa smontabili
Cast iron plates removable

- Long life cast iron plates, which ensure hygiene, acid and salt proofness and resistance to oxidation.
- Ribbed, smooth or mixed ribbed/smooth cast iron or smooth stainless steel surfaces available.
- Stainless steel construction.
- Cast iron plates with ceramic coating treatment.
- Highest sturdiness and life time. Perfect thermal conductivity. Very easy to clean.
- Self balancing adjustable upper plates;
- Shock-proof coated heating elements, adherent to the plates for a perfect thermal conductivity.
- Two adjustable thermostats up to 300° C, which enable to use the plates sepa-rately.
- Heavy-duty machine.
- Mechanical timer available.
- Only PS models: cast iron plates removable for cleaning.



	Potenza Power Spannung Puissance	Alimentazione Power source Betriebsspannung Alimentation	Sup. utile Useful surface Nutzfläche Surface utile	A	B	C	D	E	F	Peso netto Net weight Nettogewicht Poids net	Dimensioni imballo Shipping Verpack abmessungen Dim: emballage	Peso lordo Gross weight Bruttogewicht Poids brut
	Watt		mm	mm	mm	mm	mm	mm	mm	kg	mm	kg
PD	3000	230V 50/60 Hz F+N	500x255	475	275	515	435	235	500	28	560x430x270	30
PDR PS	3000	230V 50/60 Hz F+N	500x255	475	275	526	435	235	540	28	560x430x270	30
PDC	3000	230V 50/60 Hz F+N	500x255	475	275	515	435	235	500	26	560x430x270	27
PD Wafer	3000	230V 50/60 Hz F+N	ø 170	475	275	515	435	235	500	34	560x430x270	36



PD MR

PDC RR

PD RR TIMER

PD XX TIMER

PD WAFER



PD POWER

piastre sandwich grills



- Piastra superiore autobilanciata.
 - Resistenze corazzate aderenti alle piastre per una ottimale conducibilità termica.
 - Termostato regolabile fino a 300 °C.
 - Ideali per grossi carichi di lavoro e uso continuo.
 - Protezione termica sulle 4 resistenze.
 - 2 timer di serie.
 - Piedini rialzati per facilitare la pulizia anche sotto la piastra.
 - Vaschetta capiente raccogli briciole.
 - Coperchio molle con maniglia facilmente estraibile.
 - Distanziali laterali di serie.
- *Self balancing upper plate.*
 - *Shock-proof coated heating elements, adherent to the plates for a perfect thermal conductivity.*
 - *Adjustable thermostat up to 300° C.*
 - *Heavy-duty machine.*
 - *Thermally protected heating elements.*
 - *Comes with 2 timers.*
 - *Higher legs to keep your counter under the unit clean.*
 - *Detachable front drip tray.*
 - *Removable hinges cover.*
 - *Comes with side spacers.*

PD RR POWER TIMER

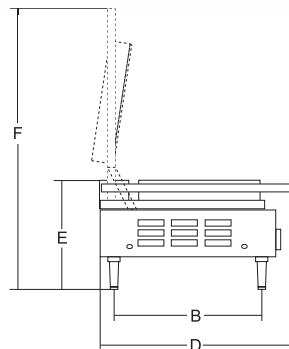
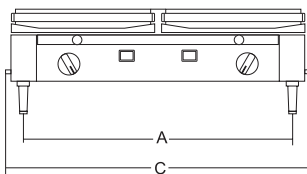

	Potenza Power Spannung Flussance	Alimentazione Power source Betriebspannung Alimentation	Sup. utile Useful surface Nutzfläche Surface utile	A	B	C	D	E	F	Peso netto Net weight Nettogewicht Poids net	Dimensioni imballo Shipping Verpack. abmessungen Dim. emballage	Peso lordo Gross weight Bruttogewicht Poids brut
	Watt		mm	mm	mm	mm	mm	mm	mm	kg	mm	kg
PD Power	4500	400V 50/60 Hz F+N	500x255	475	275	545	435	300	660	33	560x540x300	35

Potencia
Potencia
Mощность
功率

Alimentación
Alimentação
Электропитание
電源

Superficie útil
Superficie útil
Пользательная площадь
有用表面

A B C D E F

Peso netto
Peso líquido
Вес нетто
淨重

Dimensiones embalaje
Dimensões embalagem
Размеры упаковки
包裝尺寸

Peso bruto
Peso bruto
Вес брутто
毛重



PD MR POWER TIMER



PD LR POWER TIMER



TOP

piastre sandwich grills

- Piastre resistenti nel tempo create in ghisa trattata con smalto alimentare vetrificato, per garantire igienicità e inattaccabilità da acidi e sali oltre ad una assoluta resistenza all'ossidazione.
- Disponibile con piastre in ghisa lisce, rigate o miste o con piastre inox lisce
- Struttura in acciaio inox.
- Piastre in ghisa con trattamento di vetroceramicatura:
Massima robustezza e durata
Ottima conducibilità termica
Estrema facilità di pulizia
- Resistenze corazzate aderenti alle piastre per una ottimale conducibilità termica e rapido riscaldamento.
- Due termostati regolabili fino a 300 °C permettono di gestire separatamente le due metà della piastra.
- Ideali per grossi carichi di lavoro e uso continuo.
- Timer meccanico opzionale.



TOP R TIMER

- Long life cast iron plates, which ensure hygiene, acid and salt proofness and resistance to oxidation.
- Ribbed, smooth or mixed ribbed/smooth cast iron or smooth stainless steel surfaces available.
- Stainless steel construction.
- Cast iron plates with ceramic coating treatment:
Highest sturdiness and life time;
Perfect thermal conductivity;
Very easy to clean.
- Self balancing adjustable upper plates.
- Shock-proof coated heating elements, adherent to the plates for a perfect thermal conductivity.
- Two adjustable thermostats up to 300° C, which enable to use the plates separately.
- Heavy-duty machine.
- Mechanical timer available.

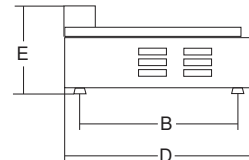
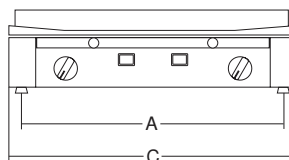

	Potenza Power Spannung Puissance	Alimentazione Power source Betriebsspannung Alimentation	Sup. utile Useful surface Nutzfläche Surface utile	A	B	C	D	E	Peso netto Net weight Nettogewicht Poids net	Dimensioni imballo Shipping Verpack. abmessungen Dim. emballage	Peso lordo Gross weight Bruttogewicht Poids brut
	Watt		mm	mm	mm	mm	mm	mm	kg	mm	kg
TOP	1800	230V 50/60 Hz F+N	500x255	475	275	515	435	170	18	560x430x270	20
	Potencia Potência Мощность 功率	Alimentación Alimentação Электроснабжение 电源	Superficie útil Superficie útil Полезная площадь 有用表面	A	B	C	D	E	Peso neto Peso líquido Bec netto 净重	Dimensiones embalaje Dimensões embalagem Размер упаковки 包装尺寸	Peso bruto Peso bruto Вес брутто 毛重



TOP L TIMER



TOP X TIMER



CREPIERE

crepiera tonda crepe makers



- Struttura in acciaio inox.
- Forma semplice e compatta.
- Nessun ingombro oltre alla superficie di lavoro.
- Piano di cottura in ghisa cromata per una distribuzione termica ottimale.
- Controllo a mezzo simostato.
- Resistenze corazzate.
- Piedini regolabili in altezza per una sicura e stabile collocazione.
- Disponibile sia con piano liscio che con bordo rialzato.

- *Stainless steel construction.*
- *Simple and compact shape.*
- *Chromium-coated cast iron cooking surface for a perfect thermal distribution.*
- *Symosthat control.*
- *Shock-proof coated heating elements.*
- *Adjustable feet for a safe and steady placing.*
- *With smooth surface or with mould available.*

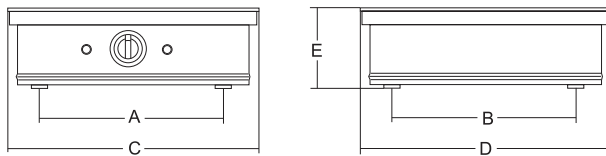

	Potenza Power Spannung Puissance	Alimentazione Power source Betriebspannung Alimentation	Sup. utile Useful surface Nutzfläche Surface utile	A	B	C	D	E	Peso netto Net weight Nettogewicht Poids net	Dimensioni i imballo Shipping Verpack. abmessungen Dim. emballage	Peso lordo Gross weight Bruttogewicht Poids brut
	Watt		mm	mm	mm	mm	mm	mm	kg	mm	kg
Creperia Tonda	2000	230V 50/60 Hz F+N	∅ 350	200	200	350	350	135	9,5	410x430x220	10,5
	Potencia Potência Мощность 功率	Alimentación Alimentação Электропитание 電源	Superficie útil Superfície útil Полезная площадь 有用表面	A	B	C	D	E	Peso neto Peso líquido Bec netto 淨重	Dimensiones embalaje Dimensões embalagem Размеры упаковки 包裝尺寸	Peso bruto Peso bruto Bec bruto 毛重



CREPIERA TONDA CON INCAVO



CORT V. - PD V. - TOP V.

piastre vetroceramica ceramic glass sandwich grills

- Struttura in acciaio inox.
- Piani di cottura in vetroceramica Ceran®.
- Controllo a mezzo termostato.
- Piano di cottura raccordato al corpo macchina facile da pulire.
- Pratico cassetto raccogli liquidi e residui di cottura.
- Piastre superiori autobilancianti e regolabili a piacere dell'operatore.
- Piedini regolabili in altezza per un maggior adeguamento piano di lavoro.
- Ideali quando la messa in temperatura da freddo diventa prioritaria.

- *Stainless steel construction.*
- *Ceran® ceramic-glass cooking surfaces.*
- *Thermostat control.*
- *Useful drip tray for liquids and other cooking leavings.*
- *Easy to clean.*
- *Self balancing adjustable upper plates.*
- *Adjustable feet for a safe and steady placing.*
- *Ideal for a fast achievement of working temperature.*



PD V LL

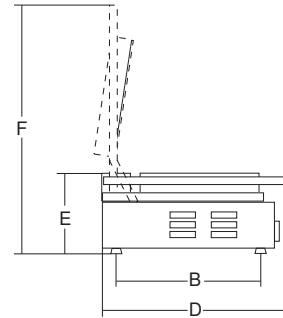
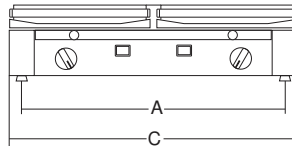

	Potenza Power Spannung Puissance	Alimentazione Power source Betriebsspannung Alimentation	Sup. utile Useful surface Nutzfläche Surface utile	A	B	C	D	E	F	Peso netto Net weight Nettogewicht Poids net	Dimensioni imballo Shipping Verpack-abmessungen Dim. emballage	Peso lordo Gross weight Bruttogewicht Poids brut
	Watt		mm	mm	mm	mm	mm	mm	mm	kg	mm	kg
Cort V.	3000	230V 50/60 Hz F+N	340x290	375	340	435	490	170	550	14	430x560x270	16
Cort Top V.	1500	230V 50/60 Hz F+N	340x290	375	340	435	455	170	-	6,5	430x560x270	8,5
PD V.	3000	230V 50/60 Hz F+N	(260x290) x2	645	365	700	490	170	550	22	760x560x280	24,5
PD Top V.	1500	230V 50/60 Hz F+N	(260x290) x2	645	365	700	490	170	-	9	760x560x280	11

Potencia
Potência
Мощность
功率

Alimentación
Alimentação
Электроснабжение
电源

Superficie útil
Superficie útil
Пользная площадь
有用表面

A B C D E F

Peso netto
Peso líquido
Bec netto
淨重

Dimensiones embalaje
Dimensões embalagem
Упаковки
包装尺寸

Peso bruto
Peso bruto
Bec брутто
毛重



CORT TOP V. L

CORT V. LL

CORT V. LR

CORT V. RR

PD TOP V. L



Energy Saving!



PD VC RR

PD VC

piastre vetroceramica ceramic glass sandwich grills

- Struttura in acciaio inox.
- Piani di cottura in vetroceramica Ceran®.
- Controllo a mezzo termostato.
- Piano di cottura raccordato al corpo macchina facile da pulire.
- Pratico cassetto raccogli liquidi e residui di cottura.
- Piastre superiori autobilancianti e regolabili a piacere dell'operatore.
- Piedini regolabili in altezza per un maggior adeguamento piano di lavoro.
- Ideali quando la messa in temperatura da freddo diventa prioritaria.

- *Stainless steel construction.*
- *Ceran® ceramic-glass cooking surfaces.*
- *Thermostat control.*
- *Useful drip tray for liquids and other cooking leavings.*
- *Easy to clean.*
- *Self balancing adjustable upper plates.*
- *Adjustable feet for a safe and steady placing.*
- *Ideal for a fast achievement of working temperature.*

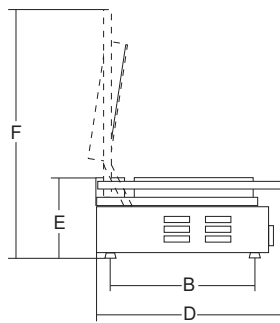
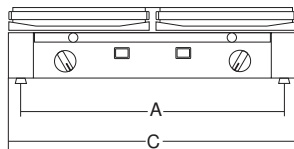

1. Cassetto raccolta liquidi e residui di cottura
Useful drip tray for liquids and other cooking leavings

	Potenza Power Spannung Puissance	Alimentazione Power source Betriebsspannung Alimentation	Sup. utile Useful surface Nutzfläche Surface utile	A	B	C	D	E	F	Peso netto Net weight Nettogewicht Poids net	Dimensioni imballo Shipping Verpack abmessungen Dim. emballage	Peso lordo Gross weight Bruttogewicht Poids brut
	Watt	230V 50/60 Hz F+N	mm	mm	mm	mm	mm	mm	mm	kg	mm	kg
PD VC	3200	230V 50/60 Hz F+N	530x255	542	330	592	441	166	565	30	760x560x280	33
	Potencia Potencia Мощность 功率	Alimentación Alimentação Электропитание 电源	Superficie útil Superficie útil Поплезная площадь 有用表面	A	B	C	D	E	F	Peso neto Peso líquido Bec netto 净重	Dimensiones embalaje Dimensões embalagem Размеры упаковки 包装尺寸	Peso bruto Peso bruto Bec bruto 毛重



PD VC LR



4Q - 6Q - 12Q

tostiere sandwich toasters

- Ideali per riscaldare pizze, panini e cibi precotti; cucinare hamburger, würstel, toast farciti e piadine.
- Costruite interamente in acciaio inox.
- Griglie facilmente smontabili per la pulizia.
- Cassetto raccoglibriciole asportabile.
- Pinze in acciaio cromato in dotazione.
- Disponibili sia con resistenze e tubi al quarzo che con resistenze corazzate.
- Timer da 1 a 15 minuti.

Opzionale:

- deviatore per esclusione resistenza inferiore
- 2. Pinza lunga / 3. griglia intera / 4. griglia doppia

- *Ideal for heating up pizzas, sandwiches and ready-cooked foods, for cooking hamburgers, wüstels and rolls.*
- *Stainless steel construction.*
- *Easy to clean grills.*
- *Removable drip tray.*
- *Chromium-plated steel pincers.*
- *Elements with quartz tubes or shock-proof coated heating elements available.*
- *15 minutes timer.*

Optionals:

- *selector to switch off the lower heating elements*
- *2. Extra long sandwich tongs / 3. Full-size grate / 4. Double grate*



4Q

1. Pinze di serie
Standard tongs

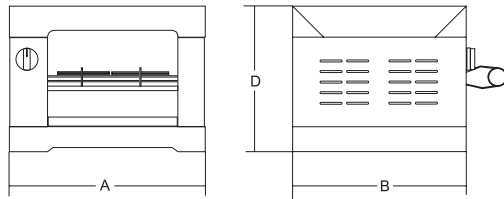

Potenza
Power
Spannung
Puissance

Alimentazione
Power source
Betriebsspannung
Alimentation

Capacità toast
Toast capacity
Toast Kapazität
Toast capacite

Resistenze al quarzo
Quartz heating elements
Quartz widerstände
Resistências a quartz

Resistenze corazzate
Shock-proof coated heating elements
Geplatzerte Widerstände
Resistências reforçadas

Dimensioni interne
Internal dimensions
Innenmaße
Dimensions intérieures

A B C D

Peso netto
Net weight
Nettogewicht
Poids net

Dimensioni imballo
Shipping
Verpack-abmessungen
Dim. emballage

Peso lordo
Gross weight
Bruttogewicht
Poids brut

	Watt	n.			mm	mm	mm	mm	mm	Kg	mm	kg	
4Q/D	1600	230V/50 Hz	4	si	no	235x240	360	265	410	240	6	550x320x300	7
6Q/D	2400	230V/50 Hz	6	si	no	355x240	475	265	410	240	7,5	550x320x300	8,5
6Q/D	2800	230V/50 Hz	6	si	no	355x240	475	265	410	240	7,5	550x320x300	8,5
6C/D	2900	230V/50 Hz	6	no	si	355x240	475	265	410	240	7,5	550x320x300	8,5
12Q	3000	230V/50 Hz	12	si	no	355x240	475	265	410	365	9	570x320x420	11
12Q	3600	230V/50 Hz	12	si	no	355x240	475	265	410	365	9	570x320x420	11
12C	4350	230V/50 Hz	12	no	si	355x240	475	265	410	365	9	570x320x420	11

Potencia
Potência
Мощность
功率

Alimentación
Alimentação
Электроснабжение
电源

Capacidad emparedados
Capacidade tostadeira
Коп-во тостов
吐司容量

Resistencias de cuarzo
Resistência ao quartz
Кварцевые нагревательные элементы
石英加热元件

Resistências acorazadas
Resistência revestida
Армированные нагревательные элементы
防震涂层加热元件

Dimensiones internas
Dimensões internas
Внутренние размеры
内部尺寸

A B C D

Peso neto
Peso líquido
Вес нетто
淨重

Dimensiones embalaje
Dimensões embalagem
Размеры упаковки
包裝尺寸

Peso bruto
Peso bruto
Вес брутто
毛重



12Q



6Q



5. Resistenze corazzate / Shock-proof resistences



TO STONE

tostiera sandwich toaster



- Costruito interamente in acciaio inox.
- Griglie facilmente smontabili per la pulizia.
- Cassetto raccoglibriciole asportabile.
- In dotazione 2 griglie in acciaio cromato.
- Tubi al quarzo efficienti e veloci
- Ideale per riscaldare pizze, panini e cibi precotti; cuocere bruschette, hamburger, wurstel, toast farciti e piadine, come pure gamberoni, sardine, verdure e qualsiasi prodotto che necessiti di una veloce e marcata grigliatura.

- Entirely built out of stainless steel.
- Grills that are easy to disassemble for cleaning.
- Removable crumb drawer.
- 2 grills in chrome steel are included.
- Fast and efficient quartz heaters.
- Perfect to heat up pizza, sandwiches and pre-cooked foodstuffs; to toast bruschetta bread, hamburgers, hot dogs, stuffed toasts and piadina bread, and also king shrimps, sardines, vegetables and any product you need to toast fast and with marked grill lines.

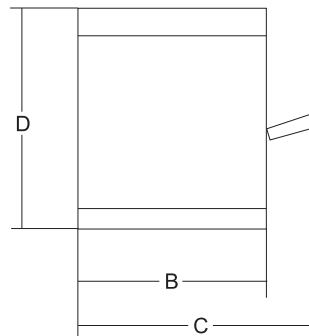
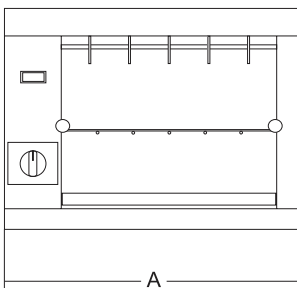

	Potenza Power Spannung Puissance	Alimentazione Power source Betriebsspannung Alimentation	Zone riscaldanti Heating areas Heizzone Zones chauffant	Dimensioni interne Internal dimensions Innenmaße Dimensions intérieures	Dimensioni vano cottura Cooking compartment dim. Oberfläche Dimensions module de cuisson	A	B	C	D	Peso netto Net weight Nettogewicht Poids net	Dimensioni imballo Shipping Verpack. abmessungen Dim. emballage	Peso lordo Gross weight Brutogewicht Poids brut
	Watt	n.	mm	mm	mm	mm	mm	mm	mm	Kg	mm	kg
Tostone	3600	230V 50/60 Hz F+N	3	450x350 h.290	(450x330 h.85) x2	525	380	392	365	12	670x450x480	16
	Potencia Potência Мощность 功率	Alimentación Alimentação Электропитание 电源	Zonas calentadoras Zonas aquecimento Зоны нагрева 加热区	Dimensiones internas Dimensões internas Внутренние размеры 内部尺寸	Dimensiones del espacio de cocción Dimensões espaço cozimento Размеры зоны выпекания 烹饪区直径	A	B	C	D	Peso netto Peso líquido Вес нетто 净重	Dimensiones embalaje Dimensões embalagem Размеры упаковки 包装尺寸	Peso bruto Peso bruto Вес брутто 毛重



TO STÌ, BREAKFAST, LONG, BRUSCHETTA

roller toast
conveyor toasters



ROLLER TOSTÌ 18 VV



1. Protezione comandi (opzionale)
Controls protection (optional)

TOSTÌ 18 VV

- Costruito interamente in acciaio inox AISI 304.
- Tappeto per la tostatura in acciaio AISI 304.
- Motore auto-ventilato.
- Ventilatore tangenziale per raffreddare il mantello esterno per evitare le scottature.
- Resistenze corazzate per una lunga durata.
- Riflettente su resistenze per una maggiore resa.
- Possibilità di selezionare il funzionamento delle resistenze.
- Scivoli di carico e scarico prodotto.
- Chiusura posteriore ribaltabile per consentire lo scarico frontale o posteriore.
- Motore con velocità variabile.

ROLLER TOAST BREAKFAST - LONG - BRUSCHETTA

- Facili e pratici da usare sono adatti per tostare e riscaldare crostini, bruschette, pizzette, patate, briocche e stuzzichini vari.
- Costruiti interamente in acciaio inox AISI 304 e tappeto per la tostatura in acciaio AISI 304.
- Camera di cottura con isolamento termico.
- Motore auto-ventilato.
- Vano comandi con ventola di raffreddamento per i componenti elettrici.
- Tubi al quarzo, con funzionamento modulare.
- Variatore di velocità nelle versioni VV.
- Scivoli di carico e scarico prodotto.
- Cassetto di raccolta briciole facilmente estraibile.
- Chiusura posteriore ribaltabile per consentire lo scarico frontale o posteriore del prodotto (no per il Roller Breakfast).



ROLLER BREAKFAST

TOSTÌ 18 VV

- AISI 304 stainless steel construction including conveyor.
- Fan-cooled motor.
- Built-in cooling-fan to prevent overheating and burns.
- Reinforced heating elements against burnout and breakage.
- Reflecting heating elements for upper and lower heat ensure that the product is quickly and evenly heated.
- Upper and lower elements can be selected for perfect golden toasting every time.
- Easy-to-load rack with rear or front discharge.
- Variable speed motor.

ROLLER TOAST BREAKFAST - LONG AND BRUSCHETTA

- Easy to use and suitable for toasting or heating up bread, bruschetta, pizza, croissants, french fries and many other snacks.
- Made from AISI 304 S/S with AISI 304 S/S conveyor belt.
- Thermal insulation of the chamber.
- Self-ventilated motor.
- Fan cooled controls compartment.
- The heating elements covered by quartz tubes can be switched on independently.
- Variable speed drive. (VV versions)
- Loading and unloading chutes.
- Easy to remove crumb pan.
- Tilting back closing plate allows rear delivery of the product (not on Roller Breakfast).



ROLLER LONG VV



ROLLER BRUSCHETTA

ROLLER

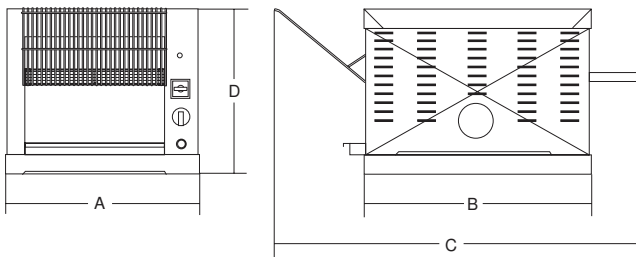

TOSTI

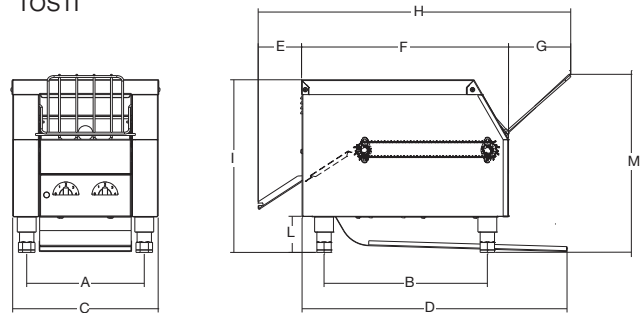

Roller Long VV

X = fette / toast cm 8x8
Y = fette / toast cm 9x9

	Potenza Power Spannung Puissance	Alimentazione Power source Betriebsspannung Alimentation	Produzione oraria Output/h. Leistung/h. Débit/h.	Larghezza tappelo Width conveyor grid Breite Backklange Largeur tapis de cuisson	Lunghezza tappelo Length conveyor grid Breite Banntzeitel Longueur tapis de cuisson	A	B	C	D	E	F	G	H	I	L	M	Peso netto Net weight Nettogewicht Poids net	Dimensioni imballo Shipping Verpack. abmessungen Dim. emballage	Peso lordo Gross weight Bruttogewicht Poids brut
	Watt	n.	mm	mm	mm	mm	mm	mm	mm	mm	mm	mm	mm	mm	mm	mm	Kg	mm	kg
Tosti 18 VV	1300	230V 50 Hz F+N	min. 65 max 360	185	500	238	330	294	535	88	418	126	632	349	73	360	12	670x450x480	14
Roller Breakfast	2660	230V 50 Hz F+N	200	220	330	370	480	630	340	-	-	-	-	-	-	-	16	450x660x440	18,5
Roller Breakfast VV	2660	230V 50 Hz F+N	80÷360	220	330	370	480	630	340	-	-	-	-	-	-	-	16	450x660x440	18,5
Roller Long	3000	230V 50/60 Hz F+N	410	305	410	430	530	870	360	-	-	-	-	-	-	-	22	720x540x480	27
Roller Long VV	3000	230V 50/60 Hz F+N	X = 165÷525 Y = 132÷420	305	410	430	530	870	360	-	-	-	-	-	-	-	22	720x540x480	27,5
Roller Bruschetta VV	3000	230V 50/60 Hz F+N	75÷230	305x2	410x2	450	535	1270	560	-	-	-	-	-	-	-	27	860x550x500	29

Potencia
Potência
Мощность
功率

Alimentación
Alimentação
Электропитание
电源

Producción/h.
Produção/h.
Производительность
产量/小时

Ancho de la rejilla transportadora
Largura grade transportadora
Ширины ленты
烤盘的宽度

Longitud de la rejilla transportadora
Comprimento grade transportadora
Длина ленты
烤盘长度

A

B

C

D

E

F

G

H

I

L

M

Peso netto
Peso líquido
Вес нетто
净重

Dimensiones embalaje
Dimensões embalagem
Размеры упаковки
包装尺寸

Peso bruto
Peso bruto
Вес брутто
毛重



VISTA

vetrinette brioches pastry display cabinets

- Vetrinette per l'esposizione ed il mantenimento di alimenti come brioches, dolci e stuzzichini
- Disponibile in 1 o 2 piani
- Piani d'appoggio estraibili in acciaio inox
- Basamento in alluminio perfettamente liscio per una facile pulizia
- Struttura in plexiglas trasparente e profili di alluminio anodizzato
- 2 porte apribili verticalmente.

- Case for displaying and storing croissants, cakes and other snacks
- Available with 1 or 2 levels
- S/S extractable product holding surfaces
- Aluminium, perfectly smooth base easy to clean
- Transparent plexiglas structure and anodised aluminium profiles
- 2 vertically openable doors.



VISTA P2 BRIOCHES

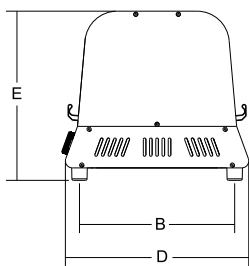
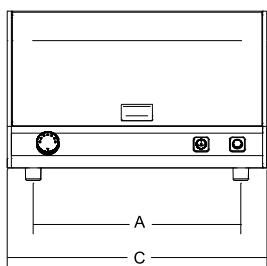

Vista Brioches:

- Disponibile anche nella versione calda con termostato regolabile.
- Riscaldamento a bassa temperatura per evitare di seccare il prodotto

Vista Hot:

- Termostato regolabile.
- Vaschetta d'acqua per il mantenimento dell'umidità.

Vista Brioches:

- Available even in the hot version with adjustable thermostat.
- Heating at low temperatures to avoid drying the product

Vista Hot:

- Adjustable thermostat.
- Water tank to maintain humidity.

	Potenza Power Sonnung Puissance	Alimentazione Power source Betriebsspannung Alimentation	Temperatura Temperature Temperatur Temperature	Dim. piano inferiore 1st level dimensions 1 Stock Abmessungen Dim. première surface	Dim. piano superiore 2nd level dimensions 2er Stock Abmessungen Dim. deuxième surface	A	B	C	D	E	Peso netto Net weight Nettogewicht Poids net	Dimensioni imballo Shipping Verpack. abmessungen Dim. emballage	Peso lordo Gross weight Bruttogewicht Poids brut
	Watt		°C	mm	mm	mm	mm	mm	mm	mm	Kg	mm	kg
Vista P1N	-	-	-	480x290	-	400	300	500	355	325	7	620x430x350	11
Vista P1 Brioches	300	230V 50/60 Hz F+N	max 40	480x290	-	400	300	500	355	325	8	620x430x350	12
Vista P1 Hot	450	230V 50/60 Hz F+N	max 70	480x290	-	400	300	500	355	325	8	620x430x350	12
Vista P2N	-	-	-	480x290	480x265	400	300	500	355	405	9	620x430x450	13
Vista P2 Brioches	300	230V 50/60 Hz F+N	max 40	480x290	480x265	400	300	500	355	405	10	620x430x450	14
Vista P2 Hot	450	230V 50/60 Hz F+N	max 70	480x290	480x265	400	300	500	355	405	10	620x430x450	14

Potencia
Potência
Мощность

Alimentación
Alimentação
Электропитание
電源

Temperatura
Temperatura
Температура
温度

Dimensiones primer plano
Dimensões do primeiro andar
Размеры в первом этаже
第一层面尺寸

Dimensiones segundo plano
Dimensões do segundo andar
Размеры в втором этаже
第二层面尺寸

A

B

C

D

E

Peso netto
Peso líquido
Вес нето
净重

Dimensiones embalaje
Dimensões embalagem
Размеры упаковки
包装尺寸

Peso bruto
Peso bruto
Вес брутто
毛重



VISTA P1 BRIOCHES



VISTA P1N



VISTA P2N



VISTA BOLD

vetrinette brioches pastry display cabinets

- Vetrinette per l'esposizione ed il mantenimento di alimenti come brioches, dolci e stuzzichini.
- Struttura in plexiglas trasparente e profili di alluminio anodizzato.
- Piani d'appoggio estraibili in acciaio inox.
- 2 porte apribili verticalmente.
- Led di illuminazione opzionali da 20 watt.

Vista Bold Brioches:

- Disponibile anche nella versione calda con termostato regolabile.
- Riscaldamento a bassa temperatura per evitare di seccare il prodotto.

Vista Bold Hot:

- Disponibile anche nella versione calda con regolazione fino a 70° C.
- Vaschetta d'acqua per il mantenimento dell'umidità.

- *Case for displaying and storing croissants, cakes and other snacks.*
- *Transparent plexiglas structure and anodised aluminium profiles.*
- *S/S extractable product holding surfaces.*
- *2 vertically openable doors.*
- *Optional lighting LED, 20 watt.*

Vista Bold Brioches:

- Available even in the hot version with adjustable thermostat.
- Heating at low temperatures to avoid drying the product.

Vista Bold Hot:

- Available even in the hot version with adjustable thermostat up to 70° C.
- Water tank to maintain humidity.



VISTA P2 BOLD

VISTA P3 BOLD HOT LED



VISTA P3 BOLD HOT LED

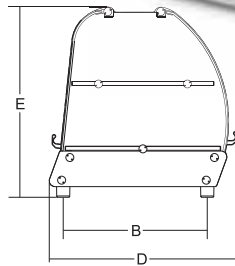
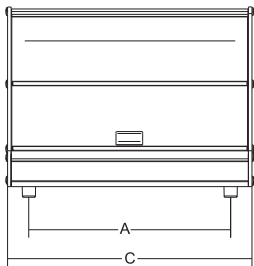

Potenza
Power
Potência
Spamung
Puissance

Allimentazione
Power source
Potência
Betriebsspannung
Alimentation

Temperatura
Temperature
Temperatura
Temperatura
Temperature

Dim. 1° piano
1st level dimensions
1. Stock Abmessungen
Dim. première surface

Dim. 2° piano
2nd level dimensions
2. Stock Abmessungen
Dim. deuxième surface

Dim. 3° piano
3rd level dimensions
3. Stock Abmessungen
Dim. troisième surface

A

B

C

D

E

Peso netto
Net weight
Nettogewicht
Poids net

Dimensioni imballo
Shipping
Verpack. abmessungen
Dim. emballage

Peso lordo
Gross weight
Bruttogewicht
Poids brut

	Watt		°C	mm	mm	mm	mm	mm	mm	mm	Kg	mm	kg	
Vista P2 Bold	-	-	-	530x356	530x320	-	450	325	550	405	425	13	660x500x470	17
Vista P2 Bold Brioches	300	230V 50/60 Hz F+N	max 40	530x356	530x320	-	450	325	550	405	425	15	660x500x470	19
Vista P2 Bold Hot	450	230V 50/60 Hz F+N	max 70	530x356	530x320	-	450	325	550	405	425	15	660x500x470	19
Vista P3 Bold	-	-	-	530x356	530x350	530x300	450	325	550	405	565	14	660x500x610	18
Vista P3 Bold Brioches	300	230V 50/60 Hz F+N	max 40	530x356	530x350	530x300	450	325	550	405	565	16	660x500x610	20
Vista P3 Bold Hot	450	230V 50/60 Hz F+N	max 70	530x356	530x350	530x300	450	325	550	405	565	16	660x500x610	20

Potencia
Potência
Mощность
功率

Allimentação
Alimentação
Электронитание
电源

Temperatura
Temperatura
Temperatura
温度

Dimensiones primer plano
Dimensions do primeiro andar
Размеры первого этажа
第一层尺寸

Dimensiones segundo plano
Dimensions do segundo andar
Размеры второго этажа
第二层尺寸

Dimensiones tercer plano
Dimensions do terceiro andar
Размеры третьего этажа
第三层尺寸

A

B

C

D

E

Peso netto
Peso líquido
Bec NETTO
淨重

Dimensiones e embalaje
Dimensões embalagem
Размеры упаковки
包裝尺寸

Peso bruto
Peso bruto
Bec БРУТТО
毛重



VISTA TO WER

vetrinette brioches pastry display cabinets

- Vetrinette per l'esposizione ed il mantenimento di alimenti come brioches, dolci e stuzzichini
- Struttura in plexiglas trasparente e profili di alluminio anodizzato
- Piani d'appoggio estraibili in acciaio inox
- Led di illuminazione opzionali da 20 watt.

Vista Tower Hot:

- Disponibile anche nella versione calda con regolazione fino a 70° C.
- Vaschetta d'acqua per il mantenimento dell'umidità.

- Case for displaying and storing croissants, cakes and other snacks
- Transparent plexiglas structure and anodised aluminium profiles
- S/S extractable product holding surfaces
- Optional lighting LED, 20 watt.

Vista Tower Hot:

- Available even in the hot version with adjustable thermostat up to 70° C.
- Water tank to maintain humidity.



VISTA TOWER HOT LED



VISTA TOWER LED

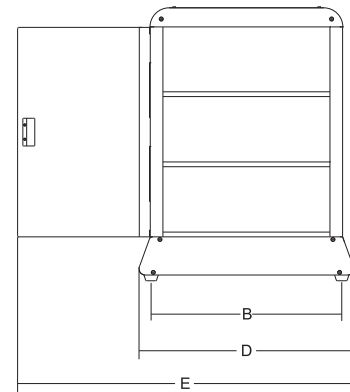
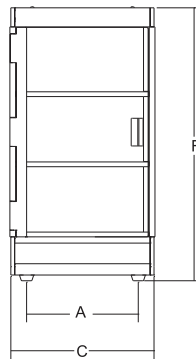

	Potenza Power Spannung Puissance	Alimentazione Power source Betriebsspannung Alimentation	Temperatura Temperature Temperatur Température	Dim. piano inferiore 1st level dimensions 1 Stock Abmessungen Dim. première surface	Dim. piano superiore 2nd level dimensions 2en Stock Abmessungen Dim. deuxième surface	A	B	C	D	E	F	Peso netto Net weight Nettogewicht Poids net	Dimensioni imballo Shipping Verpack abmessungen Dim. emballage	Peso lordo Gross weight Bruttogewicht Poids brut
	Watt	°C	mm	mm	mm	mm	mm	mm	mm	mm	mm	Kg	mm	kg
Vista Tower	-	-	-	280x380	280x380	234	400	300	450	705	570	13	380x510x625	15
Vista Tower Hot	450	230V 50/60 Hz F+N	max 70	280x380	280x380	234	400	300	450	705	570	14	380x510x625	16
	Potencia Potência Мощность 功率	Alimentação Alimentação Электропитание 電源	Temperatura Temperature Temperatura 温度	Dimensiones primer plano Dimensões do primeiro andar Размеры первого этаже 第一层尺寸	Dimensiones segundo plano Dimensões do segundo andar размеры второго этаже 第二层尺寸	A	B	C	D	E	F	Peso netto Peso líquido Вес-нетто 净重	Dimensiones embalaje Dimensões embalagem Размеры упаковки 包装尺寸	Peso bruto Peso bruto Вес брутто 毛重



NIGHT & DAY

vetrinetta e piastra buffet

display cabinet and buffet plate



- Piastra da buffet sia calda che fredda.
- Grande praticità e versatilità con ingombro minimo.
- Piano di appoggio in alluminio anodizzato.
- Corpo in acciaio inox.
- Invertitore caldo-off-freddo.
- Pratico termometro digitale di controllo.
- Sistema raffreddante/riscaldante con modulo termoelettrico a basso consumo (70Watt).
- Può essere affiancata in modo continuo.
- Piedini regolabili.

- *Hot and cold plate for buffet.*
- *Easy and practical to use with minimum overall dimensions.*
- *Anodized aluminium holding surface.*
- *Stainless steel body.*
- *Hot - off - cold switch positions.*
- *Digital thermometer for temperature control.*
- *Heating and cooling system based on energy saving thermo-electric module. (70 watt)*
- *The plates can be placed side by side.*
- *Adjustable feet.*

VISTA NIGHT & DAY

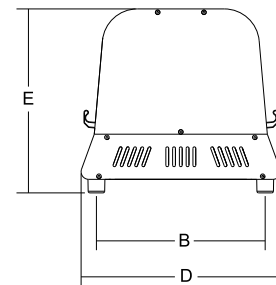
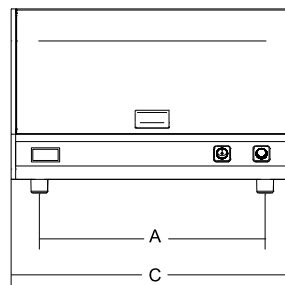
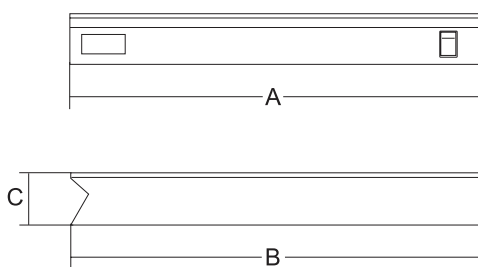

	Potenza Power Spannung Puissance	Alimentazione Power source Betriebsspannung Alimentation	Temperatura Temperature Temperatur Température	Sup. utile Useful surface Nutzfläche Surface utile	A	B	C	D	E	Peso netto Net weight Nettogewicht Poids net	Dimensioni imballo Shipping Verpack abmessungen Dim. emballage	Peso lordo Gross weight Bruttogewicht Poids brut
	Watt		°C	mm	mm	mm	mm	mm	mm	Kg	mm	kg
Night & Day	70	230V/50Hz	+8 + +70	350 x 350	350	380	100	-	-	7	410x440x215	8
Vista Night & Day	70	230V/50Hz	+8 + +50	480 x 290	400	300	500	355	325	9	620x430x350	13

Potencia
Potência
Мощность
功率

Alimentación
Alimentação
Электропитание
電源

Temperatura
Temperatura
Температура
温度

Superficie útil
Superficie útil
Полезная площадь
有用表面

A B C D E

Peso netto
Peso líquido
Вес нетто
淨重

Dimensiones embalaje
Dimensões embalagem
Размеры упаковки
包裝尺寸

Peso bruto
Peso bruto
Вес брутто
毛重





VISTA EASYCOLD

vetrinette refrigerate
refrigerated display cabinets



- Struttura in alluminio anodizzato con inserti in acciaio inox.
- Ante in plexiglass trasparente antiurto con apertura su entrambi i lati.
- Vasca stagna refrigerata in acciaio inox.
- Temperatura min. 3° C.
- Termostato digitale con visualizzatore temperatura.
- Led di illuminazione opzionali.
- Vaschette non comprese.

Easycold 100

- 2 vaschette 1/2 gastronorm h. 40 mm
- 4 vaschette 1/4 gastronorm h. 40 mm

Easycold 130

- 3 vaschette 1/2 gastronorm h. 40 mm
- 6 vaschette 1/4 gastronorm h. 40 mm

- Structure in anodized aluminum with inserts in stainless steel.
- Doors in transparent collision-proof Plexiglas that open on both sides.
- Airtight tank in stainless steel.
- Min. temperature 3° C.
- Digital thermal switch with temperature display.
- Optional lighting LED.
- Trays not included.

Easycold 100

- 2 trays 1/2 gastronorm h. 40 mm
- 4 trays 1/4 gastronorm h. 40 mm

Easycold 130

- 3 trays 1/2 gastronorm h. 40 mm
- 6 trays 1/4 gastronorm h. 40 mm

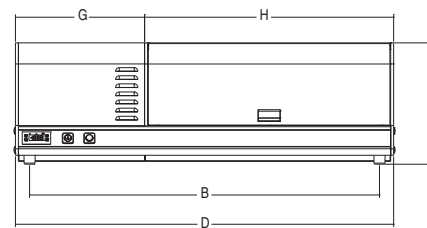
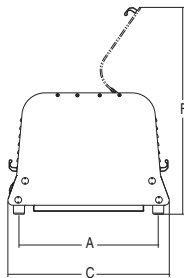

Potenza
Power
Spannung
Puissance

Alimentazione
Power source
Betriebsspannung
Alimentation

Temperatura
Temperature
Temperatur
Temperatures

A

B

C

D

E

F

G

H

Peso netto
Net weight
Nettogewicht
Poids net

Dimensioni imballo
Shipping
Verpack. abmessungen
Dim. emballage

Peso lordo
Gross weight
Bruttogewicht
Poids brut

	Watt	230V 50/60 Hz	°C	mm	mm	mm	mm	mm	mm	mm	mm	Kg	mm	kg
Vista Easycold 100	150	230V 50/60 Hz	min. 3	374	870	434	950	220	395	280	670	28	500x1200x600	30
Vista Easycold 130	150	230V 50/60 Hz	min. 3	374	1200	434	1280	220	395	280	1000	33	500x1400x600	35

Potencia
Potencia
Мощность
功率

Alimentación
Alimentação
Электроснабжение
電源

Temperatura
Temperatura
Temperatura
温度

A

B

C

D

E

F

G

H

Peso netto
Peso líquido
Вес нетто
淨重

Dimensiones embalaje
Dimensões embalagem
Размеры упаковки
包裝尺寸

Peso bruto
Peso bruto
Вес брутто
毛重



VISTA EASYCOLD 100



VISTA EASYCOLD 130



GW

girawürstel hot dog warmer



GW5

- Girawürstel a rulli, ideale per paninoteche, snack-bars, fast-foods. Cuoce in modo rapido e uniforme, würstel e salsicce che acquistano così il sapore e la colorazione tipici della cottura alla griglia senza che sia necessario rigirarli manualmente.
 - Realizzato in lamiera di acciaio inox.
 - Motore asincrono con riduttore di velocità ad ingranaggi.
 - Spalle laterali che sostengono i rulli in acciaio inox contenenti delle resistenze corazzate.
 - Opzionale: GW con rulli teflonati.
- The roller-type wurstel heater is ideal in fast-food retailers, bars and pubs. It allows a fast and even cooking of wurstels and sausages which will get the taste and the browning of grilled meat without having to turn them over manually.*
- Made from stainless steel body.
 - Asynchronous motor with gear-box reducer.
 - S/S rolls with shock-proof heating elements.
 - Optional: teflon-coated rolls.

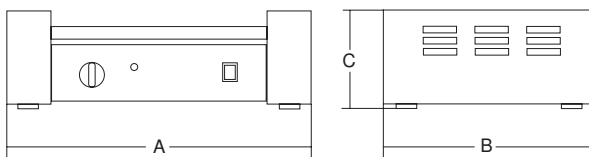

	Potenza Power Spannung Puissance	Alimentazione Power source Betriebsspannung Alimentation	Numero rulli Rollers number Rollen Zahl Nombre rouleaux	Lunghezza rulli Rollers length Rollen länge Longueur rouleaux	Ø Rulli Ø Rollers Ø Rollenbreite Ø Rouleaux	A	B	C	Peso netto Net weight Nettogewicht Poids net	Dimensioni i imballo Shipping Verpack abmessungen Dim. emballage	Peso lordo Gross weight Bruttogewicht Poids brut
	Watt		n.	mm	mm	mm	mm	mm	Kg	mm	kg
GW5	850	230V/50Hz	5	350	25	450	230	170	7,5	550x400x260	8,5
GW7	1400	230V/50Hz	7	460	25	560	300	170	11	700x480x240	12
GW9	1650	230V/50Hz	9	460	25	560	375	180	13	700x480x240	14,5

Potencia
Potência
Мощность
功率

Alimentación
Alimentação
Электропитание
電源

Numero de rodillos
Número rolos
Кол-во роликов
滚筒数

Longitud rodillos
Comprimento rolos
Длина ванков
滚筒长

Ø Rodillos
Ø Roños
Ø роликов
滚筒直径

A B C

Peso neto
Peso líquido
Вес нетто
淨重

Dimensiones embalaje
Dimensões embalagem
Размеры упаковки
包裝尺寸

Peso bruto
Peso bruto
Вес брутто
毛重



GW7



GW9



HOT DOG - ROBERTO

scaldawürstel e scaldapane
hot dog warmers and bread warm

HOT DOG

- Contenitore in pirex per la cottura del wurstel.
- Cesto di contenimento wurstel in acciaio inox.
- Regolazione della potenza con simostato.
- Componenti elettrici auto-protetti da eventuali perdite di liquidi.
- Riscaldatori pane in alluminio anodizzato.

ROBERTO

- Regolazione della potenza tramite simostato.
- Componenti elettrici auto-protetti da eventuali perdite di liquidi.
- Riscaldatori pane in alluminio anodizzato.

HOT DOG

- Pyrex container for steaming hot dogs.
- Stainless steel basket for hot dogs.
- Heating up controlled by a symostat.
- Sealed electric components protected against leaks.
- Anodized aluminium bun warmers.

ROBERTO

- Heating up controlled by a symostat.
- Sealed electric components protected against leaks.
- Anodized aluminium bun warmers.



HOT DOG 3

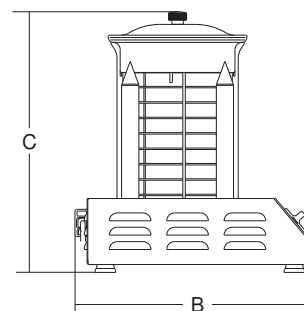
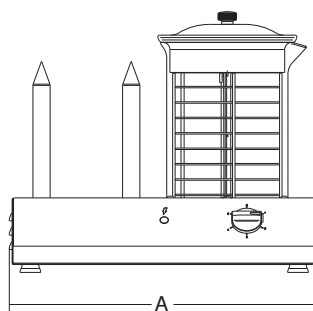

	Potenza Power Spannung Puissance	Alimentazione Power source Betriebsspannung Alimentation	Riscaldatori pane Bread heaters Heizung brot Chaufage pain	Dim. Cestello Size of basket Korbabmessungen Dimensions panier	Capacità wurstel Wurstel capacity Wurstel Kapazität Capacité wurstel	A	B	C	Peso netto Net weight Nettogewicht Poids net	Dimensioni imballo Shipping Verpack abmessungen Dim. emballage	Peso lordo Gross weight Bruttogewicht Poids brut
	Watt	n.	mm	n.	mm	mm	mm	mm	Kg	mm	kg
Hot Dog 3	600	230V 50/60 Hz F+N	3	ø 152xh. 194	30	450	320	365	9,5	500x370x500	11
Hot Dog 4	600	230V 50/60 Hz F+N	4	ø 152xh. 194	30	450	320	365	10	500x370x500	11,5
Roberto	875	230V 50/60 Hz F+N	6	-	-	450	320	294	8	500x370x500	9,5

Potencia
Potência
Мощность
功率

Alimentación
Alimentação
Электропитание
电源

Calentador pan
Aquecedor pan
Штыри погрелва
面包加热机

Dimensión cesta
Dimensão cesta
Размеры корзины
篮的尺寸

Capacidad salchicha
Capacidade salchicha
Кон-во сосисок
烤香肠容量

A B C

Peso netto
Pésu líquido
Вес нетто
净重

Dimensiones embalaje
Dimensões embalagem
Размеры упаковки
包装尺寸

Peso bruto
Pésu bruto
Вес брутто
毛重



HOT DOG 4



SCALDAPAN E ROBERTO



TW 6

TW tagliawürstel würstelcutter

Tagliawürstel manuale in acciaio inox, semplice da usare e da pulire.

Taglia con facilità würstel, uova, pomodori, peperoni; basta infatti appoggiare il prodotto sulle lame e abbassare il coperchio fino alla sua completa chiusura, e le fettine cadranno automaticamente nella vaschetta sottostante, già pronte per essere utilizzate.

Manual stainless steel würstelcutter, easy to use and to clean. It cuts easily wurstels, eggs, tomatoes, peppers: you just need to put the product on the blades, then to pull down the lid to its complete closure and the slices will fall down into the container below, ready to be used.

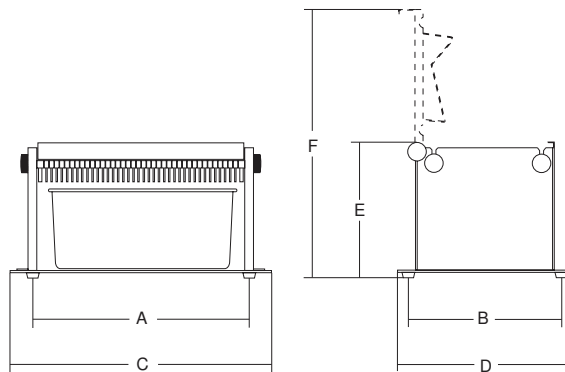

Distancia lame
Blades space
Abst. zwischen Messer
Ecartem. des lames

Lame
Blades
Messer
Lames

A B C D E F

Peso neto
Net weight
Nettogewicht
Poids net

Dimensioni imballo
Shipping
Verpack. abmessungen
Dim. emballage

Peso lordo
Gross weight
Bruttogewicht
Poids brut

	mm	n.	mm	mm	mm	mm	mm	mm	Kg	mm	kg
TW 6	6	34	240	160	280	170	170	270	2,5	320x210x220	3
TW 12	12	17	240	160	280	170	170	270	2,5	320x210x220	3

Distancia entre cuchillas
Distância entre as lâminas
Расстояние между лезвиями
刀片间距

Cuchillas
Lâminas
刀片
кол-во лезвий

A B C D E F

Peso neto
Peso líquido
Вес нето
净重

Dimensiones embalaje
Dimensões embalagem
Размеры упаковки
包装尺寸

Peso bruto
Peso bruto
Вес брутто
毛重



HERCULES 5-10-15

impastatrici pizza *dough mixers*



- Struttura in acciaio a grosso spessore.
- Verniciatura antigraffio a polveri epossidiche alimentare.
- Vasca con bordo rinforzato e asta rompi pasta in acciaio AISI 304.
- Spirale forgiata.
- Coperchio vasca conforme alle normative.
- Motore potente e ventilato.
- Trasmissione moto interno con catena rinforzata.
- Comandi a bassa tensione resistenti IP 67.
- Disponibile versione con timer a richiesta per i mod. 10-15.

- *Made from large thickness steel.*
- *Scratch resistant powder coating.*
- *Bowl with reinforced edge and AISI 304 S/S shaft.*
- *Forged spiral tool.*
- *Container lid conforms to regulations.*
- *High efficiency ventilated motor.*
- *Reinforced chain drive.*
- *Low voltage IP67 protection rated controls.*
- *On request timer version for mod. 10-15.*



HERCULES 10
1. Timer opzionale
Optional timer



HERCULES 5



HERCULES 15





2. Coperchio vasca conforme alle normative
Container lid conform to regulations



3. Coperchio sollevabile
Lifttable lid



4. Asta rompipasta
Shaft



5. Comandi con timer opzionale
Controls with optional timer

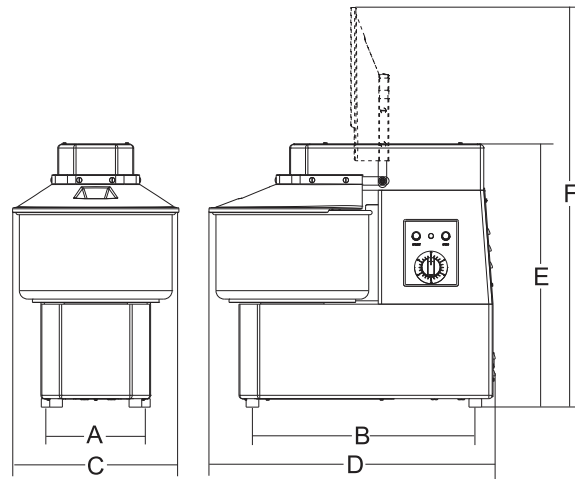

	Potenza Power Spannung Puissance	Alimentazione Power source Betriebsspannung Alimentation	Giri vasca - spirale Revolutions tank - spiral Umdrehungen Becken - Spirale Tours cuve - spirale	Capacità vasca Tank capacity Beckenkapazität Cuve capacité	Capacità impasto Dough capacity Teig Kapazität Capacité pâte	Dimensioni vasca Tank dimensions Beckenabmessungen Dimensions cuve	A	B	C	D	E	F	Peso netto Net weight Nettogewicht Poids net	Dimensioni imballo Shipping Verpack abmessungen Dm. emballage	Peso lordo Gross weight Bruttogewicht Poids brut
	watt/Hp		r.p.m.	lt	kg	mm	mm	mm	mm	mm	mm	mm	Kg	mm	kg
Hercules 5	370/0,5	230V/50Hz	13 - 83	7	4	Ø 265x140	220	410	280	505	440	670	36	500x630x650	42
Hercules 10	370/0,5	230-380V/50Hz	13 - 83	12	8	Ø 280x190	250	490	305	580	560	825	44	570x720x700	54
Hercules 15	550/0,75	230-380V/50Hz	13 - 83	16	12	Ø 320x200	250	500	340	590	560	850	48	570x720x700	58
	Potencia Potência Мощность 功率	Alimentación Alimentação Электроснабжение 电源	Vueltas tina - espiral Giros recipiente - espiral Центрнам револуции - спираль 車命型見 - 螺旋	Capacidad tina Capacidade recipiente Объем бункера 容器容積	Capacidad masa Capacidade da massa de pão Пецо потенциала 面团重量	Dimensiones cuba Dimensão cuba Размере ваенны 攪拌桶容積	A	B	C	D	E	F	Peso netto Peso líquido Bec netto 淨重	Dimensiones embalaje Dimensões embalagem Размеры упаковки 包裝尺寸	Peso bruto Peso bruto Bec брутто 毛重



HERCULES 20-30-40-50

impastatrici pizza dough mixers



- Struttura in acciaio C40 a grosso spessore.
- Verniciatura antigraffio a polveri epossidiche alimentare.
- Vasca con bordo rinforzato e asta rompi pasta in acciaio AISI 304.
- Spirale forgiata.
- Coperchio vasca conforme alle normative con foro per aggiunta prodotto in lavorazione.
- Motore potente e ventilato con riduttore a vite senza fine a bagno d'olio.
- Protezione termica motore.
- Trasmissione moto interno con catena rinforzata.
- Comandi a bassa tensione resistenti IP 67.
- Ruote, timer e coperchio griglia opzionali.
- Disponibile a 2 velocità su richiesta.

VERSIONE TA:

- Testa sollevabile.
- Vasca asportabile.

- *Made from large thickness C40 steel.*
- *Scratch resistant powder coating.*
- *Bowl with reinforced edge and AISI 304 S/S shaft.*
- *Forged spiral tool.*
- *Lid with opening to add ingredients during operation.*
- *High efficiency ventilated motor with oil-bath gear box.*
- *Thermal overload protection circuit breaker*
- *Reinforced chain drive.*
- *Low voltage IP67 protection rated controls.*
- *Optionals: wheels, timer and grill cover.*
- *On request 2 speed version.*

TA VERSION:

- *Liftable head for tank removal and easy clearing.*
- *Removable container.*



HERCULES
1. Timer opzionale
Optional timer

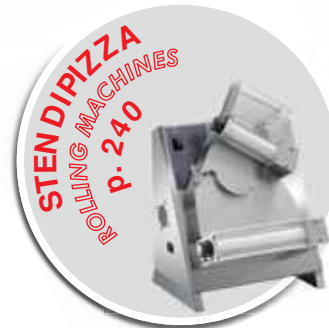

HERCULES TA



2. Coperchio griglia e ruote opzionali
Optionals grill cover and wheels

3. Timer opzionale
Optional timer



4. Coperchio con foro per aggiunta prodotto
Lid with opening to add ingredients



5. Testa sollevabile
Liftable head



6. Asta rompipasta
Shaft



7. Comandi con timer opzionale
Controls with optional timer



8. Comandi 2V
Controls 2V

HERCULES

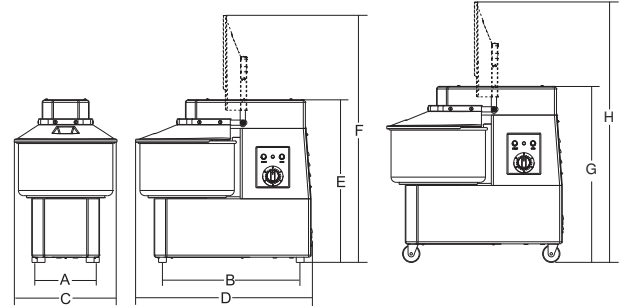

HERCULES TA

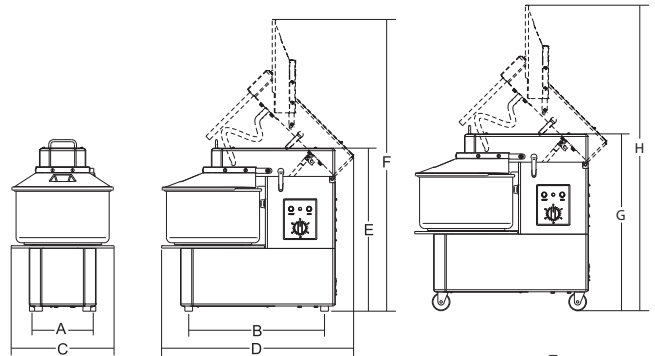

Potenza Power Spannung Puissance
Alimentazione Power source Betriebsspannung Alimentation
Giri vasca - spirale Revolutions tank - spiral Umdrehungen Becken - Spirale Tours cuve - spirale
Capacità vasca Tank capacity Becken kapazität Cuve capacité
Capacità impasto Dough capacity Teig Kapazität Capacité pâte
Dimensioni vasca Tank dimensions Becken abmessungen Dimensions cuve
Peso netto Net weight Nettogewicht Poids net
Dimensioni imballo Shipping Verpack. abmessungen Dim. emballage
Peso lordo Gross weight Bruttogewicht Poids brut

	watt/Hp	r.p.m.	lt	kg	mm	A	B	C	D	E	F	G	H	Kg	mm	kg	
Hercules 20B	750/1	230-400V/50Hz	10 - 85	21	17	ø 360x210	230	530	390	680	625	950	705	1030	66	530x830x1020	76
Hercules 20	750/1	230-400V/50Hz	10 - 85	21	17	ø 360x210	230	530	390	680	625	950	705	1030	70	530x830x1020	80
Hercules 30	1100/1,5	230-400V/50Hz	10 - 85	32	25	ø 400x260	270	590	440	740	700	1050	780	1130	95	530x830x1020	105
Hercules 40	1500/2	230-400V/50Hz	10 - 85	41	35	ø 452x260	310	660	480	825	730	1135	810	1215	105	630x970x1070	115
Hercules 50	1500/2	230-400V/50Hz	10 - 85	52	44	ø 500x270	310	680	540	880	750	1205	830	1285	118	630x970x1070	128
Hercules 20 2V	750-1100/ 1-1,5	230-400V/50Hz	1V=10 - 85 2V=20 - 170	21	17	ø 360x210	230	530	390	680	625	950	705	1030	65	530x830x1020	75
Hercules 30 2V	1300-1700/ 1,8-2,3	230-400V/50Hz	1V=10 - 85 2V=20 - 170	32	25	ø 400x260	270	590	440	740	700	1050	780	1130	95	530x830x1020	105
Hercules 40 2V	1500-2200/ 2-3	230-400V/50Hz	1V=10 - 85 2V=20 - 170	41	35	ø 452x260	310	660	480	825	730	1135	810	1215	105	630x970x1070	115
Hercules 50 2V	1500-2200/ 2-3	230-400V/50Hz	1V=10 - 85 2V=20 - 170	52	44	ø 500x270	310	680	540	880	750	1205	830	1285	118	630x970x1070	128
Hercules 20 TA	750/1	230-400V/50Hz	10 - 85	21	17	ø 360x210	230	530	400	751	635	1125	715	1205	88	530x830x1020	98
Hercules 30 TA	1100/1,5	230-400V/50Hz	10 - 85	32	25	ø 400x260	270	590	440	823	710	1260	790	1340	109	530x830x1020	119
Hercules 40 TA	1500/2	230-400V/50Hz	10 - 85	41	35	ø 452x260	310	660	490	910	740	1360	820	1440	125	630x970x1070	135
Hercules 50 TA	1500/2	230-400V/50Hz	10 - 85	52	44	ø 500x270	310	680	540	970	795	1415	875	1495	118	630x970x1070	128

Potencia Potência Мощность 功率
Alimentación Alimentação Электропитание 电源
Vueltas/tina - espiral Giros/respirante - espiral Цистернам/революций - спираль 革命坦克 - 螺旋
Capacidad tina Capacidade recipiente Объем бункера 容器容积
Capacidad masa Capacidade de massa de pão Тесто потенциала 面团容量
Dimensiones cuba Dimensão cuba Размеры ванны 搅拌箱容积
Peso neto Peso líquido Вес нетто 净重
Dimensiones embalaje Dimensiones embalagem Размеры упаковки 包装尺寸
Peso bruto Peso bruto Вес брутто 毛重



PIASTRA SCALDAPIZZA

piastra scaldapizza pizza warmers

- Struttura robusta e compatta.
- Costruita interamente in acciaio inox AISI 340.
- Resistenze corazzate protette contro gli impatti accidentali.
- Temperatura regolabile con termostato da 0 a 60 °C
- Spia luminosa per segnalazione rete.

- *Sturdy and compact structure.*
- *Made from AISI 340 stainless steel.*
- *Shock-proof heating elements.*
- *Temperature adjustable by means of a thermostat from 0 to 60°C*
- *Pilot light.*



PIASTRA SCALDAPIZZA INOX

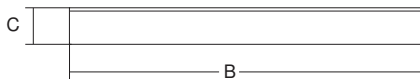
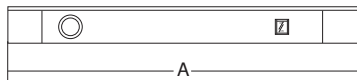

1. Facile pulizia
Easy cleaning

	Potenza Power Spannung Puissance	Alimentazione Power source Betriebsspannung Alimentation	Temperatura Temperature Temperatur Temperature	A	B	C	Peso netto Net weight Nettogewicht Poids net	Dimensioni imballo Shipping Verpack-abmessungen Dim. emballage	Peso lordo Gross weight Bruttogewicht Poids brut
	watt		°C	mm	mm	mm	Kg	mm	kg
Piastra Scaldapizza Inox	430	230V 50/60 Hz F+N	0÷60	500	500	90	13,4	550x550x150	15
Piastra Scaldapizza Vetro Temperato	430	230V 50/60 Hz F+N	0÷60	500	500	90	13,4	550x550x150	15

Potencia
Potência
Мощность

Alimentación
Alimentação
Электропитание
電源

Temperatura
Temperatura
Temperatur
温度

A B C

Peso neto
Peso líquido
Без тары
淨重

Dimensiones embalaje
Dimensões embalagem
Размеры упаковки
包裝尺寸

Peso bruto
Peso bruto
Вес брутто
毛重



PIASTRA SCALDAPIZZA VETRO TEMPERATO



VETRINETTE D. 38-42



vetrinette pizza brioches pizza and pastry display cabinets

- Vetrinetta per l'esposizione di pizze, brioches, torte, sfoglie e stuzzichini vari, che mantiene costante la temperatura e conserva a lungo il sapore e la morbidezza dei cibi.
- Costruita interamente in acciaio AISI 403 con vetri sui quattro lati.
- Porta con chiusura soft calamitata.
- Termostato di regolazione temperatura.
- Cassetto acqua per l'umidificazione dei prodotti.
- Ripiani girevoli che favoriscono una omogenea circolazione del calore e una migliore visione dei prodotti.

- *Display unit suitable to keep warm and fragrant for many hours pizza, pastries, savoury pies and many other snacks.*
- *Made from stainless steel AISI 403 and glass sides.*
- *Door with magnetic closure.*
- *Temperature adjustable by means of a thermostat.*
- *Small water basin for humidification of the product.*
- *Swivelling racks help a uniform heat diffusion and a better product view.*

VETRINETTA D.42

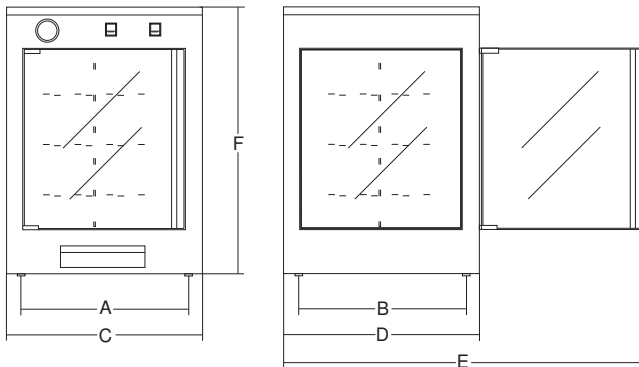

	Potenza Power Spannung Puissance	Alimentazione Power source Betriebsspannung Alimentation	Temperatura Temperature Temperatur Température	A	B	C	D	E	F	Peso netto Net weight Nettogewicht Poids net	Dimensioni imballo Shipping Verpack-abmessungen Dim. emballage	Peso lordo Gross weight Bruttogewicht Poids brut
	watt		°C	mm	mm	mm	mm	mm	mm	Kg	mm	kg
Vetrinetta D. 38	700	230V 50/60 Hz F+N	0 ÷ 90	390	360	465	430	820	590	23	600x600x800	30
Vetrinetta D. 42	700	230V 50/60 Hz F+N	0 ÷ 90	430	400	505	470	960	590	25	600x600x800	32

Potencia
Potência
Мощность
功率

Alimentación
Alimentação
Электропитание
電源

Temperatura
Temperatura
Temperatur
温度

A B C D E F

Peso netto
Peso líquido
Вес нетто
淨重

Dimensiones embalaje
Dimensões embalagem
Размеры упаковки
包裝尺寸

Peso bruto
Peso bruto
Вес брутто
毛重



VETRINETTA D. 38



FORNO PIZZA

pizza oven

- Forma robusta e compatta, studiata appositamente per sovrapporre altri forni pizza o la vetrinetta per l'esposizione.
- Realizzato totalmente in acciaio inox AISI 304.
- Resistenze corazzate in acciaio.
- Griglia di cottura in acciaio cromato.
- Pannello di chiusura bocca di carico.
- Pannelli isolanti a norme per un ottimo isolamento su tutte le superfici del forno.
- Temperatura di lavoro pre-impostata.
- Timer per la regolazione del tempo di cottura.
- Manopola ad elevata resistenza termica.
- Spia luminosa per la segnalazione presenza rete.



- *Compact and sturdy structure, designed to hold up other ovens or one Vetrinetta pizza displayer.*
- *Made from AISI 304 stainless steel.*
- *Shock-proof stainless steel heating elements.*
- *Galvanized steel grill.*
- *CE approved lining for thermal protection.*
- *Adjustable working temperature.*
- *Timer.*
- *Heat resistant knob.*
- *Pilot light.*

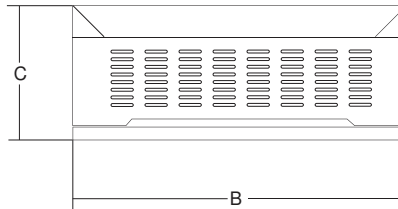
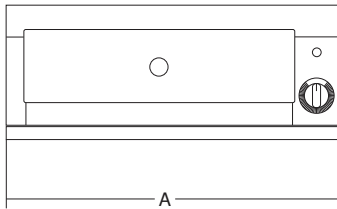

1. Impilabile con la Vetrinetta D. 38
Stacking with Vetrinetta D. 38

	Potenza Power Spannung Puissance	Alimentazione Power source Betriebsspannung Alimentation	Temperatura Temperature Temperatur Température	Dimensioni interne Internal dimensions Innenmaße Dimensions intérieures	A	B	C	Peso netto Net weight Nettogewicht Poids net	Dimensioni imballo Shipping Verpack- abmessungen Dim. emballage	Peso lordo Gross weight Bruttogewicht Poids brut
	watt		°C	mm	mm	mm	mm	Kg	mm	kg
Forno Pizza	1000+750	230V 50/60 Hz F+N	0 ÷ 330	360x430 h. 70	465	430	170	12	520x580x240	13,5
	Potencia Potência Мощность 功率	Alimentación Alimentação Электропитание 電源	Temperatura Temperatura Температура 温度	Dimensiones internas Dimensões internas Внутренние размеры 内部尺寸	A	B	C	Peso netto Peso líquido Вес нетто 淨重	Dimensiones embalaje Dimensões embalagem Размеры упаковки 包裝尺寸	Peso bruto Peso bruto Вес брутто 毛重





STROMBOLI

forni pizza pizza ovens

- Struttura in acciaio inox
- Piano di cottura in pietra refrattaria
- Resistenze corazzate
- Sfiato per i vapori di cottura
- Capacità per piano:
2 pizze Ø ≤ mm 225

- *Stainless steel construction*
- *Refractory brick deck*
- *Shock-proof heating elements*
- *Air-hole*
- *Capacity to 1 level:*
2 pizzas Ø ≤ mm 225



STROMBOLI 2

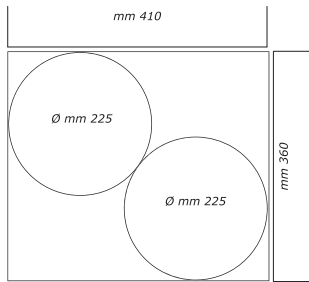

1. Piano di cottura in pietra refrattaria
Stone baking deck



2. Comandi Stromboli
Stromboli Controls

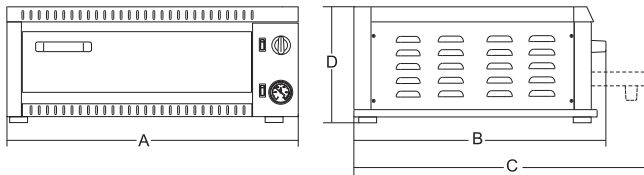

	Potenza Power Spannung Puissance	Alimentazione Power source Betriebsspannung Alimentation	Timer Timer Schaltuhr Minuterie	Temperatura Temperature Temperatur Température	Dimensioni interne internal dimensions Innenmaße Dimensions intérieures	A	B	C	D	Peso netto Net weight Nettogewicht Poids net	Dimensioni imballo Shipping Verpack abmessungen Dim. emballage	Peso lordo Gross weight Bruttogewicht Poids brut
	watt		min.	°C	mm	mm	mm	mm	mm	Kg	mm	kg
Stromboli	1600	230V 1N 50Hz	30	50÷350	410 x 360 h.80	580	490	550	245	25	660x540x320	27
Stromboli 2	3200	230V 1N 50Hz	30	50÷350	410 x 360 h.80	580	490	550	420	37	660x540x485	40
	Potencia Potência Мощность	Alimentación Alimentação 电源	Temporizador Timer Таймер 定时器	Temperatura Temperature Температура 温度	Dimensiones internas Dimensões internas Внутренние размеры 内部尺寸	A	B	C	D	Peso neto Peso líquido Вес нетто 净重	Dimensiones embalaje Dimensões embalagem Размеры упаковки 包装尺寸	Peso bruto Peso bruto Вес брутто 毛重



STROMBOLI



VULCANO

forni pizza
pizza ovens



VULCANO 2C

- Struttura in acciaio inox
- Piani di cottura in pietra refrattaria
- Resistenze corazzate
- Sfiato per i vapori di cottura
- Isolamento in fibra di ceramica
- 2 camere di cottura indipendenti isolate termicamente
- 2 termostati per ogni camera che regolano la zona inferiore e superiore.

- *Stainless steel construction*
- *Refractory brick decks*
- *Shock-proof heating elements*
- *Air-hole*
- *Ceramic fibre lining*
- *2 separate backing chambers thermal insulated*
- *2 thermostats for each chamber which select the lower and upper zone*



1. Piano di cottura in pietra refrattaria
Refractory brick deck

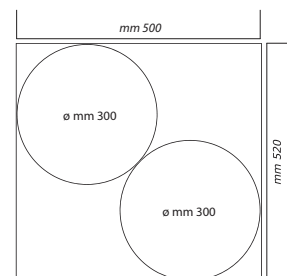
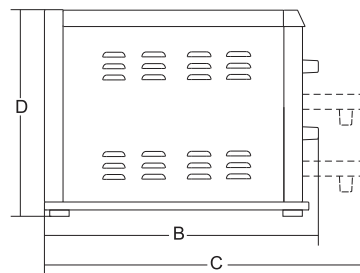
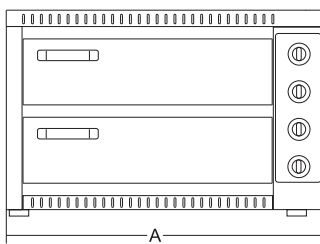

	Potenza Power Spannung Puissance	Alimentazione Power source Betriebsspannung Alimentation	Temperatura Temperature Temperatur Température	Dimensioni interne Internal dimensions Innenmaße Dimensions intérieures	A	B	C	D	Peso netto Net weight Nettogewicht Poids net	Dimensioni imballo Shipping Verpack. abmessungen Dim. emballage	Peso lordo Gross weight Bruttogewicht Poids brut
	watt		°C	mm	mm	mm	mm	mm	Kg	mm	kg
Vulcano 2C	6400	230-400V / 50Hz	50 ÷ 350	500 x 520 h.115	745	695	780	490	84	890x800x650	94
	Potencia Potência Мощность 功率	Alimentación Alimentação Электропитание 電源	Temperatura Temperatura Температура 温度	Dimensiones internas Dimensões internas Внутренние размеры 内部尺寸	A	B	C	D	Peso netto Peso líquido Вес нетто 淨重	Dimensiones embalaje Dimensões embalagem Размеры упаковки 包裝尺寸	Peso bruto Peso bruto Вес брутто 毛重



VESUVIO

forni pizza
pizza ovens



YouTube



1. Cappa aspirante opzionale
Fume hood optional

2. Cavalletto in alluminio con porta cassette pizza opzionale
Aluminium stand with pizza trays holder optional

- Struttura esterna in acciaio inox.
- Porta in acciaio inox con finestra a doppio vetro.
- Termometro per la visualizzazione della temperatura camera.
- Termostato di controllo temperatura in camera.
- 2 termostati per controllo separato delle resistenze inferiori e superiori.
- Doppia illuminazione interna.
- Piano in pietra refrattaria.
- Camino per il convogliamento di fumi e vapori.
- Cappa aspirante (230V/50Hz - watt 100) opzionale.
- I Vesuvio 85x70, 105x70 e 105x105 possono contenere 2 teglie da cm 60x40.
- S/steel construction.
- Stainless steel door with double glass window.
- It is possible to check the temperature inside the chamber by means of a thermometer.
- Temperature inside the chamber is controlled by a general thermostat.
- Heating of the upper and lower elements is adjustable by means of 2 separate symostats.
- Double interior lighting.
- Refractory brick deck.
- Fumes and vapour chimney.
- Fume hood (230V/50Hz) optional.
- Fits 2x 60x40 cm trays for Vesuvio 85x70, 105x70 and 105x105.



3. Piano di cottura in pietra refrattaria
Stone baking deck



4. Cavalletto alluminio standard opzionale
Optional standard aluminium table base



5. Cavalletto alluminio con porta cassetta opzionale
Optional aluminium stand with pizza trays holder

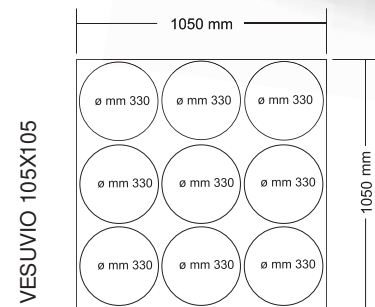
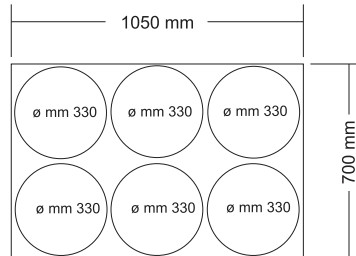
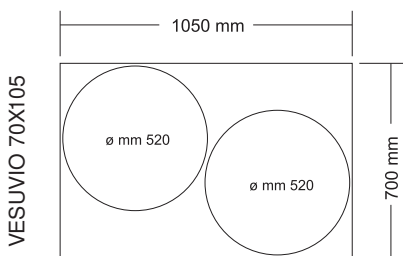
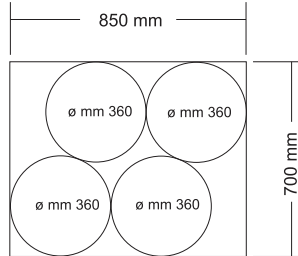
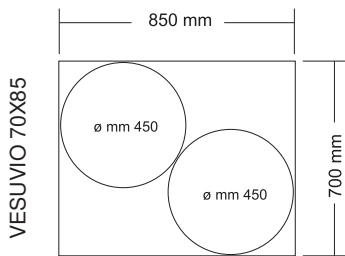
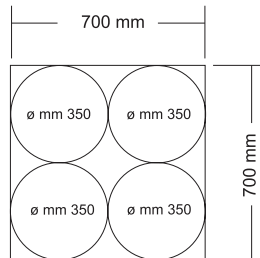
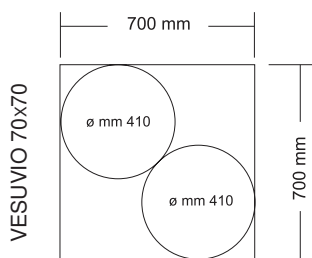

VESUVIO 70X70 EL



VESUVIO 105X70 EL

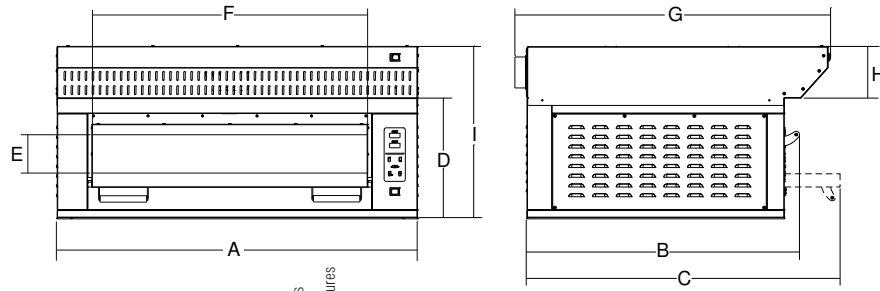

	Potenza Power Spannung Puissance	Alimentazione Power source Betriebsspannung Alimentation	Temperatura Temperature Temperatur Température	Dimensioni interne Internal dimensions Innenmaße Dimensions intérieures	A	B	C	D	E	F	G	H	I	Peso netto Net weight Nettogewicht Poids net	Dimensioni imballo Shipping Verpack-abmessungen Dim. emballage	Peso lordo Gross weight Bruttogewicht Poids brut
	watt		°C	mm	mm	mm	mm	mm	mm	mm	mm	mm	mm	Kg	mm	kg
Vesuvio 70x70	5850	400V + N 50/60 Hz 3F	0 ÷ 350	700x700 h.149	995	900	1015	395	119	700	1038	171	566	80	1050x950x700	100
Vesuvio 85x70	7200	400V + N 50/60 Hz 3F	0 ÷ 350	850x700 h.149	1190	905	1015	395	119	850	1038	171	566	83	1200x1000x700	103
Vesuvio 85x70 2C	7200 (x2)	400V + N 50/60 Hz 3F	0 ÷ 350	850x700 h.149 (x2)	1190	905	1015	720	119	850	1038	171	891	166	-	-
Vesuvio 105x70	9000	400V + N 50/60 Hz 3F	0 ÷ 350	1050x700 h.149	1395	920	1030	365	119	1050	1112	221	586	115	1200x1000x700	130
Vesuvio 105x70 2C	9000 (x2)	400V + N 50/60 Hz 3F	0 ÷ 350	1050x700 h.149 (x2)	1395	920	1030	660	119	1050	1112	221	881	230	-	-
Vesuvio 105x105	13500	400V + N 50/60 Hz 3F	0 ÷ 350	1050x1050 h.149	1395	1280	1030	365	119	1050	1445	260	625	147	-	-

	Potencia Potência Мощность 功率	Alimentación Alimentação Электропитание 電源	Temperatura Temperatura Температура 溫度	Dimensiones internas Dimensões internas Внутренние размеры 内部尺寸	A	B	C	D	E	F	G	H	I	Peso neto Peso líquido Бес нетто 淨重	Dimensiones embalaje Dimensões embalagem Размеры упаковки 包裝尺寸	Peso bruto Peso bruto Бес брутто 毛重
--	--	---	---	--	---	---	---	---	---	---	---	---	---	--	---	--

Cavalletto alluminio standard
Standard aluminium table base

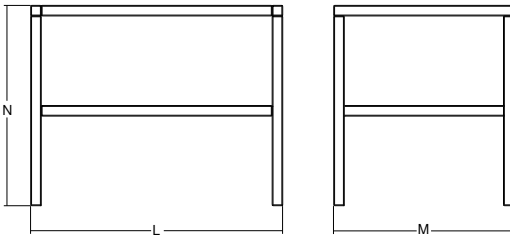

	L	M	N	n.
	mm	mm	mm	
Vesuvio 70x70	995	855	950	
	995	855	1150	
Vesuvio 85x70	1195	855	950	
	1195	855	1150	
Vesuvio 85x70 2C	1195	855	950	
	1195	855	1150	
Vesuvio 105x70	1395	855	950	
	1395	855	1150	
Vesuvio 105x70 2C	1395	855	950	
	1395	855	1150	
Vesuvio 105x105	1395	1242	950	
	1395	1242	1150	

L M N

Cavalletto alluminio con porta cassetta pizza
Aluminium table base with pizza trays holder

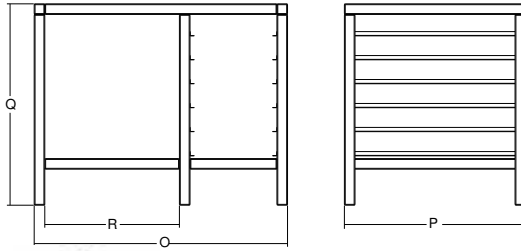

	O	P	Q	R	n.	n.
	mm	mm	mm	mm		
Vesuvio 70x70	995	855	950	435	6	
	995	855	1150	435	7	
Vesuvio 85x70	1195	855	950	635	6	
	1195	855	1150	635	7	
Vesuvio 85x70 2C	1195	855	950	635	6	
	1195	855	1150	635	7	
Vesuvio 105x70	1395	855	950	635	6+6	
	1395	855	1150	635	7+7	
Vesuvio 105x70 2C	1395	855	950	635	6+6	
	1395	855	1150	635	7+7	
Vesuvio 105x105	1395	1242	950	635	6+6	
	1395	1242	1150	635	7+7	

O P Q R

Cassette cm 60x40
Trays cm 60x40
Tablets 60x40 cm
Cassées cm 60x40

Caixias 60x40 cm
Bandejas 60x40 cm
Vassos 60x40 cm
托盤 60x40

PIZZA



accessori per la pizza pizza accessories

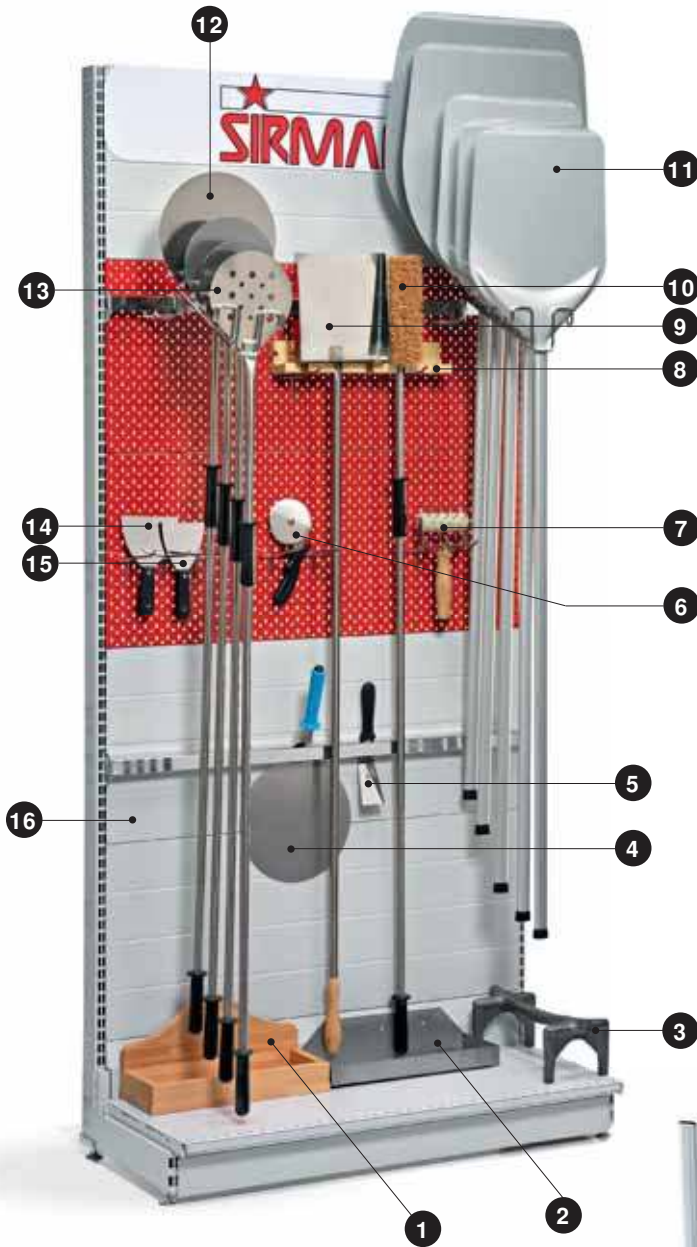

- Aluminium shovels, light and handy ⁽¹¹⁾:
cm 30x33 h.170
cm 33x33 h.170
cm 36x36 h.170
cm 45x45 h.170
cm 50x50 h.170
- Stainless steel little shovels with anti-burn anatomical hilt, available in two versions:
Normal ⁽¹²⁾:
cm ø 16 h.170
cm ø 18 h.170
cm ø 20 h.170
cm ø 26 h.170
Punched ⁽¹³⁾:
cm ø 16 h.170
cm ø 18 h.170
cm ø 20 h.170
- Dustpan ash collecting h.170 ⁽⁹⁾
- Natural fibre long-hoodled scrubbing-brush ⁽¹⁰⁾
- Wall support to hanger 3 little shovels and 2 shovels ⁽⁸⁾
- Wall support to hang little shovels
- Column support to hang shovels pizza ⁽¹⁶⁾
- Wall support to stand shovels ⁽¹⁷⁾
- Wooden case to stand shovels ⁽¹⁾
- Stainless steel case to stand shovels ⁽²⁾

- Pale in alluminio leggere e maneggevoli ⁽¹¹⁾:
cm 30x33 h.170
cm 33x33 h.170
cm 36x36 h.170
cm 45x45 h.170
cm 50x50 h.170
- Palini in acciaio inox con impugnatura anatomica antiscottamento, disponibili in due modelli:

Normali ⁽¹²⁾:

- cm ø 16 h.170
- cm ø 18 h.170
- cm ø 20 h.170
- cm ø 26 h.170

Forati ⁽¹³⁾:

- cm ø 16 h.170
- cm ø 18 h.170
- cm ø 20 h.170

- Paletta per raccolta cenere h.170 ⁽⁹⁾
- Spazzolone in fibra naturale ⁽¹⁰⁾
- Supporto a muro per appendere 3 palini e 2 pale ⁽⁸⁾
- Supporto a muro per appendere palini
- Supporto a colonna per appendere le pale ⁽¹⁶⁾
- Supporto a muro per appoggiare le pale ⁽¹⁷⁾
- Cassetta in legno per appoggiare le pale ⁽¹⁾
- Cassetta in acciaio per appoggiare le pale ⁽²⁾
- Alare per appoggio legna ⁽³⁾
- Bucasfoglia in lega di alluminio ⁽⁷⁾
- Cacciapizza in acciaio ⁽⁴⁾
- Rotella taglia pizza d. 90 mm ⁽⁶⁾
- Spatole in acciaio inox cm 10 ⁽¹⁵⁾
- Spatole in acciaio inox cm 12 ⁽¹⁴⁾
- Paletta servi pizza cm 5x13 ⁽⁵⁾
- Tagliere in polietilene per pizza, ø cm 33
- Tagliere in polietilene per pizza, ø cm 40
- Tagliere in polietilene per pizza, ø cm 50
- Espositore accessori per la pizza ⁽¹⁶⁾



- Firedog for firewood ⁽³⁾
- Aluminium alloy puff-pierce ⁽⁷⁾
- "Cacciapizza" pizza server shovel ⁽⁴⁾
- Pizza cutter roller d. 90 mm ⁽⁶⁾
- Stainless steel spatula cm 10 ⁽¹⁵⁾
- Stainless steel spatula cm 12 ⁽¹⁴⁾
- "Paletta Servipizza" pizza server, stainless steel cm 5x13 ⁽⁵⁾
- Polyethylene cutting board ø cm 33
- Polyethylene cutting board ø cm 40
- Polyethylene cutting board ø cm 50
- Pizza accessories exhibitor ⁽¹⁶⁾



LINEA BAR | BAR LINE

Strumenti indispensabili per spremere, frullare, amalgamare, montare e preparare bevande adatte a soddisfare qualsiasi palato, le macchine da bar firmate Sirman sono tutte progettate e realizzate per garantire: la massima sicurezza nell'uso, pulizia e manutenzione; un'assoluta igiene grazie alla selezione di materiali adatti al contatto con gli alimenti e all'eliminazione degli spigoli nelle parti della macchina destinati al contatto col prodotto; una perfetta resa, robustezza e stabilità di tutti i componenti e, ancora, la più totale silenziosità e maneggevolezza. Caratterizzati da un design brillante ed innovativo, volto ad unire armonicamente estetica e funzionalità, gli strumenti proposti da Sirman sono adatti a soddisfare le più diverse esigenze dei professionisti del settore e, come tali, presenze indispensabili in ogni locale all'avanguardia.

Indispensable tools for squeezing, whisking, blending, whipping and preparing drinks to suit everybody's taste, Sirman drinks bar machines are all designed and manufactured to ensure the utmost safety in use, cleanliness and easy maintenance; absolute hygiene thanks to the selection of materials suitable for contact with foodstuffs and the elimination of any sharp edges in the parts of the machine that come into contact with the food products; great efficiency, sturdiness and stability of all the components and, also important, very low noise levels and easy handling.

Characterized by a bright and innovative design, designed to achieve a harmonious combination of good looks and practicality, these tools by Sirman are designed to satisfy a great variety of needs for professionals in this sector and as such, are an indispensable aid in every modern drinks bar.





SIRIO

frappè drink mixers



- Famiglia completa di macchine per il frappè caratterizzato da linee morbide e precise. Studiato per un utilizzo professionale e severo nel rispetto delle norme di sicurezza europee e nordamericane.
- Corpo macchina bianco o cromato, colonna in alluminio estruso e base in pressofusione per una ottima stabilità della macchina, il tutto privo di angoli e giunzioni per facilitare la pulizia.
- Disponibile nella versione da banco 1 o 2 bicchieri o a parete.
- Bicchiere da 550 cc in Tritan trasparente o a richiesta in acciaio inox.
- Bicchiere da 900 cc in acciaio inox su versione da 120 watt.
- Motore potente e ventilato per una maggiore durata.
- Versione con 3 fruste in alluminio e acciaio per la preparazione di frappè e sorbetti o con disco appositamente studiato per il caffè shakerato o per montare il prodotto in lavorazione.
- Microinterruttore di sicurezza sul bicchiere (opzionale per paesi extra UE).
- Variatore di velocità a richiesta.

- *A complete line of drink mixers with a soft design.*
- *Designed to commercial use, they meet all European and North-American safety requirements.*
- *White or chrome head, aluminium stem and die casting base for a perfect stability, no edges or seams for easier cleaning.*
- *Countertop (1 or 2 cups) or wall unit versions available.*
- *Transparent 550 cc Tritan cup or stainless steel cup on request.*
- *900 cc stainless steel cup on 120 W version.*
- *Powerful ventilated motor for a longer life.*
- *Spindle with three aluminium and s/steel agitators for preparing milkshakes and drinks, or with a special round agitator for frozen coffees or for creamier results.*
- *Safety microswitch on the cup support (optional for non UE countries).*
- *Speed control on request.*



SIRIO 120W 900 CC



SIRIO GRIGIO



SIRIO 2 VV



SIRIO 2



SIRIO CAFFÈ



1. Particolare fruste, Sirio 120 watt - 900cc
Sirio 120 - 900 watts agitators



2. Opzionale: Anello portabicchieri usa e getta
Optional: ring for paper cups

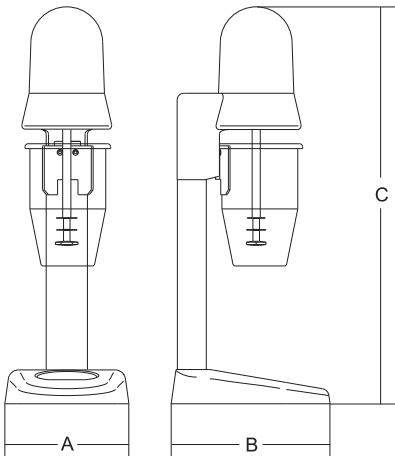

	Potenza Power Spannung Puissance	Alimentazione Power source Betriebsspannung Alimentation	Motore Motor Moteur	Capacità bicchiere Jug capacity Kapazität Capacité verre	A	B	C	Peso netto Net weight Nettogewicht Poids net	Dimensioni imballo Shipping Verpack. abmessungen Dim. emballage	Peso lordo Gross weight Bruttogewicht Poids brut
	watt/Hp		r.p.m.	lt	mm	mm	mm	Kg	mm	kg
Sirio 1	100/0,14	230V 50/60 Hz F+N	14000	0,55	150	195	485	2,5	210x250x520	3,5
Sirio 2	100+100/0,14+0,14	230V 50/60 Hz F+N	14000	0,55x2	300	195	485	5	370x260x530	6,5
Sirio 1P	100/0,14	230V 50/60 Hz F+N	14000	0,55	110	150	360	2	190x240x510	4
Sirio 1 VV	100/0,14	230V 50/60 Hz F+N	4000÷14000	0,55	150	195	485	2,5	210x250x520	3,5
Sirio 2 VV	100+100/0,14+0,14	230V 50/60 Hz F+N	4000÷14000	0,55x2	300	195	485	5	370x260x530	6,5
Sirio Grigio	100/0,14	230V 50/60 Hz F+N	14000	0,55	150	195	485	2,5	210x250x520	3,5
Sirio 1 - 120W cc 900	120/0,16	230V 50/60 Hz F+N	14000	0,9	150	195	530	3	210x250x560	4,5
Sirio 1 VV - 120W cc 900	120/0,16	230V 50/60 Hz F+N	4000÷14000	0,9	150	195	530	3	210x250x560	4,5
Sirio 2 - 120W cc 900	120+120/0,16+0,16	230V 50/60 Hz F+N	14000	0,9x2	300	195	530	6	360x250x560	7
Sirio 2 VV - 120W cc 900	120+120/0,16+0,16	230V 50/60 Hz F+N	4000÷14000	0,9x2	300	195	530	6	360x250x560	7



SIRIO 1 / SIRIO 1 VV



SIRIO 1P VV



SIRIO 1P



DRAGONE

frullatori blenders

- Frullatore Dragone nato dalle specifiche esigenze del bar moderno, particolarmente adatto per preparare frullati e bevande di frutta e verdura.
- Corpo macchina bianco o cromato, privo di angoli e giunzioni per facilitare la pulizia.
- Motore ad elevata potenza con ventilazione forzata.
- Bicchiere da 1,5 litri in Tritan trasparente infrangibile, lavabile in lavastoviglie, graduato in litri e galloni UK e USA.
- Coperchio bicchiere in gomma a perfetta tenuta con tappo e bicchierino graduato per l'aggiunta degli ingredienti durante la lavorazione.
- Sistema di trasmissione con denti contrapposti in metallo e gomma per una elevata trasmissione della potenza e bassa rumorosità.
- Coltello a 4 razze ricavato da un unico stampaggio, in acciaio inox da coltelleria facilmente smontabile.
- Microinterruttore di sicurezza sul coperchio bicchiere.
- Variatore di velocità a richiesta.

- *Designed to meet the specific needs of the modern bar, it is particularly suitable for preparing smoothies, fruit and vegetables drinks.*
- *White or chrome body, no edges or seams for easy cleaning.*
- *Powerful ventilated motor.*
- *Transparent, unbreakable 1,5 lt Tritan container is dishwasher safe and graduated with litres and UK/ USA gallons.*
- *Tight rubber lid with feed opening to add ingredients while the blender is working.*
- *Metal and rubber gears drive gives a high power transmission and quiet operation.*
- *4-blades stainless steel knife can be easily disassembled.*
- *Safety microswitch on the lid.*
- *Speed control on request.*



DRAGONE CROMATO



DRAGONE GRIGIO

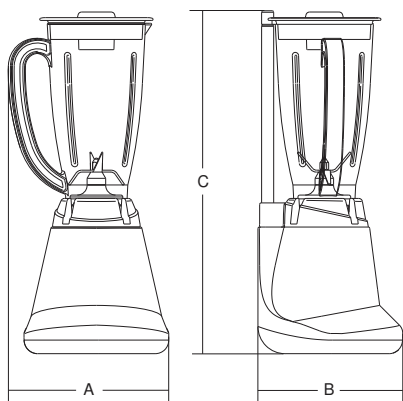

Potenza
Power
Spannung
Puissance



1. Dragone caffè
Dragone coffee



2. Micro su coperchio
Microswitch on cover



3. Opzionale: Variatore di velocità
Speed control optional

Alimentazione
Power source
Betriebsspannung
Alimentation

Motore
Motor
Motor
Moteur

Capacità bicchiere
Jug capacity
Kapazität
Capacité verre

A B C

Peso netto
Net weight
Nettogewicht
Poids net

Dimensioni imballo
Shipping
Verpack. abmessungen
Dim. emballage

Peso lordo
Gross weight
Bruttogewicht
Poids brut

	watt/Hp	230V 50/60 Hz F+N	r.p.m.	lt	mm	mm	mm	Kg	mm	kg
Dragone	450/0.60	230V 50/60 Hz F+N	16000	1,5	213	200	416	3	310x300x530	4
Dragone VV	450/0.60	230V 50/60 Hz F+N	11000/16000	1,5	213	200	416	3	310x300x530	4

Potencia
Potência
Мощность
功率

Alimentação
Alimentação
Электропитание
电源

Motor
Motor
Двигатель
电机

Capacidad vaso
Capacidade copo
Объем стакана
容量
容杯

A B C

Peso neto
Peso líquido
Вес нетто
净重

Dimensiones embalaje
Dimensões embalagem
Размеры упаковки
包装尺寸

Peso bruto
Peso bruto
Вес брутто
毛重



SATURNO

frullatori blenders



SATURNO

- Frullatore Saturno nato dalle specifiche esigenze del bar moderno, particolarmente adatto per preparare frullati e bevande di frutta e verdura.
- Corpo macchina in acciaio inox, privo di angoli e giunzioni per facilitare la pulizia.
- Motore ad elevata potenza con ventilazione forzata.
- Bicchiere da 1,5 litri in Tritan trasparente infrangibile, lavabile in lavastoviglie, graduato in litri e galloni UK e USA.
- Coperchio bicchiere in gomma a perfetta tenuta con tappo e bicchierino graduato per l'aggiunta degli ingredienti durante la lavorazione.
- Sistema di trasmissione in gomma vulcanizzata a denti contrapposti per una elevata trasmissione della potenza e bassa rumorosità.
- Coltello a 4 razze ricavato da un unico stampaggio, in acciaio inox da coltelleria facilmente smontabile.
- Microinterruttore di sicurezza sul coperchio bicchiere.
- Variatore di velocità a richiesta.

- *Designed to meet the specific needs of the modern bar, it is particularly suitable for preparing smoothies, fruit and vegetables drinks.*
- *Seamless stainless steel body for easy cleaning.*
- *Powerful ventilated motor.*
- *Transparent, unbreakable 1,5 lt Tritan container is dishwasher safe and graduated with litres and UK/ USA gallons.*
- *Tight rubber lid with feed opening to add ingredients while the blender is working.*
- *Vulcanized rubber gears drive gives a high power transmission and quiet operation.*
- *4-blades stainless steel knife can be easily disassembled.*
- *Safety microswitch on the lid.*
- *Speed control on request.*

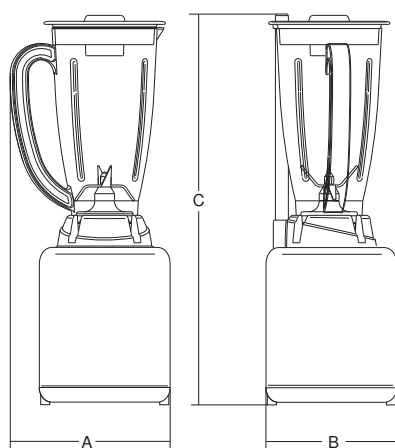

1. Saturno caffè
Saturno coffee



2. Mozzo smontabile inox
Removable s/s knives assembly



3. Opzionale: Variatore di velocità
Speed control optional

	Potenza Power Spaaning Puissance	Alimentazione Power source Betriebsspannung Alimentation	Motore Motor Motor Moteur	Capacità bicchiere Jug capacity Kapazität Capacité verre	A	B	C	Peso netto Net weight Nettogewicht Poids net	Dimensioni imballo Shipping Verpack. abmessungen Dim. emballage	Peso lordo Gross weight Bruttogewicht Poids brut
	watt/Hp		r.p.m.	lt	mm	mm	mm	Kg	mm	kg
Saturno	450/0,60	230V 50/60 Hz F+N	16000	1,5	213	200	416	3,5	310x300x530	4,5
Saturno VV	450/0,60	230V 50/60 Hz F+N	11000/16000	1,5	213	200	416	3,5	310x300x530	4,5

Potencia
Potência
Мощность
功率

Alimentación
Alimentação
Электропитание
電源

Motor
Motor
Двигатель
电机

Capacidad vaso
Capacidade copo
Объем стакана
容量

A B C

Peso líquido
Bec netto
净重

Dimensiones embalaje
Dimensões embalagem
Размеры упаковки
包装尺寸

Peso bruto
Peso bruto
Брутто
毛重



ORIONE

frullatori blenders



Frullatore professionale nato dalle specifiche esigenze del bar, ristorante, mensa, ecc.

- Corpo macchina in alluminio estruso e fianchi in ABS da 1 o 2 bicchieri per la versione alluminio e corpo macchina in acciaio inox per la versione inox.
- Potente motore con ventilazione forzata, per un utilizzo prolungato e una maggiore durata.
- Affidabile sistema di trasmissione a bassa rumorosità.
- Microinterruttore magnetico di sicurezza sul coperchio bicchiere senza posizione obbligatoria.
- Comandi on-off-pulse con variatore di velocità di serie.

Bicchiere quadro

Il bicchiere quadro è stato sviluppato per lavorare al meglio con grandi quantità di ghiaccio anche a secco.

Stesse caratteristiche costruttive del bicchiere tondo più:

- Pratico e funzionale: si può versare il prodotto su 3 diverse direzioni
- Ideale per la preparazione di frozen drink o smoothie con sciroppi e concentrati.
- trascinatore motore multipunto in acciaio inox.

Bicchiere tondo

- Capacità 2 litri realizzato in Tritan trasparente infrangibile, lavabile in lavastoviglie, graduato in litri, galloni UK e USA o bicchiere in acciaio inox da 2 litri e 5 litri per la versione Five.
- Coperchio bicchiere in gomma o in poliestere per l'Orione Five, entrambi a perfetta tenuta con tappo e bicchierino.
- Supporto coltelli in acciaio inox completamente e facilmente smontabile dal corpo bicchiere.
- Coltello a 4 razze ricavato da un unico stampaggio in acciaio temperato da coltelleria.



ORIONE Q VV

Professional mixer designed to cater to the specific requirements of bars, restaurants, cafeterias, etc.

- *Machine structure in extruded aluminium and sides in ABS with 1 or 2 glasses for the aluminium version and machine structure in stainless steel for the stainless steel version.*
- *Powerful motor with forced ventilation, for prolonged use and enhanced durability.*
- *Reliable low-noise transmission system.*
- *Magnetic safety micro-switch on glass lid without forced position.*
- *On-off pulse controls with speed variator (standard feature).*

Square glass

The square glass has been developed to ideally work with large quantities of ice, even dry.

Same features of the round glass version, plus:

- *Handy and practical: you can pour the product in 3 different directions.*
- *Perfect to prepare frozen drinks or smoothies with syrups and concentrates.*
- *Multi-point motor puller in stainless steel.*

Round glass

- *2 litre capacity, built out of transparent, indestructible Tritan, can be washed in dishwasher, graduated in litres, UK and U.S. gallons, or 2 litre and 5 litre glass in stainless steel for the Five version.*
- *Glass lid in rubber or polyester for Orione Five, both with airtight seal with cap and glass.*
- *Knife support in stainless steel that can be fully and easily disassembled from the glass body.*
- *Knife with 4 spokes obtained from a single mould in tempered cutlery steel.*



ORIONE T VV



ORIONE 2 Q VV



ORIONE 2 T VV



1. Orione VV



2. Orione Timer VV



3. Orione Plus VV:
9 programmi pre-impostati
9 pre-set programs



6. Bicchieri quadri impilabili
Stackable square glass



4. Trascinatori inox per Orione Q
Stainless steel gears on Orione Q



5. Base frappè
Milkshake application



7. Campana opzionale
Optional sound enclosure



8. Bicchiere inox opzionale
Optional s/steel glass

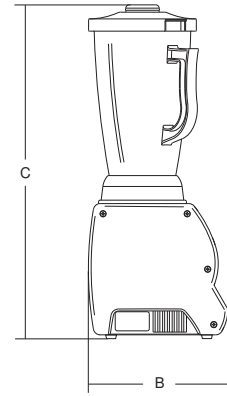
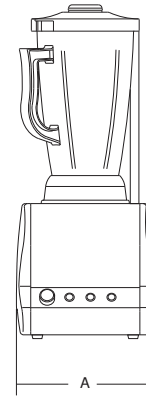

	Potenza Power Spannung Puissance	Alimentazione Power source Betriebsspannung Alimentation	Motore Motor Motor Moteur	Capacità bicchiere Jug capacity Kapazität Capacité verre	A	B	C	Peso netto Net weight Nettogewicht Poids net	Dimensioni imballo Shipping Verpack. abmessungen Dim. emballage	Peso lordo Gross weight Bruttogewicht Poids brut
	watt/Hp		r.p.m.	lt	mm	mm	mm	Kg	mm	kg
Orione Q / VV	750/1	230V 50/60 Hz F+N	8000/16000	2	208	210	490	5	310x300x530	7
Orione T / VV	750/1	230V 50/60 Hz F+N	8000/16000	2	208	210	490	5	310x300x530	7
Orione 2 Q / VV	750+750 / 1+1	230V 50/60 Hz F+N	8000/16000	2+2	380	210	490	10	480x300x530	12
Orione 2 T / VV	750+750 / 1+1	230V 50/60 Hz F+N	8000/16000	2+2	380	210	490	10	480x300x530	12
Orione Five	750 / 1	230V 50/60 Hz F+N	8000/16000	5	245	260	540	7	340x330x640	9



ORIONE FIVE



9. Bicchiere smontato per la pulizia
Disassembled container for cleaning

Potencia
Potência
Мощность

Alimentación
Alimentação
Электропитание
電源

Motor
Motor
Двигатель
电机

Capacidad vaso
Capacidade copo
Объем стакана
容量

A

B

C

Peso neto
Peso líquido
Вес нетто
净重

Dimensiones embalaje
Dimensões embalagem
Размеры упаковки
包裝尺寸

Peso bruto
Peso bruto
Вес брутто
毛重



BARMASTER

frullatori blenders

Caratteristiche costruttive e di performance come ORIONE VV ma con possibilità di usufruire:

- 20 programmi pre-impostati di cui 4 associabili ai 4 pulsanti su tastiera, gli altri 16 richiamabili attraverso il menu, tutti riprogrammabili.
- 9 programmi impostati attraverso autoapprendimento.
- Display per la visualizzazione dei programmi e del funzionamento.
- Campana trasparente silenziante disponibile su richiesta.

Bicchiere quadro

Il bicchiere quadro è stato sviluppato per lavorare al meglio con grandi quantità di ghiaccio anche a secco.

Stesse caratteristiche costruttive del bicchiere tondo più:

- Pratico e funzionale: si può versare il prodotto su 3 diverse direzioni.
- Ideale per la preparazione di frozen drink o smoothie con sciroppi e concentrati.
- Trascinatore motore multipunto in acciaio inox.

Bicchiere tondo

- Capacità 2 litri realizzato in Tritan trasparente infrangibile, graduato in litri, galloni UK e USA.
- Coperchio bicchiere in gomma a perfetta tenuta con tappo e bicchierino.
- Supporto coltelli in acciaio inox completamente e facilmente smontabile dal corpo bicchiere. Coltello a 4 razze ricavato da un unico stampaggio in acciaio temperato da coltelleria.

Constructional and performance features like the ORIONE VV, but with the added option of using:

- 20 pre-set programs, of which 4 can be linked to 4 keys on the keypad and the other 16 can be recalled through the menu (all can be reprogrammed).
- 9 programs set in self-learning mode.
- Display to view the programs and machine operation.
- Transparent silencing bell available on request.

Square glass

The square glass has been developed to ideally work with large quantities of ice, even dry.

Same features of the round glass version, plus:

- Handy and practical: you can pour the product in 3 different directions.
- Perfect to prepare frozen drinks or smoothies with syrups and concentrates.
- Multi-point motor puller in stainless steel.

Round glass

- 2 litre capacity, built out of transparent, indestructible Tritan, graduated in litres, UK and U.S. gallons.
- Glass lid in rubber with airtight seal with cap and glass
- Knife support in stainless steel that can be fully and easily disassembled from the glass body. Knife with 4 spokes obtained from a single mould in tempered cutlery steel.



YouTube



BARMASTER Q
1. con campana silenziante
with sound enclosure

BARMASTER Q
2. senza campana silenziante
without sound enclosure



BARMASTER T
3. con campana silenziante
with sound enclosure

BARMASTER T
4. senza campana silenziante
without sound enclosure



5. Trascinatori inox per Barmaster Q
Stainless steel gears on Barmaster Q



6. Bicchieri quadri impilabili
Stackable square glass



7. Bicchiere e campana facilmente smontabili per la pulizia
Disassembled container and sound enclosure for cleaning

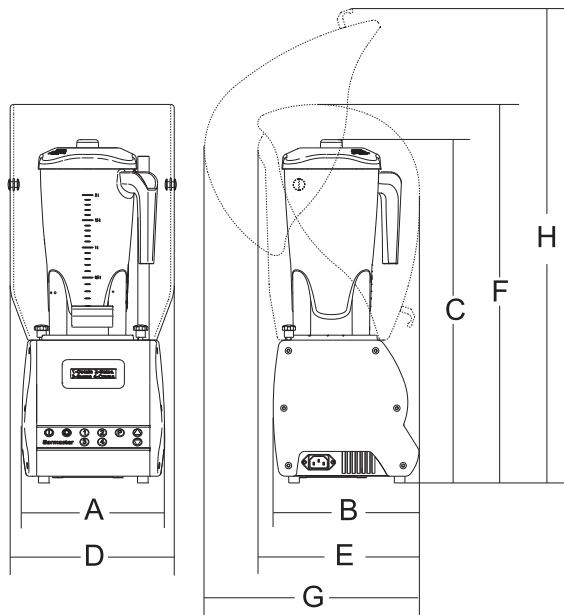

	Potenza Power Spannung Puissance	Alimentazione Power source Betriebsspannung Alimentation	Motore Motor Motor Moteur	Capacità bicchiere Jug capacity Kapazität Capacité verre	A	B	C	D	E	F	G	H	Peso netto Net weight Nettogewicht Poids net	Dimensioni imballo Shipping Verpack. abmessungen Dim. emballage	Peso lordo Gross weight Bruttogewicht Poids brut
	watt/HP	230V 50/60 Hz F+N	r.p.m.	lt	mm	mm	mm	mm	mm	mm	mm	mm	Kg	mm	kg
Barmaster Q	750/1	230V 50/60 Hz F+N	8000÷16000	2	208	210	490	240	230	535	315	670	5	305x305x525	7
Barmaster T	750/1	230V 50/60 Hz F+N	8000÷16000	2	208	210	490	240	230	535	315	670	5	305x305x525	7
Campana Sound enclosure													1	305x305x525	2
	Potencia Potência Мощность	Alimentación Alimentação Электропитание 電源	Motor Motor Двигатель 电机	Capacidad vaso Capacidade copo Объем стакана 容量	A	B	C	D	E	F	G	H	Peso neto Peso líquido Bec netto 净重	Dimensiones embalaje Dimensões embalagem Размеры упаковки 包装尺寸	Peso bruto Peso bruto Брутто вес 毛重



APO LLO

spremiagrumi / citrus juicers



- Spremiagrumi professionale dal design piacevolmente arrotondato adatto per un utilizzo intenso in tutti i bar che necessitano di una lavorazione semplice ed intuitiva.
 - Corpo macchina bianco o cromato, privo di angoli e giunzioni per facilitare la pulizia.
 - Vasca di lavorazione in acciaio inox rimovibile per la pulizia ed il lavaggio anche in lavastoviglie; a richiesta vasca in ABS dalle generose dimensioni e una maggiore economicità della macchina.
 - Setaccio mobile con due dimensioni di pigna per adattarsi a tutti i tipi di agrume.
 - A richiesta versione con leva in alluminio e acciaio inox per lavorare senza sporcarsi le mani.
 - Microinterruttore brevettato sulla pigna che permette di accendere direttamente la macchina premendo l'agrumo. Su richiesta senza microinterruttore per una maggiore economicità della macchina.
 - Variatore di velocità a richiesta.
-
- Commercial easy to use citrus juicer with round design.
 - White or chrome body, no edges or seams for easy cleaning
 - Stainless steel bowl is removable for cleaning and is dishwasher safe, ABS bowl available on request
 - Removable sieve with reamer in two sizes to squeeze any kind of citrus.
 - Aluminium stainless steel lever to avoid any food contact is available on request.
 - Patented safety microswitch on the cone allows to activate the juicer when the product is pushed down. The juicer is available without microswitch as well.
 - Speed control on request.



APOLLO CROMATO VV



1. Opzionale: Coperchio
Optional: Lid

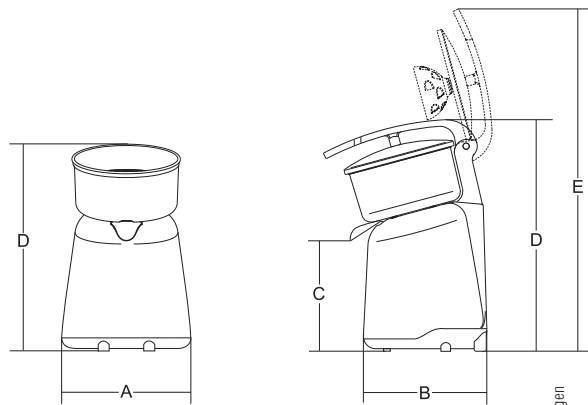

	Potenza Power Spannung Puissance	Alimentazione Power supply Betriebsspannung Alimentation	Giri/min. Revolutions/min. Kreislau/min. Tours /min.	A	B	C	D	E	Peso netto Net weight Netto Gewicht Poids net	Dimensioni imballo Shipping Verpack-abmessungen Dim. emballage	Peso lordo Gross weight Brutogewicht Poids brut
	Watt/Hp		r.p.m.	mm	mm	mm	mm	mm	Kg	mm	kg
Apollo ECO	150/0,20	230V 50/60 Hz F+N	320	210	210	155	310	-	2,5	270x340x370	3,5
Apollo	150/0,20	230V 50/60 Hz F+N	320	210	210	155	290	-	3	270x340x370	4
Apollo VV	150/0,20	230V 50/60 Hz F+N	280÷750	210	210	155	290	-	3	270x340x370	4
Apollo con leva	150/0,20	230V 50/60 Hz F+N	320	210	265	155	330	480	3,5	270x340x370	4,5
Apollo con leva VV	150/0,20	230V 50/60 Hz F+N	280÷750	210	265	155	330	480	3,5	270x340x370	4,5

	Potencia Potência Мощность 功率	Alimentación Alimentação Электропитание 電源	Vueltas / minuto Giros/min. Обороты/мин. 转速/分钟	A	B	C	D	E	Peso neto Peso líquido Вес нето 淨重	Dimensiones embalaje Dimensões embalagem Размеры упаковки 包裝尺寸	Peso bruto Peso unido Вес брутто 毛重
--	--	---	---	---	---	---	---	---	---	---	--



APOLLO ECO / APOLLO



APOLLO CON LEVA VV



2. Setaccio con 2 pigne
Sieve with 2 reamers

3. Pigna piccola
Reamer Small

4. Pigna grande
Reamer big



MERCURIO

spremiagrumi citrus juicers

- Imponente e prestante, adatto a grossi carichi di lavoro.
- Struttura in alluminio anodizzato.
- Vasca e leva in acciaio inox Aisi 304.
- Potente motore ventilato con riduzione ad ingranaggi.
- Setaccio mobile con due dimensioni di pigna per adattarsi a tutti i tipi di agrume.
- Microinterruttore su pigna di serie.
- Variatore di velocità opzionale.
- Pratico sottobicchiere salvagoccia.

- *Imposing, efficient, heavy-duty juicer.*
- *Anodized aluminium construction.*
- *AISI 304 stainless steel bowl and lever.*
- *Powerful ventilated motor with gear drive.*
- *Removable sieve with reamer in two sizes to squeeze any kind of citrus.*
- *Standard microswitch on the reamer.*
- *Optional speed control.*
- *Practical mat.*



MERCURIO CON LEVA

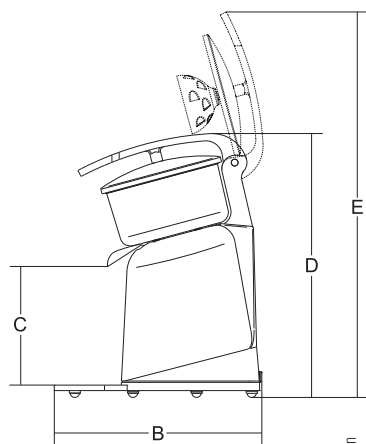
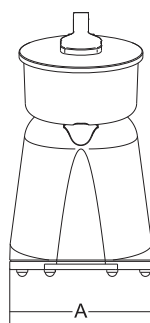

Potenza
Power
Spannung
Puissance

Alimentazione
Power source
Betriebsspannung
Alimentation

Giri/min.
Revolutions/min.
Kreislau/min.
Tours/min.

A

B

C

D

E

Peso netto
Net weight
Nettogewicht
Poids net

Dimensioni imballo
Shipping
Verpack. abmessungen
Dim. emballage

Peso lordo
Gross weight
Bruttogewicht
Poids brut

watt/HP

r.p.m.

mm

mm

mm

mm

mm

mm

Kg

mm

kg

	watt/HP	r.p.m.	mm	mm	mm	mm	mm	mm	Kg	mm	kg
Mercurio	150/0,20	230V 50/60 Hz F+N	320	210	300	173	355	-	5	390x300x440	6
Mercurio VV	150/0,20	230V 50/60 Hz F+N	280 ÷ 750	210	300	173	355	-	5	390x300x440	6
Mercurio con leva	150/0,20	230V 50/60 Hz F+N	320	210	300	173	385	570	6	390x300x440	7
Mercurio con leva VV	150/0,20	230V 50/60 Hz F+N	280 ÷ 750	210	300	173	385	570	6	390x300x440	7

Potencia
Potencia
Мощность

Alimentación
Alimentação
Электропитание
电源

Vueltas / minuto
Gros/min.
Обороты/мин
转速/分钟

A

B

C

D

E

Peso neto
Peso líquido
Bec netto
净重

Dimensiones embalaje
Dimensões embalagem
Размеры упаковки
包裝尺寸

Peso bruto
Peso bruto
Bec брутто
毛重



2. Facile pulizia
Easy cleaning

3. Setaccio con 2 pigne
Sieve with 2 reamers

4. Pigna piccola
Reamer Small

5. Pigna grande
Reamer big



MERCURIO



TRITON

tritaggiaccio ice crushers



- Con Triton si può ottenere il ghiaccio tritato in varie dimensioni con una semplice regolazione del coltello: Ghiaccio sminuzzato finemente per le tradizionali granite. Ghiaccio in dimensioni più grandi per la preparazione di cocktail o per guarnire piatti freddi di portata o esposizione.
 - Micro di sicurezza sulla bocca di carico.
 - Micro di sicurezza sulla vaschetta di raccolta del ghiaccio.
 - Bocca in alluminio brillantato.
 - Componenti e minuterie in acciaio inox.
 - Struttura portante in alluminio e acciaio.
 - Mantello e vaschetta di raccolta in materiale plastico termoformato alimentare.
 - Cinghia multirighe a basso assorbimento di potenza.
- Triton allows to crush ice in different sizes by adjusting the blade:
Finely crushed ice for the traditional Italian granitas.
Flakes for frozen cocktails or to serve or display cold dishes.*
- Safety microswitch on the feeding mouth.
 - Safety microswitch on the collecting tray.
 - Polished aluminium feeding mouth.
 - Stainless steel parts and details.
 - Aluminium and stainless steel internal structure.
 - Body and tray are made from thermoformed alimentary plastic.
 - Ribbed belt for low power absorption.



1.



2.



3.

1. Manopola per la regolazione dello spessore di taglio
Cut thickness adjusting knob
2. Vaschetta con micro
Collecting tray with microswitch
3. Micro su leva
Microswitch on the lever

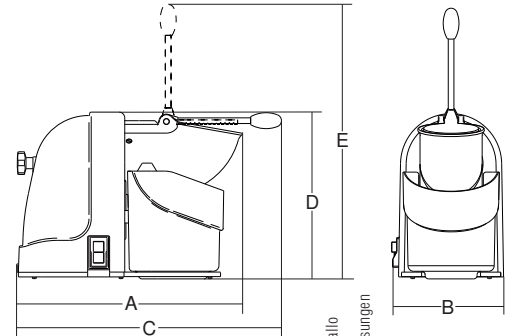

	Potenza Power Spannung Puissance	Alimentazione Power source Betriebsspannung Alimentation	Motore Motor Moteur	Giù/coltello Blade speed Drehungen des Messer Tours lame	Spessore max. ghiaccio tritato Crushed ice max thickness Zerkleinertes Eis Maximaldicke Épaisseur max glace broyée	Capacità vaschetta Capacity bowl Inhalt wanne Capacité bac	A	B	C	D	E	Peso netto Net weight Nettogewicht Poids net	Dimensioni imballo Shipping Verpack, abmessungen Dim. emballage	Peso lordo Gross weight Bruttogewicht Poids brut
	watt	r.p.m.	r.p.m.	mm	lit	mm	mm	mm	mm	mm	Kg	mm	kg	
Triton	350	230V 50/60 Hz F+N	12000	1500	10	2	365	210	465	295	480	8,5	540x280x310	10

	Potencia Potência Мощность 功率	Alimentación Alimentação Электропитание 电源	Motor Motor Двигатель 电机	Vuellos cuchillos Giros lâminas Скорость вращения ножей 刀片转速	Espeesor max hielo tritado Espessura max de gelo tritado Дроблений лед толщиной 碎冰最大厚度	Capacidad recipiente Capacidade recipiente Объем бункера 容量	A	B	C	D	E	Peso líquido Peso líquido Вес нетто 净重	Dimensiones embalaje Dimensões embalagem Размеры упаковки 包装尺寸	Peso bruto Peso bruto Вес брутто 毛重
--	--	---	-----------------------------------	---	---	--	---	---	---	---	---	---	---	--



NO RD KAPP

tritaggiaccio

ice crushers



- Spacca ghiaccio professionale, strumento indispensabile nel bar per la preparazione di drink e frozen, e nel ristorante per l'esposizione di pesce o pietanze fresche.
- Riduce in scaglie qualsiasi cubetto di ghiaccio prodotto da fabbricatore fino ad una misura di mm 40x40 a -3°C.
- Previsto di regolazione sullo scarico, permette di gestire la grandezza media delle scaglie
- Corpo macchina in alluminio estruso, bicchiere in acciaio inox, bocca di lavorazione in ABS alimentare e coltelli ghiaccio in acciaio.
- Motore ventilato con trasmissione ad ingranaggi, per un servizio prolungato, micro interruttore sul coperchio per la massima sicurezza dell'operatore.

- Professional ice crusher, an indispensable bar tool for preparing drinks and frozen cocktails and in the restaurant for displaying fish or fresh foods.
- Crushes any ice cubes made with an ice cube machine up to 40x40mm at -3° C.
- Its discharge adjustment lets you regulate the average size of the crushed ice.
- Extruded aluminium body, stainless steel container, food-grade ABS opening and s/steel blades.

- Ventilated motor with gear transmission for prolonged use, micro-switch on the lid for maximum operator safety.





1. Leva per la regolazione dello spessore del ghiaccio
Adjustable lever ice thickness

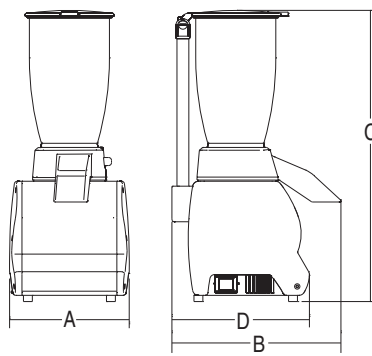

2. Coltelli
Blades



	Potenza Power Spannung Puissance	Alimentazione Power source Betriebsspannung Alimentation	Giri/coltello Blade speed Drehungen des Messer Tours lame	Capacità bicchiere Jug capacity Kapazität Capacité verre	Capacità vaschetta Capacity bowl Inhalt wanne Capacité bac	A	B	C	D	Peso netto Net weight Nettogewicht Poids net	Dimensioni imballo Shipping Verpack. abmessungen Dim. emballage	Peso lordo Gross weight Bruttogewicht Poids brut
	watt		r.p.m.	lt	lt	mm	mm	mm	mm	Kg	mm	kg
Nordkapp	150	230V 50/60 Hz F+N	800	3	2	205	285	491	235	5,2	410x280x560	8

	Potencia Potência Мощность 功率	Alimentación Alimentação Электропитание 電源	Vueltas cuchillos Giros lâminas Скорость вращения ножей 刀片转速	Capacidad vaso Capacidade copo Объём стакана 容量	Capacidad recipiente Capacidade recipiente Объём бункера 容量	A	B	C	D	Peso neto Peso líquido Вес нетто 淨重	Dimensiones embalaje Dimensões embalagem Размеры упаковки 包裝尺寸	Peso bruto Peso bruto Вес брутто 毛重
												
												



MODULO

- spremiagrumi / citrus juicers
- frullatore / blender
- rompighiaccio / ice crushers
- frappè / drink mixers



Gruppi bar modulari studiati per offrire un comodo e funzionale aiuto in ogni condizione di spazio.

- Corpo macchina in alluminio estruso e fianchi in ABS.
- Potenti motori con ventilazione forzata.
- Frullatore, frappè, rompighiaccio e spremiagrumi mantengono le caratteristiche tecniche e originali della macchina singola.

- AL = spremiagrumi Apollo con leva
- OQ = frullatore Orione con bicchiere Quadro
- N = rompighiaccio Nordkapp
- S = frappè Sirio

Modular bar groups designed to offer comfortable and functional assistance in any type of space.

- Machine body in extruded aluminium and sides in ABS.
- Powerful motor with forced ventilation.
- Blender, drink mixer, ice crusher and citrus juicer have the same technical and original features as the individual machines.

- AL = citrus juicers Apollo with lever
- OQ = blender with square glass Orione
- N = ice crushers Nordkapp
- S = drink mixers Sirio



MODULO 1 AL



MODULO 2 ALOQ



MODULO 2 ALN



MODULO 2 ALOQN



MODULO 3 ALOQN



MODULO 4 ALOQNS



1. Setaccio con 2 pigne
Sieve with 2 reamers



2. Bicchieri facilmente smontabili per la pulizia
Disassembled containers for cleaning



3. Bicchieri quadri impilabili
Stackable square glass

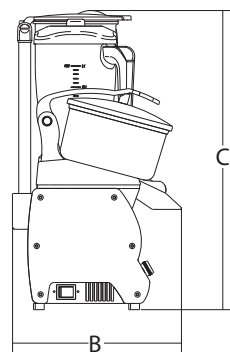
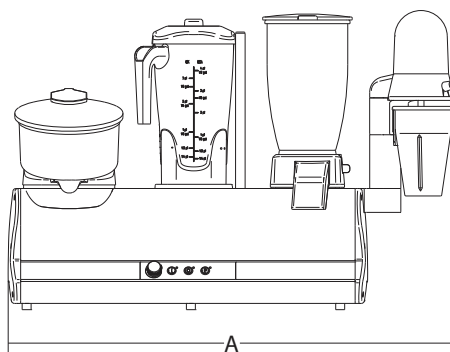

	Potenza Power Spannung Puissance	Alimentazione Power source Betriebsspannung Alimentation	Giri/min. Revolutions/min. Kreislaufl./min. Tours./min.	A	B	C	Peso netto Net weight Nettogewicht Poide net	Dimensioni imballo Shipping Verpack. abmessungen Dim. emballage	Peso lordo Gross weight Bruttogewicht Poide brut
	watt		r.p.m.	mm	mm	mm	Kg	mm	kg
Modulo 1 AL	150	230V 50/60 Hz F+N	320	202	242	370	4,2	290x380x395	6
Modulo 2 ALOQ	150-750	230V 50/60 Hz F+N	320 / 8.000÷16.000	402	242	486	9,2	380x500x590	11
Modulo 2 ALN	150-150	230V 50/60 Hz F+N	320 / 800	402	283	495	9,5	380x500x590	11,5
Modulo 2 OQN	750-150	230V 50/60 Hz F+N	8.000÷16.000 / 800	402	283	495	10,2	380x500x590	12
Modulo 3 ALOQN	150-750-150	230V 50/60 Hz F+N	320 / 8.000÷16.000 / 800	602	283	495	13,7	380x705x590	16
Modulo 4 ALOQNS	150-750-150-100	230V 50/60 Hz F+N	320 / 8.000÷16.000 / 800 / 14.000	747	283	501	16,5	380x840x590	18,5



Potencia Potência Мощность 功率	Alimentación Alimentação Электропитание 電源	Vueltas / minuto Giros/min. Обороты/мин 转速/分钟	A	B	C	Peso neto Peso líquido Вес нетто 淨重	Dimensiones embalaje Dimensões embalagem Размеры упаковки 包裝尺寸	Peso bruto Peso bruto Вес брутто 毛重
--	---	--	---	---	---	--	---	--



MULTIPLIO

frullatore - spremiagrumi - frappè
blender - citrus juicer - drink mixer

- Macchina a più servizi:
frappè Sirio spremiagrumi Apollo - frullatore Dragone.
 - Motori appositamente dedicati ad ogni servizio specifico.
 - Coperture laterali che garantiscono una ottima ventilazione.
 - Facile movimentazione della macchina.
 - Facile accesso alle parti elettriche, smontando le coperture laterali, in caso di manutenzione.
-
- Multipurpose combi machine:
drink mixer Sirio, juicer Apollo, blender Dragone.
 - Separate motors for each function.
 - Side covers allow for a perfect ventilation.
 - Easy to carry.
 - Electrical parts are easily accessible for maintenance.



MULTIPLIO 3S/L

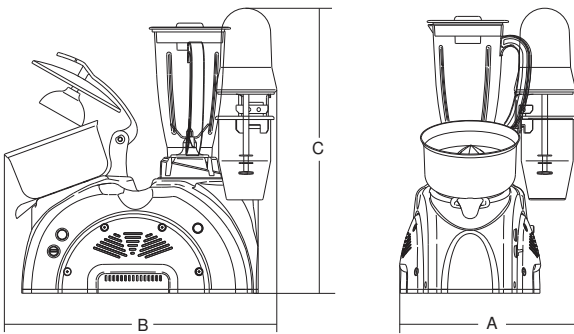

	Potenza Power Spårning Puissance	Alimentazione Power source Betriebsspannung Alimentation	Giri/min. Revolutions/min. Kreislaur/min. Tours /min.	A	B	C	Peso netto Net weight Nettogewicht Poids net	Dimensioni imballo Shipping Verpack- abmessungen Dim. emballage	Peso lordo Gross weight Brutogewicht Poids brut
	watt		r.p.m.	mm	mm	mm	Kg	mm	kg
Multiplo 2S	450-150	230V 50/60 Hz F+N	18000-320	252	445	495	6,5	380x600x600	8
Multiplo 2S/L	450-150	230V 50/60 Hz F+N	18000-320	252	445	495	7,5	380x600x600	9
Multiplo 3S	450-150-100	230V 50/60 Hz F+N	18000-320-14000	317	490	510	9	380x600x600	10,5
Multiplo 3S/L	450-150-100	230V 50/60 Hz F+N	18000-320-14000	317	490	510	9,5	380x600x600	11
Multiplo 4S	450-150-100-100	230V 50/60 Hz F+N	18000-320-14000-14000	382	490	510	10,5	580x600x600	12
Multiplo 4S/L	450-150-100-100	230V 50/60 Hz F+N	18000-320-14000-14000	382	490	510	11	580x600x600	12,5

Potencia
Potência
Мощность

Alimentación
Alimentação
Электропитание

Vueltas / minuto
Giros/min.
Обороты/мин

A B C

Peso neto
Peso líquido
Вес нетто

Dimensiones embalaje
Dimensões embalagem
Размеры упаковки

Peso bruto
Peso bruto
Вес брутто



MULTIPLIO 2S



MULTIPLIO 2S/L



MULTIPLIO 3S

ICE SPAGHETTI - SPREMIAGRUMI MANUALE



ice spaghetti - spremiagrumi citrus juice



ICE SPAGHETTI

- Apparecchi con struttura in alluminio e cremagliera cromata, sono caratterizzati da un design lineare ed un funzionamento semplice. Entrambi sono dotati di particolari completamente smontabili per una pulizia più veloce ed accurata.
- Ice spaghetti: con tre diversi bicchieri in alluminio lucidato, si possono realizzare coppe curate nei minimi particolari.
- Spremiagrumi manuale: con pigna, imbuto e coperchio in acciaio inox 304, permette di spremere gli agrumi con una semplice pressione della leva.

- With their aluminium construction and chrome rack, they feature a simple design and are easy to use. Both can be disassembled for a quicker and more accurate cleaning.
- Ice Spaghetti: with three different polished aluminium moulds, you can create elaborate ice-cream cups.
- Manual squeezer: 304 stainless steel cone, funnel and lid, it allows to squeeze citrus by simply pressing the lever.

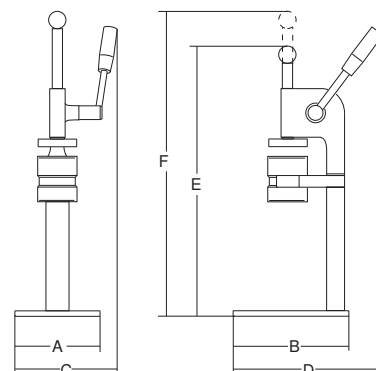

Dimensioni interne bicchiere
Mould inside dimensions
Innere Beihälter Abmes.
Dim. intérieure verre

Peso netto
Net weight
Nettogewicht
Poids net

Dimensioni imballo
Shipping
Verpack. abmessungen
Dim. emballage

Peso lordo
Gross weight
Brutogewicht
Poids brut

		A	B	C	D	E	F			
	mm	mm	mm	mm	mm	mm	mm	Kg	mm	kg
Ice Spaghetti	ø 65x80	170	200	205	245	440	520	3,5	520x220x230	4
Spremiagrumi Manuale	-	170	200	205	245	440	520	3,5	520x220x230	4

Dimensiones internas vaso
Dimensao internas copo
Внутренний размер стакана
罐口内部尺寸

Peso neto
Peso líquido
Вес нетто
淨重

Dimensiones embalaje
Dimensões embalagem
Размеры упаковки
包裝尺寸

Peso bruto
Peso bruto
Вес брутто
毛重

1. Spaghetti
Spaghetti
ø mm 2,5

2. Tagliatelle
Noodles
mm 8x2

3. Asparagi
Asparagus
mm ø 15,5



SPREMIAGRUMI MANUALE

BICCHIERI / MOULDS

DISTRIBUZIONE ESCLUSIVA | EXCLUSIVE DISTRIBUTION

Da oltre 45 anni azienda leader nel settore delle attrezzature per i professionisti della cucina, Sirman si è sempre distinta nel mercato per la grande attenzione rivolta alle innovazioni della tecnica nel settore della ristorazione. Proprio per questo all'interno della sua vasta gamma di produzione, trovano spazio nomi di spicco dell'alta tecnologia - come i forni a microonde Panasonic, le affettatrici Scharfen, il rivoluzionario Pacojet e altri gioielli della tecnica applicata all'arte di cucinare - che Sirman distribuisce in esclusiva per l'Italia dopo averli testati in collaborazione con i migliori tecnici e i più affermati chef del momento.

A leader in the professional kitchen equipment sector for over 45 years, Sirman has always been outstanding because of the great attention it has always paid to technical innovation in the restaurant business. For this precise reason within the huge range of proposals the famous names of high technology can be found - like the Panasonic microwave ovens, Scharfen slicers, the revolutionary Pacojet and other valuable technological gems applied to the art of cooking - of which Sirman is the exclusive distributor in Italy, after having tested them in collaboration with the best technicians and the best known chefs of the moment.





SC HARFEN

affettatrici
slicing machines

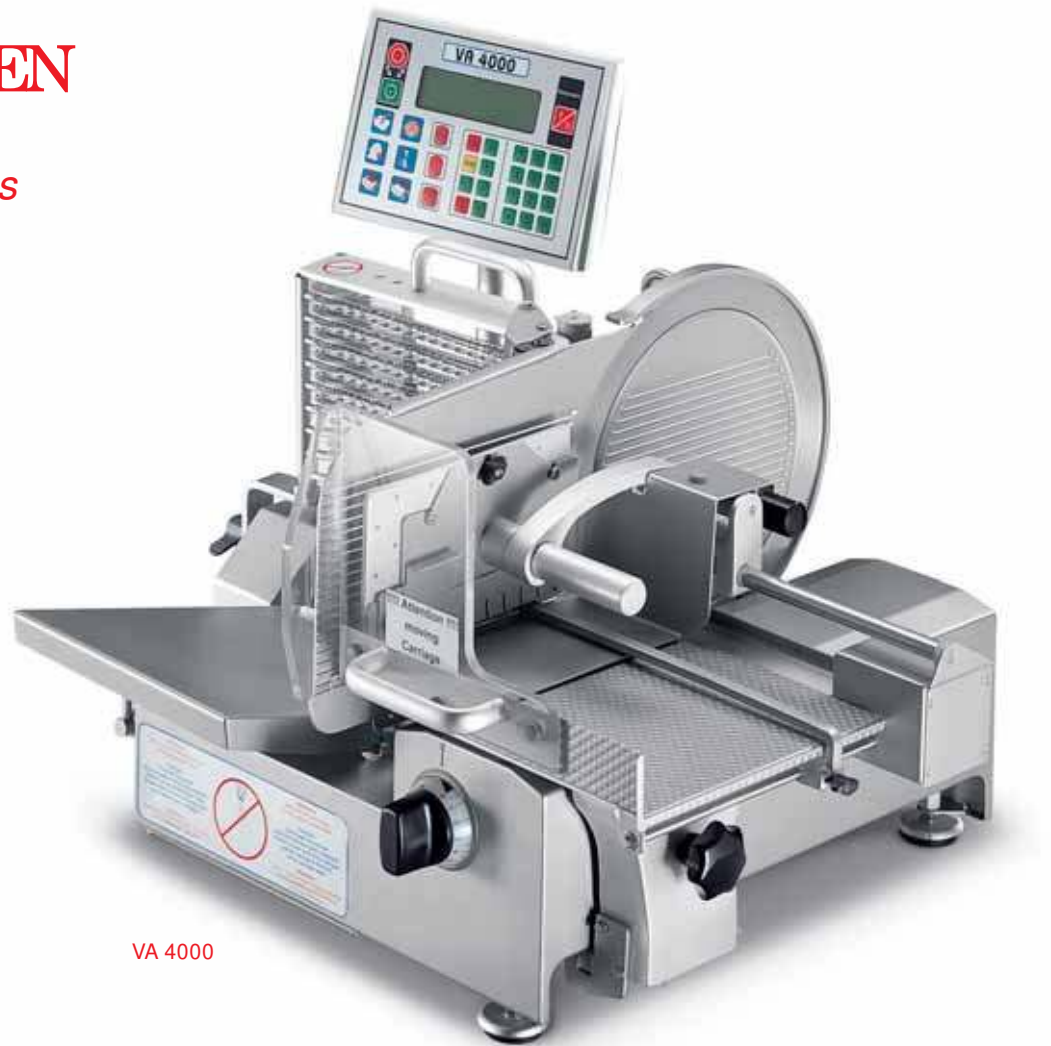

VA 4000

- La VA 4000 è un'affettatrice completamente automatica, pratica ed affidabile.
- Le eccezionali caratteristiche tecniche permettono di ottenere un'ordinata disposizione della merce. È facilmente programmabile per altissimi rendimenti, conseguiti tramite la moderna tecnologia che sta alla base della fabbricazione.
- La VA 4000 è caratterizzata da un utilizzo economicamente vantaggioso: grandi quantità di prodotto vengono affettate e porzionate.
- La lavorazione è sempre igienica ed accurata: le fette possono avere un diametro minimo di 50mm e massimo di 200.
- Le punte del pressamerce permettono un fissaggio ottimale del prodotto da tagliare; il carro, inoltre, dà la possibilità di ottenere un taglio comodo e razionale, che permette di risparmiare tempo e fatica.
- L'affettatrice è dotata di uno sgancio carrello per l'uso manuale.
- La base della macchina è saldata e gli spigoli sono arrotondati, in modo da permettere una pulizia facile e rapida.
- Le diverse funzioni sono rappresentate simbolicamente sulla pulsantiera comandi e riprodotte sul display della stessa.

Caratteristiche di resa

- 25-55 fette al minuto.
- 99 memorie, con possibilità di definire spessore di taglio, modo di disposizione delle fette e velocità di carrello.
- Telaio a catena con capacità di portata da un minimo di 50 mm fino a un massimo di 200 mm.
- Lama mossa da trasmissione ad ingranaggi che assicura una perfetta resa anche nei lavori continui.

- *The VA 4000 is a reliable, handy, completely automatic slicing machine. Its exceptional technical features allow to get an orderly stacking of slices. It is easily programmable for high output thanks to the modern technology that lies at the heart of its manufacturing.*
- *The VA 4000 features an economically profitable use: large quantities of product are sliced and proportioned. Processing is always hygienic and accurate: slices can have a diameter from 50 to 200 mm maximum.*
- *The gripping points of the meat press allow a perfect fixing of the product to be cut; besides, the hopper makes possible an easy and functional cutting, thus saving time and effort.*
- *The base of the machine is welded and round-edged for easy and quick cleaning.*
- *Different functions are symbolized on the control panel and shown on the display.*

Output features

- *25-55 slices per minute.*
- *99 memories with the possibility to pre-set cut thickness, the way of stacking slices and carriage speed.*
- *Chain loom which handles slices from 50 mm up to a maximum of 200 mm diameter.*
- *Gear driven blade to assure a perfect output also in continuing operations.*

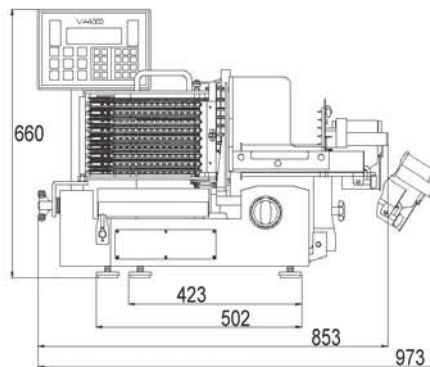
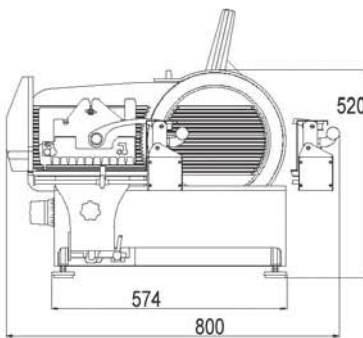

VA 4000 AT

	watt	mm	mm	mm	mm	mm	mm	mm	mm	Kg	mm	kg	
VA 4000	600	400V + N	330	10	255x195	-	360x275	530x275	360x275	800x973 h.660	80	1140x840x840	108
VA 4000 AT	600	400V + N	330	10	255x195	880x220	-	530x275	360x275	1320x973 h.1330	90	1140x840x840	118
Cavalletto / Trestle	-	-	-	-	-	-	-	-	-	-	30	740x830x960	38

Potencia absorbida
Required power
Leistungsaufnahme
Puissance absorbée
Alimentazione trifase
Power source three-phase
Betriebs dreiphasig
Alimentation triphasé

Ø Lama
Ø Blade
Ø Messer
Ø Lame

Spessore taglio
Cut thickness
Schnittbreite
Épaisseur de coupe

Capacità di taglio
Cut capacity
Schmittgrösse
Capacité de coupe

Dimensioni nastro
Dimensions of the tape
Ausmaße des Bandes
Dimensions bande

Vassoio
Plate
Plateau

Dimensioni piatto grande
Dimensions of the big plate
Ausmaße des großen Tellers
Dimensions plateau grand

Dimensioni piatto piccolo
Dimensions of the small plate
Ausmaße des kleinen Tellers
Dimensions petit plateau

Dimensioni max
Overall dimensions
Abmessungen max
Dimensions max

Peso netto
Net weight
Nettogewicht
Poids net

Dimensioni imballo
Shipping
Verpack. abmessungen
Dim. emballage

Peso lordo
Gross weight
Bruttogewicht
Poids brut

Potencia absorbida
Potência absorvida
Потребляемая мощность
需求功率

Alimentación trifásica
Alimentação trifásica
Питание трехфазное
三相电源

Ø Cuchillas
Ø Lâminas
Ø Кол-во лезвий
刀片尺寸

Espesor corte
Espessura corte
Толщина нарезки
切削厚度

Capacidad de corte
Capacidade de corte
Способность нарезки
切削长度

Dimensiones cinta
Dimensões esteira
Размеры ленты
带子尺寸

Plato
Prato
Лоток
料斗

Dimensiones plato grande
Dimensões plato grande
Размеры большого лотка
大盖尺寸

Dimensiones plato pequeno
Dimensões plato pequeno
Размеры маленького лотка
小盖尺寸

Dimensiones máx
Dimensões máx
Макс. Габарит
整机尺寸

Peso neto
Peso líquido
Вес нетто
净重

Dimensiones embalaje
Dimensões embalagem
Размеры упаковки
包装尺寸

Peso bruto
Peso bruto
Вес брутто
毛重



MINNEAPOLIS

balance - scales

MINNEAPOLIS 10/2 - 20/5 - 40/10 INOX

- Bilancia digitale, portatile, da cucina.
- Costruita in acciaio inox.
- Ampio display digitale con retroilluminazione.
- Alimentazione a batteria ricaricabile.
- Unità di pesata g, lb e oz.
- Porta seriale per collegamento dati.
- Trasformatore caricabatteria incluso.

Minneapolis 20/2-5

- divisione 2 gr. fino a 4 kg
- divisione 5 gr. da 4 kg a 20 kg.

Minneapolis 40/5-10

- divisione 5 gr. fino a 8 kg
- divisione 10 gr. da 8 kg a 40 kg.

MINNEAPOLIS 30/1

- Bilancia digitale, portatile, da cucina.
- Piano appoggia merce in acciaio inox
- Ampio display digitale retroilluminato.
- Alimentazione a batteria ricaricabile.
- Funzionalità contapezzi
- Massima pesata 30 Kg divisione 1 g
- Trasformatore caricabatteria incluso.

Attenzione! Bilance per solo uso di laboratorio, non sono omologate per la vendita al dettaglio.



MINNEAPOLIS
10/2 - 20/5 - 40/10 INOX

MINNEAPOLIS 10/2 - 20/2-5 - 40/10 INOX

- Portable scale for the kitchen.
- Made from stainless steel.
- Large digital back lit display.
- Powered by rechargeable batteries.
- g, lb, oz weighin unit.
- Serial port for data transfer.
- Battery loading transformer included.

Minneapolis 20/2-5

- precision 2 gr. until 4 kg
- precision 5 gr. from 4 kg to 20 kg.

Minneapolis 40/5-10

- precision 5 gr. until 8 kg
- precision 10 gr. from 8 kg to 40 kg.

MINNEAPOLIS 30/1

- Portable scale for the kitchen.
- S/s tray.
- Large digital back lit display.
- Powered by rechargeable batteries.
- Piece counter option.
- Max weight 30 Kg division 1 g.
- Battery loading transformer included.

Warning! Scales for internal use not approved for sale



MINNEAPOLIS 30/1

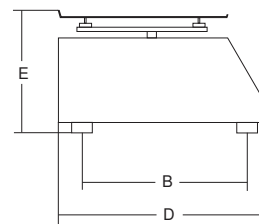
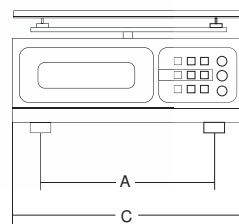

	Campo di pesata Shipping weight Abwiegelfeld Portée	Precisione di indicazione Precision Genauigkeitsgrad Précision d'indication	Dimensioni piatto Pan dimensions Abmessungen des Teller Dimensions plateau	A	B	C	D	E	Peso netto Net weight Nettogewicht Poids net	Dimensioni imballo Shipping Verpack, abmessungen Dim. emballage	Peso lordo Gross weight Bruttogewicht Poids brut
--	--	--	---	---	---	---	---	---	---	--	---

	Kg	g	mm	mm	mm	mm	mm	mm	Kg	mm	kg
Minneapolis 10/2 Inox	10	2	240 x 180	160	160	248	253	132	3,5	320x320x190	4,5
Minneapolis 20/2-5 Inox	20	2-5	240 x 180	160	160	248	253	132	3,5	320x320x190	4,5
Minneapolis 40/5-10 Inox	40	5-10	240 x 180	160	160	248	253	132	3,5	320x320x190	4,5
Minneapolis 30/1	30	1	255 x 185	190	172	255	300	110	3,8	310x355x145	4,5

	Campo de peso Campo de peso 毛重 Поле взвешивания	Precisione di indicazione Indice de precisión Точность показаний 精度	Dimensiones plato Dimensions plato Размеры тары 面积尺寸	A	B	C	D	E	Peso netto Peso líquido Вес нетто 净重	Dimensiones embalaje Dimensions emballage Размеры упаковки 包装尺寸	Peso bruto Peso bruto Вес брутто 毛重
--	--	--	---	---	---	---	---	---	---	--	--

MINNEAPO LIS



balance - scales



MINNEAPOLIS 5/1

MINNEAPOLIS 5/1 FLAT

- Bilance portatili da cucina o per lavori di precisione.
- Piano appoggia merce in acciaio inox
- Ampio display led retroilluminato.
- Indicatore di batteria scarica.
- Indicatore di sovra portata.
- Dopo 60 secondi di inattività passa automaticamente in modalità orologio.
- Unità di pesata g, lb e oz.

MINNEAPOLIS 5/1 - 5/1 INOX

- Bilance portatili da cucina o per lavori di precisione.
- Corpo in acciaio inox e piano di pesata in vetro o contenitore in acciaio per il modello inox.
- Display digitale.
- Indicatore di batteria scarica.
- Indicatore di sovra-sotto portata.
- Autospegnimento dopo 20 secondi di inattività (solo con l'utilizzo delle batterie).
- Unità di pesata g, lb e oz.

Attenzione! Bilance per solo uso di laboratorio, non sono omologate per la vendita al dettaglio.

MINNEAPOLIS 5/1 FLAT

- Portable scale for the kitchen or precision work.
- S/s tray.
- Large digital backlight display.
- Battery low indication.
- Overload indication.
- Without operation, the scale will switch to clock mode automatically in 60 seconds.
- g, lb, oz weighin unit.

MINNEAPOLIS 5/1 - 5/1 INOX

- Easy to carry scales suitable for precision work and for the kitchen.
- S/S body and glass top; S/S container on the model "INOX".
- Digital display.
- Flat battery indicator.
- Over and under weight indicator.
- Autoswitch-off after 20 seconds inactivity (only battery operated).
- g, lb, oz weighin unit.

Warning! Scales for internal use not approved for sale

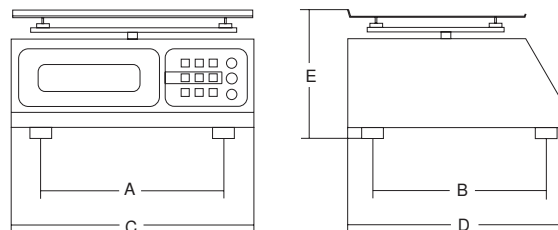

	Campo di pesata Shipping weight Abwägemaß Portée	Precisione di indicazione Precision Genauigkeitsgrad Precision of indication	Dimensioni piatto Pan dimensions Abmessungen des Teller Dimensions plateau	A	B	C	D	E	Peso netto Net weight Nettogewicht Poide net	Dimensioni imballo Shipping Verpack abmessungen Dim. emballage	Peso lordo Gross weight Bruttogewicht Poide brut
	Kg	g	mm	mm	mm	mm	mm	mm	Kg	mm	kg
Minneapolis 5/1 Flat	5	1	157x165	116	176	160	230	15	0,5	180x270x230	1
Minneapolis 5/1	5	1	∅ 150	180	220	230	190	50	1	180x270x230	1,5
Minneapolis 5/1 Inox	5	1	∅ 200 x h.60	180	220	230	190	105	0,8	240x215x135	1



MINNEAPOLIS 5/1 INOX



MINNEAPOLIS 5/1 FLAT



PACOJET

pacojet



PACOJET

Edizione limitata
Limited edition



PACOJET JUBILEE



PACOJET II

Sempre attenta alle nuove tendenze del mercato e alle esigenze della sua clientela, Sirman presenta - in esclusiva per l'Italia - PACOJET: un capolavoro della tecnica, una novità mondiale e, soprattutto, un indispensabile e insostituibile strumento di lavoro per i migliori Professionisti della Ristorazione.

Costruito in pregiato materiale con un alloggiamento in nichel-cromo, estremamente compatto, Pacojet - grazie ad una tecnica nuova e unica nel suo genere - assolve ad un compito fondamentale nelle cucine di alta qualità: "pacossare" i generi alimentari.

Ovvero: tritare, trasformare in purè, mousse e patè, generi alimentari diversi, mantecare ed emulsionare sorbetti e gelati da base surgelata. Il tutto in un'unica e sola operazione!

Con Pacojet, infatti, avrete la possibilità, in pochissimo tempo, di avere il prodotto finito e pronto per essere consumato passando quasi direttamente dal conservatore al piatto di portata. Il segreto sta tutto nell'eliminazione dei tempi di scongelamento che influiscono sui ritmi di lavoro.

In tal modo viene offerta l'opportunità di preparare in anticipo ingredienti di diversa tipologia utilizzandoli all'occorrenza subito e nelle quantità desiderate.

Inoltre, data la rapida lavorazione, le porzioni in eccesso potranno essere reinserite nella catena del freddo prima che l'azione dello scongelamento possa danneggiarle.

Ever attentive to the latest market trends and the needs of its customers, Sirman presents - exclusively for Italy - the PACOJET: a masterpiece of technique, a worldwide new release and, above all, an essential and irreplaceable tool for the leading professionals in the restaurant industry. Manufactured using quality materials, with a nickel-chrome fitting, and extremely compact, Pacojet - thanks to a new technique, unique in its class - performs a fundamental task in quality kitchens: the "pacotizin" of foods.

That is: chopping, mashing, making mousses and pâtés using different foods, whipping and emulsifying sorbets and ice cream from frozen ingredients. All in just one operation!

With Pacojet, in fact, you will be able, in a very short time, to create a finished and ready-to-consume dishes, passing almost directly from the freezer to the serving plate.

The secret lies in the elimination of defrosting times, which affect working time.

This allows different types of ingredients to be prepared in advance, and then used immediately when required and in the desired proportions. In addition, given the rapid processing speed, the excess portions can be returned to cold storage before being damaged by defrosting.



1. Creatività e ampia possibilità d'utilizzo
Creativity and a vast range of possible uses



2. Il contenitore ideale
The ideal container



3. Un passaggio nell'abbattitore e poi...
Into the blast chiller and then...



4. ...tutto nel congelatore!
...all in the freezer!



5. Pronto da pacossare
Ready to be "pacotize"



6. Da 1 a 10 porzioni di sapore
From 1 to 10 portions of flavour

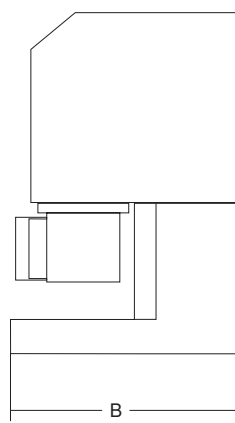
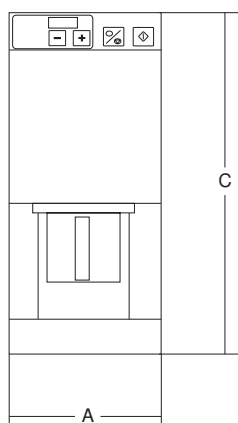

7. kit di lame per alimenti freschi
Set of knives for fresh food

	Potenza Power Spannung Puissance	Alimentazione Power source Betriebsspannung Alimentation	Giri/lama Blade speed Drehungen des Messer Tours lame	Pressione aria Air pressure Luftdruck Pression air	Capacità bicchiere Glass capacity Becker-Fassungsvermögen Capacité bol	Temperatura di lavorazione Processing temperature Arbeit-Temperatur Température de travail	A	B	C	Peso netto Net weight Nettogewicht Poids net	Dimensioni imballo Shipping Verpack-abmessungen Dim. emballage	Peso lordo Gross weight Bruttogewicht Poids brut
	Watt	r.p.m.	bar	lt	°C	mm	mm	mm	Kg	mm	kg	
Pacojet	1000	230V/50Hz	2000	1,2	0,8	da -18°C a -22 °C	200	360	500	13	300x600x460	16
Pacojet Jubilee	1000	230V/50Hz	2000	1,2	0,8	da -18°C a -22 °C	200	360	500	13	300x600x460	16
Pacojet II	950	230V/50Hz	2000	1,2	0,8	da -18°C a -22 °C	200	360	500	15,7	300x600x460	19

	Potencia Potência Мощность 功率	Alimentación Alimentação Электропитание 電源	Vueltas cuchillos Giros lâminas Электровращения 刀片转速	Presión aire Pressão ar Давление воздуха 气压	Capacidad vaso Capacidade copo Объем стакана 容器容积	Temperatura de elaboración Temperatura elaboração Температура обработки 加工温度	A	B	C	Peso neto Peso líquido Вес нетто 淨重	Dimensiones embalaje Dimensões embalagem Размеры упаковки 包装尺寸	Peso bruto Peso bruto Вес брутто 毛重
--	--	---	---	--	--	---	---	---	---	--	---	--



IH 27 - IH 35 - IH 35 WOK - PI 5.0 KW

piastre ad induzione induction hobs

- Facilmente installabili in qualsiasi piano liscio presente in cucina, nei ristoranti e nelle sale da pranzo come dimostrazione, o la preparazione di piatti particolari di fronte ai clienti, grazie all'assenza di fumi e odori.
- Dotate di pulsantiera digitale graduata.
- Estremamente facili da utilizzare e da pulire.
- Superficie di cottura pratica da pulire.
- Massima sicurezza grazie alla superficie di cottura che non si riscalda.
- Risparmio energetico grazie alla velocità di riscaldamento e all'elevata resa.
- Non sono previsti tempi di pre-riscaldamento ed il consumo di energia si blocca non appena la pentola viene rimossa dal piano.

- *The induction hobs are easy to install on every working surface in kitchens, restaurants or dining rooms; thanks to the absence of fumes they are perfect for public cooking performances or when the preparation is made in view of customers.*
- *Graduated digital controls.*
- *Extremely easy to use and to clean.*
- *Cooking surface makes cleaning easy.*
- *Safe operations are ensured by the cooking surface which is never heating up.*
- *Induction hobs are energy saving thanks to heating efficiency and no need to heat up.*
- *Electric absorption is stopped when the pan is removed from the hob surface.*



PI 5.0 KW

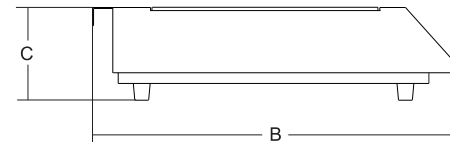
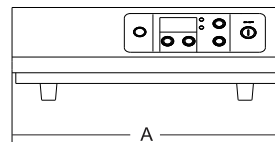

	Potenza Power Spannung Puissance	Alimentazione Power source Betriebsspannung Alimentation	Sup. utile Useful surface Nutzfläche Surface utile	A	B	C	Peso netto Net weight Nettogewicht Poids net	Dimensioni imballo Shipping Verpack. abmessungen Dim. emballage	Peso lordo Gross weight Bruttogewicht Poids brut
	Watt		mm	mm	mm	mm	Kg	mm	kg
IH 27	2700	230V/50Hz	280x280	323	370	105	4	360x425x130	4,5
IH 35	3500	230V/50Hz	280x280	330	425	105	5	385x475x145	5,5
IH 35 Wok	3500	230V/50Hz	∅ 280	340	445	110	7,3	410x505x160	8
PI 5.0 Kw	5000	400V/50Hz	320x320	320	495	135	8,8	570x400x320	12

Potencia
Potência
Мощность
功率

Alimentación
Alimentação
Электропитание
電源

Superficie útil
Superficie util
Пользная площадь
有用表面

A B C

Peso netto
Peso líquido
Без тары
淨重

Dimensiones embalaje
Dimensões embalagem
Размеры упаковки
包裝尺寸

Peso bruto
Peso bruto
Вес брутто
毛重



IH 27



IH 35 WOK



IH 35



PB 1/1 INOX



piastra buffet buffet plate



PB 1/1 INOX

- Ottimo sostituto del Bagnomaria per il mantenimento in temperatura di teglie e pirofile in metallo, vetro e porcellana.
 - Pratica piastra riscaldante da buffet.
 - Robusta struttura in acciaio inox satinato.
 - Pratiche maniglie inox per una facile movimentazione anche quando calda.
 - Regolatore di temperatura da 0 a 90 °C.
 - Vetro di appoggio temperato.
 - Dimensioni vetro compatibili con GN1/1.
- *Bain - marie alternative for maintaining the temperature of trays and casserole dishes made of metal, glass and porcelain.*
 - *Hot Plate conveniently designed for buffet and table service.*
 - *Sturdy polished stainless steel frame.*
 - *Convenient handles to easily carry it.*
 - *Dial temperature control up to 90 °C (194 °F).*
 - *Gastronorm 1/1 tempered glass.*

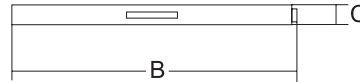
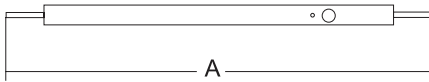

	Potenza Power Spannung Puissance	Alimentazione Power source Betriebsspannung Alimentation	Temperatura Temperature Temperatur Température	Sup. utile Useful surface Nutzfläche Surface utile	A	B	C	Peso netto Net weight Nettogewicht Poids net	Dimensioni imballo Shipping Verpack. abmessungen Dim. emballage	Peso lordo Gross weight Bruttogewicht Poids brut
	Watt		°C	mm	mm	mm	mm	Kg	mm	kg
PB 1/1 Inox	230	230V/50Hz	0 ÷ 90	530x325	610	370	45	4,5	665x400x175 n.2 PB 1/1 inox	10
	Potencia Potência Мощность 功率	Alimentación Alimentação Электропитание 電源	Temperatura Temperatura Температура 温度	Superficie útil Superficie útil Полезная площадь 有用表面	A	B	C	Peso netto Peso líquido Вес нето 净重	Dimensiones embalaje Dimensões embalagem Размеры упаковки 包裝尺寸	Peso bruto Peso bruto Вес брутто 毛重



SR-42GHXN - SR-UH36N



cuociriso rice cookers

Veloci e pratiche, offrono risultati eccellenti in poco tempo, a cottura terminata il riso può rimanere per diverse ore nel cuociriso in modalità di mantenimento temperatura. La pentola interna in materiale antiaderente è asportabile per la pulizia. Il coperchio è facilmente apribile e sono pratiche da maneggiare grazie alla loro conformazione. Ideali per hot buffets, pub, self service, mense, ristoranti e take aways.

Easy-to-use rice cookers that give you excellent result in a few minutes. With machine set on "keep warm", cooked rice can remain inside the cooking pan for several hours. The non-stick pan is removable for cleaning. The lid can be easily opened. Both are designed to be easy to handle and move around the kitchen. Sirman rice cookers are perfect for hot buffets, pubs, traditional and self service restaurants, canteens and take-aways.



SR-UH36N

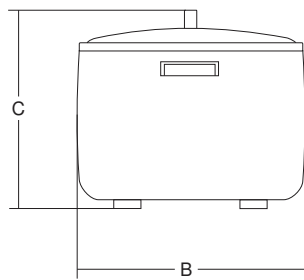
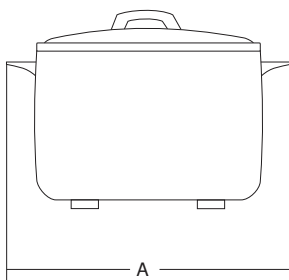

Potenza assorbita
Required power
Leistungsverbrauch
Puissance absorbée

Capacità
inside volume
Garrainvolumen
Capacité

Porzioni
Portions
Portionen

Tempo max. di mantenimento
Max time period for upkeep
Max. Gährungsdauer
Temps max. de maintien au chaud

A B C

Peso netto
Net weight
Nettogewicht
Poids net

Dimensioni imballo
Shipping
Verpack. abmessungen
Dim. emballage

Peso lordo
Gross weight
Bruttogewicht
Poids brut

		Watt	lit	n.	h.	mm	mm	mm	Kg	mm	kg
SR-UH36N	Cottura / Cooking	1400									
	Mantenimento temperatura Keep warm	124	3,6	20	12	430	385	350	8	430x430x400	9
SR-42GHXN	Cottura / Cooking	1400									
	Mantenimento temperatura Keep warm	147	4,2	23	5	430	360	300	6	430x430x280	7

Potencia absorbida
Potencia absorbida
需求功率

Capacidad
Capacidade
 вместимость
容積

Raciones
Porções
Кол-во порций
比例

Tempo máx. de mantenimiento
Tempo máx. de mantenimiento
Макс. Время хранения
最长保温期

A B C

Peso netto
Peso líquido
Вес нетто
净重

Dimensiones embalaje
Dimensions emballage
Размеры упаковки
包裝尺寸

Peso bruto
Peso brutto
Вес брутто
毛重



SR-42GHXN



NN CF771 S

forno a microonde microwave oven



- Forno combinato, perfetto complemento per qualsiasi esigenza grazie alle 3 diverse modalità di impostazioni: microonde, grill e convezione.
- La funzione grill, ottenuta con tubi al quarzo, grazie ai tre livelli di potenza, permette la rosolatura di numerosi tipi di piatti.
- La combinazione tra microonde e grill rende il forno versatile anche per la realizzazione di cotture complete.
- *Combined oven, the ideal accessory for all your needs, thanks to 3 different setting modes: microwave, grill and convection.*
- *The grill function, obtained with quartz pipes, thanks to the three power levels, allows you to brown a variety of dishes.*
- *The microwave-grill combination makes the oven versatile, to also perform complete cooking.*

- max
- alta/high
- media/medium
- scongelamento/defrost
- bassa/low
- mantenimento/keep warm

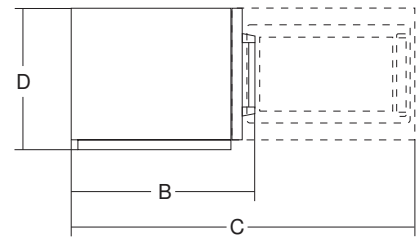
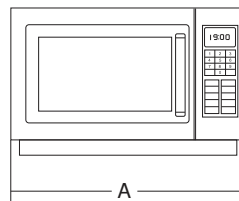

Potencia absorbida
Required power
Leistungsaufnahme
Puissance absorbée

Potencia resa
Output power
Ausgangsleistung
Puissance restituée

Livelli di potenza microonde
Microwaves power levels
Mikrowellen Leistungsstufen
Niveaux de puissance micro-ondes

Livelli di potenza grill
Grill power levels
Grill Leistungsstufen
Niveaux de puissance Grill

Timer
Timer
Schaltuhr
Minuteriees

Volume
Volume
Volumen
Volumer

Dimensioni interne
Inner dimensions
Garraumabmessungen
Dimensions intérieures

A B C D

Peso netto
Net weight
Nettogewicht
Poids net

Peso lordo
Gross weight
Bruttogewicht
Poids brut

	Watt	Watt	Watt	Watt	min.	lt	mm	mm	mm	mm	Kg	kg	
NN CF771S	max 2700 microw. 850 grill 1300 conv. 1450	microw. 1000 grill 1270 conv. 1400	1000 600 440 270 250 100	1270 950 700	90	27	354x343 h. 205	529	494	885	326	20	23

Potencia absorbida
Potência absorvida
Погребляемая мощность
帶茶功率

Potencia de rendimiento
Potência de rendimento
Отдаваемая мощность
输出功率

Niveles de potencia microondas
Níveis de potência microondas
Микроволновые печи уровней власти
微波功率水平

Niveles de potencia grill
Níveis de potência grade
уровнях Мощности гриля
功率级别烧烤

Temporizador
Timer
Таймер
定时器

Volume
Volume
Объем
体积

Dimensiones internas
Dimensões internas
Внутренние размеры
内部尺寸

A B C D

Peso neto
Peso líquido
Вес нетто
淨重

Peso bruto
Peso bruto
Вес брутто
毛重



NE 1027-1037-1037 SELF



forni a microonde microwave ovens

Forni dotati di un sistema di propagazione delle microonde dal basso verso l'alto che permette uniformità e celerità di cottura. Dimensioni camera 1/2 gastronorm. Involucro esterno e camera di cottura in acciaio inossidabile per una pulitura facile e rapida. Piatto di cottura perfettamente piano in vetroceramica. **NE 1027:** Pratico selettore di potenza a 6 posizioni per cuocere, riportare in temperatura, scongelare, completamente e velocemente. **NE 1037:** 10 programmi fissi automatici, cioè modi e tempi di funzionamento che possono venire memorizzati individualmente. Possono venire richiamati fino a 20 diversi programmi automatici a piacere. Tasto (x2): con l'azionamento del tasto il tempo d'impiego viene raddoppiato. **NE 1037 SELF:** due programmi pre-regolati per porzione grande (50 sec.) e porzione piccola (30 sec.); ideale per riscaldare velocemente pasti già pronti.



NE 1037

Compact, high-powered ovens: the microwave propagation system from below upwards enables a quick and uniform cooking. Cavity dimensions of 1/2 Gastronorm. Covering and cavity are made of stainless steel for a quick and easy cleaning. Completely flat cooking plate in ceramic glass.

NE1027: Pratical power selector switch with 6 positions for cooking, heating, defrosting completely and quickly.

NE1037: 10 automatic pre-set programs, that is, way and time of cooking can be stored separately.

By simply pressing the keys, you can choose up to 20 different automatic programs. Stop/disconnection button for corrections and data input.

Key (x2): by pressing it, the working time is doubled.

NE1037 SELF: two programs pre-regulated for big portion (50 sec.) and small portion (30 sec.) ideal for quickly warming of already prepared food.

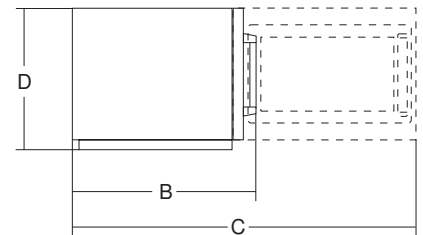
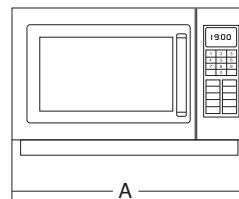

	Alimentazione Power source Netspannung Alimentation	Potenza assorbita Required power Leistungsaufnahme Puissance absorbée	Potenza resa Output power Ausgang Leistung Puissance restituée	Magnetron Magnetrone Magnétrons	Livello di potenza Power level Leistungspiegel Niveau de puissance	Timer Timer Schaltuhr Minuterie	Revisione lista programmi Programs list checking Revision Programmierliste Revision liste des programmes	Cottura a più stadi Multistage cooking Garstufein Phase de cuisson	Volume Volume Volumen Volumer	Dimensioni interne Inner dimensions Garraumabmessungen Dimensions intérieures	A	B	C	D	Peso netto Net weight Nettogewicht Poids net
	Watt	Watt	n.	Watt	min.			lt	mm	mm	mm	mm	mm	Kg	
NE 1027	230V/50Hz	1490	1000	1 x 1000 watt	variabile	30"	no	no	22	330x330x200	510	360	745	306	18
NE 1037	230V/50Hz	1490	1000	1 x 1000 watt	1000/500	90"	yes	yes 3 stage	22	330x330x200	510	360	745	306	18
NE 1037 SELF	230V/50Hz	1490	1000	1 x 1000 watt	1000/500	30-50"	no	no	22	330x330x200	510	360	745	306	18



NE 1027



NE 1037 SELF

1/1 GASTRONORM



forni a microonde microwave ovens



NE 1880

NE 1840-2140-3240:

capienti spaziosi, in grado di contenere 2 taglie Gastronorm sui due piani. Funzionamento sia su di un piano che su due, grazie al ripiano in vetroceramica e ai 4 magnetron. Apertura della porta verso il basso che diventa quindi un saldo piano di appoggio. Ideali per ristoranti, trattorie, mense, hotel e in genere per grandi cucine.

NE 1880:

forno Gastronorm digitale, dotato di 16 tasti memoria completamente programmabili con 4 livelli di potenza. Regolazione del segnale acustico, contattaci di cottura. Lavora con 4 livelli di potenza, sia a mezzo dei tasti memoria che a mezzo timer manuale di 45 minuti sui due piani. Adatto per tutte le applicazioni della grande ristorazione e catering.

NE 1840-2140-3240:

Large and spacious, capable of containing two Gastronorm trays on two shelves. Designed for cooking in one or two layers, thanks to the glass-ceramic shelves, provided as a standard fitting, and the four magnetrons. The door opens downwards and becomes a sturdy shelf. Practical and sturdy steel handles for an easy grip. Ideal for restaurants, pubs, canteens, hotels and professional kitchens in general.

NE 1880:

Gastronorm digital oven, complete with 16 fully-programmable memories with four cooking levels, i.e. 4 different power levels. Adjustable acoustic signal, cooking cycles counter. Works on four power levels, using either the memory buttons or the 45-minute manual timer, and on two shelves. Suitable for all applications in professional restaurant and catering services.

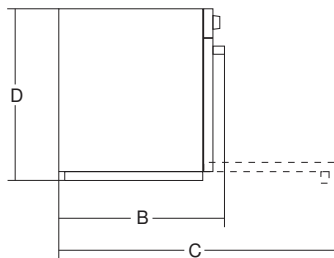
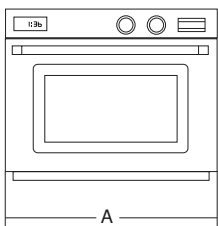

Alimentazione
Power source
Netzspannung
Alimentation
Potenza assorbita
Required power
Leistungsaufnahme
Puissance absorbée

Potenza resa
Output power
Ausgang Leistung
Puissance restituée

Frequenza microonde
Microwave frequency
Mikrowellenfrequenz
Fréquence micro-ondes

Magnetron
Magnetrone
Anzahl Magnetrons
Magnetrons

Timer
Timer
Schaltuhr
Minuterie

Contattaci
Cook cycle count display
Zählmeßeinrichtung für Betriebszeitsätze
Complete-cycles

Volume
Volume
Volumen
Volumer

Dimensioni interne
Inner dimensions
Geräuraßmessungen
Dimensions intérieures

Peso netto
Net weight
Nettogewicht
Poids net

Peso lordo
Gross weight
Bruttogewicht
Poids brut

	Watt	Watt	MHZ	n.	min.	lt	mm	mm	mm	mm	Kg	Kg			
NE 1840	230V/50Hz	3200	1800 / 900 / 340 / 170	2450	4x450W	60 / 60 / 60 / 60	si	44	565x330 h. 250 1 GN	650	526	850	471	54	58
NE 1880	230V/50Hz	3200	1800 / 900 / 340 / 170	2450	4x450W	15 / 15 / 60 / 60	si	44	565x330 h. 250 1 GN	650	526	850	471	54	58
NE 2140	400V/50Hz	3650	2100 / 1050 / 340 / 170	2450	4x525W	60 / 60 / 60 / 60	si	44	565x330 h. 250 1 GN	650	526	850	471	54	58
NE 3240	400V/50Hz	4960	3200 / 1600 / 340 / 170	2450	4x800W	60 / 60 / 60 / 60	si	44	565x330 h. 250 1 GN	650	526	850	471	54	58

Alimentación
Alimentação
Электропитание
電源
Potencia absorbida
Potência absorvida
Потребляемая мощность
需求功率

Potencia de rendimiento
Potência de rendimento
Отдаваемая мощность
输出功率

Frecuencia microondas
Frequência das microondas
Частота микроволн
微波频率

Magnetrones
Magnetrone
Манетрон
磁控管

Temporizador
Таймер
定时器

Суплациос
Суплациос
Счетчик циклов
烹任次数记载显示

Volume
Volume
Объем
体积

Dimensiones internas
Dimensões internas
Внутренние размеры
内部尺寸

Peso neto
Peso líquido
Вес нето
净重

Peso bruto
Peso bruto
Вес брутто
毛重

- alta/high
- media/medium
- bassa/low
- scongelamento/defrost



NE 1840



NE 2140 - NE 3240



1/2 GASTRO NORM

forni a microonde
microwave ovens



NE 2156/2

NE 1643 / 1843 / 2143-2 / 2146-2

- Semplici, compatti e potenti questi tre forni si distinguono per la loro facilità d'impiego.
- Dotati di timer manuale da 30 minuti, tre livelli di potenza, tasto start e display luminoso. Apertura laterale della porta. Possono essere sovrapposti.
- Adatti per tutte le applicazioni, dallo snack al piccolo ristorante, ideali per bar e paninoteche.

NE 1653 / 1656 / 2153-2 / 2156-2

Forni digitali, si distinguono dai 3 modelli visti in precedenza per la possibilità di utilizzare 20 memorie pre-programmate.

È possibile programmare i tasti memoria con 2 differenti fasi di cottura cioè 2 tempi e 2 potenze diverse (es. scongelamento-cottura).

Funzione di "blocco-sblocco programma" per funzionamento solo con memorie o anche manuale.

NE 1643 / 1843 / 2143-2 / 2146-2

- *Straightforward, compact and powerful, these three ovens stand out for their easy use.*
- *Complete with a 30-minute manual timer, three power levels, a start button and a luminous display. The door opens sideways.*
- *Suitable for stacking. Ideal for all applications, from the snack bar to the small restaurant, perfect for pubs and sandwich bars*

NE 1653 / 1656 / 2153-2 / 2156-2

Digital ovens, these differ from the three previous models in that they provide for 20 pre-programmed memories. You can program the memory buttons with two different cooking stages, i.e. 2 different times and 2 different power ratings (e.g. defrosting and cooking).

The "program lock/release" function is for working with the memories alone or in combination with the manual mode.



NE 1656



NE 1643 - NE 1846 - 1843 - NE 2146-2



1. Secondo piano estraibile per i modelli NE 2146-2 e NE 2156-2
Removable intermediate shelf for models NE 2146-2 and NE 2156-2

Regolazione intensità segnale acustico e contattici di cottura per forni a noleggio.
Memorizzazione automatica dell'ultima cottura eseguita.
Adatti soprattutto per fast-food, self-service, mense, piccoli e grandi snack.

The intensity of the acoustic signal is adjustable and there is a cooking cycle counter for ovens that are for rental. The last cooking cycle performed is automatically memorized. Suitable especially for fast-food outlets and self-service restaurants, canteens, small and large snack bars.

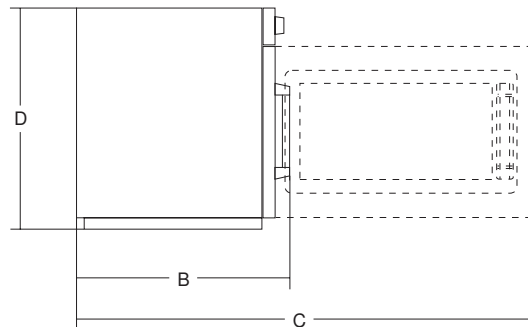
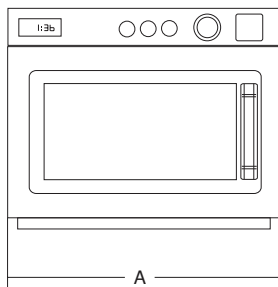

■ alta/high
■ media/medium
■ bassa/low
■ scongelamento/defrost

Alimentazione Power source Netspannung Alimentation	Potenza resa Output power Ausgang Leistung Puissance restituée	Frequenza microonde Microwave frequency Mikrowellenfrequenz Fréquence micro-ondes	Magnetron Magnetrón Anzahl Magnetrons Magnétrons	Timer Timer Schaltuhr Minuterie	Volumen Volume Volumen Volumer	Dimensioni interne Inner dimensions Garraumabmessungen Dimensions intérieures	A	B	C	D	Peso netto Net weight Nettogewicht Poids net	Peso lordo Gross weight Bruttogewicht Poids brut
--	---	--	---	--	---	--	---	---	---	---	---	---

	Watt	Watt	MHZ	n.	min.	lt	mm	mm	mm	mm	Kg	Kg		
NE 1643	230V/50Hz	2590	1600 / 800 / - / 340	2450	2x800W	25 / 30 / - / 30	18	330x310 h. 175 1/2 GN	422	508	905	337	30	33
NE 1843	230V/50Hz	2830	1800 / 900 / - / 340	2450	2x900W	25 / 30 / - / 30	18	330x310 h. 175 1/2 GN	422	508	905	337	30	33
NE 1846	230V/50Hz	2830	1800 / 900 / - / 340	2450	2x900W	25 / 30 / - / 30	18	330x310 h. 175 1/2 GN	422	508	905	337	30	33
NE 2143-2	230V/50Hz	3160	2100 / 1050 / - / 340	2450	2x1050W	25 / 30 / - / 30	18	330x310 h. 175 1/2 GN	422	508	905	337	30	33
NE 2146-2	230V/50Hz	3160	2100 / 1050 / - / 340	2450	2x1050W	25 / 30 / - / 30	18	330x310 h. 175 1/2 GN	422	508	905	337	30	33
NE 1653	230V/50Hz	2590	1600 / 800 / - / 340	2450	2x800W	15 / 15 / - / 30	18	330x310 h. 175 1/2 GN	422	508	905	337	30	33
NE 1656	230V/50Hz	2590	1600 / 800 / - / 340	2450	2x800W	15 / 15 / - / 30	18	330x310 h. 175 1/2 GN	422	508	905	337	30	33
NE 2153-2	230V/50Hz	3160	2100 / 1050 / - / 340	2450	2x1050W	15 / 15 / - / 30	18	330x310 h. 175 1/2 GN	422	508	905	337	30	33
NE 2156-2	230V/50Hz	3160	2100 / 1050 / - / 340	2450	2x1050W	15 / 15 / - / 30	18	330x310 h. 175 1/2 GN	422	508	905	337	30	33

Alimentación Alimentação Электроснабжение 电源	Potencia absorbida Potência absorvida Потребляемая мощность 需求功率	Potencia de rendimento Potência de rendimento Отдаваемая мощность 输出功率	Frequencia microondas Frequência das microondas Частота микроволн 微波频率	Magnetron Magnetrón Магнетрон 微波炉	Temporizador Timer Таймер 定时器	Volumen Volume Объем 体积	Dimensiones internas Dimensões internas Внутренние размеры 内部尺寸	A	B	C	D	Peso neto Peso líquido Вес нетто 净重	Peso bruto Peso bruto Вес брутто 毛重
---	---	---	---	--	--	----------------------------------	--	---	---	---	---	--	--



NE C1475

forni a microonde
microwave ovens



- Il forno professionale combinato non è solo un forno in grado di assolvere in modo eccellente alle diverse funzioni di forno a microonde, forno a convezione e grill. È la possibilità di utilizzare questi diversi tipi di cottura separatamente, in sequenza o in combinazione, per realizzare qualsiasi piatto in tempi rapidi e con risultati ottimali.
- Proprio nell'uso combinato è il vantaggio più importante.
- Finalmente è possibile preparare cibi perfettamente dorati e gratinati, come quelli che si ottengono con la cucina tradizionale, risparmiando 1/3 del tempo di cottura.
- È ideale per gli snack, pub, bar e per tutte le situazioni in cui la disponibilità di spazio sia ridotta, perché assolve in modo eccellente le diverse funzioni con il minimo ingombro.
- Nelle cucine professionali sostituisce la salamandra e, nei momenti di minore attività, può essere usato come forno a convezione forzata al posto di forni con dimensioni più grandi e consumi maggiori.

MICROONDE:

due magnetron forniscono una potenza resa di 1350W usufruibili con 5 livelli diversi.

GRILL:

la funzione GRILL viene realizzata con 4 tubi al quarzo regolabili con 3 livelli di potenza per garantire la massima versatilità.

CONVEZIONE:

una resistenza da 1800W abbinata ad una ventola garantisce un rapido riscaldamento della camera ed una uniformità di temperatura.

- *The Panasonic NE C1475 is far more than an excellent microwave oven, convection oven and grill all rolled into one. It lets you choose to use each cooking method separately, in sequence or in combination, to cook any type of dish in the shortest possible time and with the best possible results.*
- *The Panasonic NE C1475 really excels as a combination oven.*
- *With combination cooking, you can brown and crisp foods to get the same appetising results normally possible only with traditional cooking - but with a saving of 1/3 in cooking time.*
- *It is ideal for snack bars and all catering establishments where space saving is a prime consideration. It can easily replace the salamander in large catering kitchens, and during slack periods, can serve as a small convection fan oven in the place of bigger units with far higher energy consumption.*

MICROWAVES:

two magnetron supply a 1350 W output power in 5 different levels.

GRILL:

grill function assures highest versatility thanks to 4 quartz tubes with 3 power levels.

CONVECTION:

a 1800W heating element assures a fast heating of the chamber and temperature uniformity.

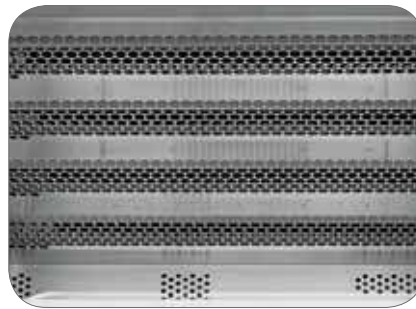
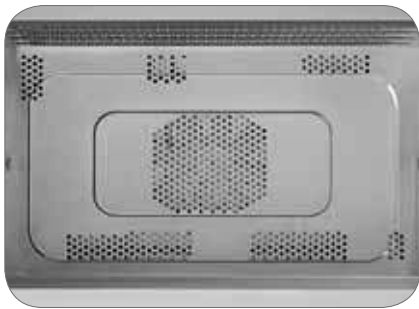

1. Convezione con Ventola e Resistenza posteriori.
Questo forno combinato Vi offre una grande e potente convezione da 1800 W tramite l'efficacia di una resistenza e una ventola sistemate sul retro del forno stesso.
Convection system with rear fan and elements
The Panasonic NE - C1475 combination oven includes a powerful 1800 W convection cooking system with one heating element and fan on the rear wall.

2. Questo forno combinato é dotato di un grill da 4 resistenze al quarzo per assicurare una doratura eccellente e velocissima.
This combination oven has a four quartz element grill for fast and even browning.

3. Memory Card su NE C 1475

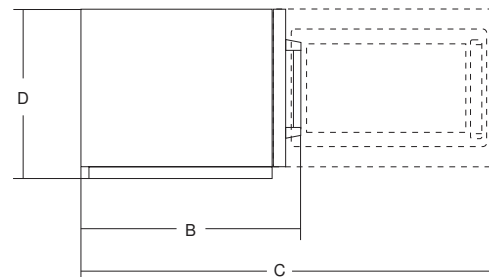
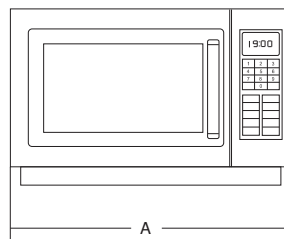

- alta/high
- media/medium
- bassa/low
- scongelamento/defrost
- cottura lenta/simmer

	Watt	Watt	Watt	Watt	min.	n.				lit	mm	mm	mm	mm	Kg	
NE C1475	3300	1350 650 420 180 240	1800 1450	1800 (100-250°C)	99 min.	99	yes	yes	yes	30	406x336 h. 217	600	545	930	383	41

Potenza assorbita max
Required power max
Leistungsaufnahme max
Puissance absorbée max

Potenza resa
Output power
Ausgang Leistung
Puissance restituée

Grill livello 1/2
Grill level 1/2
Grill Ebene 1/2
Grill niveau 1/2

Convezione
Convection cooking
Umluft
Convection

Timer
Timer
Schaltuhr
Minuteriees

Programmi automatici
Automatic programs
Automatische Programme
Programmes automatiques

Riscaldamento multistadio
Multi-stage heating
Mehrstufige Erhitzung
Chaufage multietage

Funzione preriscaldamento
Pre-heating function
Vorwärmfunktion
Fonction de préchauffage

Funzione Raffreddamento
Cooling function
Kühlfunktion
Fonction de refroidissement

Volume
Volume
Volumen
Volumer

Dimensioni interne
Inner dimensions
Garaumabmessungen
Dimensions intérieures

A

B

C

D

Peso netto
Net weight
Nettogewicht
Poids net

Potencia máx absorbida
Potencia máx absorbida
Потребляемая мощность
需菜功率

Potencia de rendimiento
Potencia de rendimiento
Отдаваемая мощность
输出功率

Grill nivel 1/2
Grill level 1/2
Гриль уровень 1/2
烤盘的层数为 1/2

Convección
Convección
Конвекция
对流烹饪

Temporizador
Timer
Таймер
定时器

Programas automáticos
Programas automáticos
Автоматические программы
自动程序

Calentamiento multietadio
Aquecimiento a multi-estágios
Многоуровневый разогрев
多级加热

Función prer calentamiento
Función pre-aquecimento
Функция предзаогрева
预热功能

Función enfriamiento
Función de resfriamento
Функция охлаждения
制冷功能

Volumen
Volume
Объем
体积

Dimensiones internas
Dimensões internas
Внутренние размеры
内部尺寸

A

B

C

D

Peso netto
Peso líquido
Вес нетто
净重



WDB 900 COMBI - WP 1000 PF M - CM1039A

forni a microonde
microwave ovens



WDB 900 COMBI



WP 1000 PF M



CM 1039 A

- Interamente in acciaio inox
- Piatto rotante in vetro temperato
- Timer 30 min.
- Selettore a 6 livelli di potenza microonde
- 2 combinazioni grill-microonde
- Programma automatico scongelamento a peso
- Ideale per la piccola ristorazione, bar e snack.

- *Stainless steel construction*
- *Tempered glass rotating plate*
- *Timer 30 min.*
- *Microwave: 6 different power levels*
- *2 grill-microwave combination*
- *Weight-based automatic defrost*
- *Ideal for small restaurants and bars*

- Potenza resa microonde 1000 Watt
- 5 livelli di potenza per una massima versatilità
- Comandi manuali per potenza e timer
- Interno ed esterno in acciaio inox
- Piatto fisso in vetroceramica
- Apertura con pratica maniglia ed ampio vetro per controllo livello di cottura

- *Output power: 1000 Watt*
- *High versatility with 5 power levels*
- *Manual controls for power and timer*
- *Stainless steel cabinet and cavity finish*
- *Ceramic glass cooking plate*
- *See-through opening door with practical handle*

- 1000 Watts
- Comandi manuali per potenza e timer
- Interno ed esterno in acciaio inox
- Piatto fisso in vetroceramica
- 5 livelli di potenza per una massima versatilità
- Apertura con maniglia ed ampio vetro per controllo livello di cottura

- *1000 Watts*
- *Manual dial controls for power & timer*
- *Stainless steel inner cavity and external structure*
- *Fixed pyroceram plate*
- *5 power levels for greater cooking versatility*
- *Pull to open door with large display window*

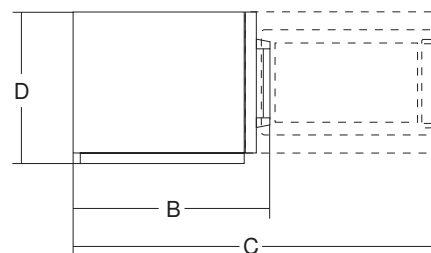
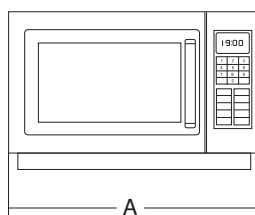

	Alimentazione Power source Netzspannung Alimentation	Potenza assorbita Required power Leistungsaufnahme Puissance absorbée	Potenza resa Output power Ausgang Leistung Puissance restituée	Frequenza microonde Microwave frequency Mikrowellenfrequenz Fréquence micro-ondes	Livelli di potenza Power level Leistungspegel Niveau de puissance	Volumen Volume Volumen Volumer	Dimensioni interne Inner dimensions Garaumabmessungen Dimensions intérieures	A	B	C	D	Peso netto Net weight Nettogewicht Poids net	Peso lordo Gross weight Bruttogewicht Poids brut
	Watt	Watt	Watt	MHZ	n.	lt	mm	mm	mm	mm	mm	Kg	Kg
WDB 900 COMBI	230V/50Hz	1400 MO 1000 GRILL	900	2450	5	25	340x344x220	483	422	735	281	14,5	16,7
WP 1000 PF M	230V/50Hz	1500	1000	-	6	25	330x360x200	520	442	790	312	17,7	19,3
CM 1039 A	230V/50Hz	1450	900	2430	5	26	336x349x225	517	412	760	297	17,5	19,3
	Alimentación Alimentação Электропитание 電源	Potencia absorbida Potência absorvida Потребляемая мощность 消費功率	Potencia de rendimiento Potência de rendimento Отдаваемая мощность 输出功率	Frequência microondas Frequência das microondas Частота микроволн 微波频率	Niveles de potencia Níveis de potência Уровень мощности 功率水平	Volumen Volume Объем 体积	Dimensiones internas Dimensões internas Внутренние размеры 内部尺寸	A	B	C	D	Peso netto Peso líquido Вес нетто 净重	Peso bruto Peso bruto Вес брутто 毛重



45 K

dispenser

shrink wrapper



- Ideati per il confezionamento di alimenti come carne, formaggio, pasta, frutta e verdura freschi; i dispenser offrono un servizio veloce e igienico nei supermercati, macellerie e gastronomie in genere, dove il commercio di prodotti freschi richiede un confezionamento giornaliero veloce e sicuro.
 - Struttura in acciaio inox.
 - Rulli e astine in alluminio anodizzato.
 - Piano riscaldante regolabile tramite termostato.
 - Profilo teflonato (non provoca fumo).
- *Designed for packing meat, cheese, pasta, fruits and vegetables; our wrapping machines offer a fast hygienic service for supermarkets, butcher's, delicatessens and wherever fresh products retail needs a quick and safe daily packaging.*
- *Stainless steel body.*
 - *Anodized aluminium rollers and rods.*
 - *Heating surface temperature adjustable by thermostat.*
 - *Teflon coated section. (do not smoke).*



1. Profilo teflonato
Teflon-coated section

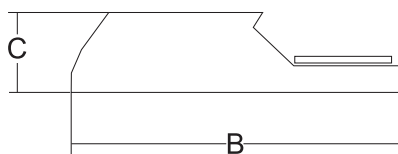
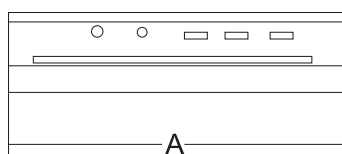

	Potenza Power Spannung Puissance	Alimentazione Power source Betriebsspannung Alimentation	Rotoli film Max. film roll Für Filmrullen max. Max. bobine film	Piano riscaldante Heating surface Heizfläche Plateau chauffant	A	B	C	Peso netto Net weight Nettogewicht Poids net	Dimensioni imballo Shipping Verpack, abmessungen Dim. emballage	Peso lordo Gross weight Bruttogewicht Poids brut
	Watt	230V/50Hz	mm	mm	mm	mm	mm	Kg	mm	kg
45K	120	230V/50Hz	400	385x125	485	600	140	5	510x610x160	6
	Potencia Potência Мощность 功率	Alimentación Alimentação Электропитание 電源	Rolls película Bobina película 取大薄膜卷	Piano calentador Plano de aquecimento 加蒸表面	A	B	C	Peso neto Peso líquido Бес нетто 淨重	Dimensiones embalaje Dimensões embalagem Размеры упаковки 包裝尺寸	Peso bruto Peso bruto Бес брутто 毛重



HW 45

rotolatore vitafilm hand wrapper

- Pratico rotolatore di vitafilm per un facile e veloce confezionamento
- Costruzione struttura in acciaio inox
- Rulli di supporto vitafilm in alluminio
- Possibilità di taglio in entrambi i versi
- Massima larghezza del rotolo vitafilm mm 450
- Massimo diametro del rotolo vitafilm mm 110
- Privo di collegamento elettrico rende lo rotolatore facile da maneggiare e da spostare
- Facile sostituzione del film.

- *Practical handwrapper for a easy and fast packaging.*
- *Stainless steel frame.*
- *Aluminium support rollers.*
- *cutting system on both sides.*
- *maximum width of film is mm 450.*
- *maximum diameter of film is mm 110.*
- *no electrical connection therefore can be easily positioned in different places.*
- *the film can be easily replaced.*

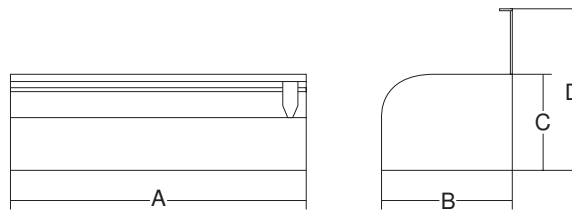

Dimensioni max rotolo film
Film roll max dimensions
Folienrollen max
Max. bobine film

A B C D

Peso netto
Net weight
Nettogewicht
Poids net

Dimensioni imballo
Shipping
Verpack. abmessungen
Dim. emballage

Peso lordo
Gross weight
Bruttogewicht
Poids brut

	mm	mm	mm	mm	Kg	mm	kg
HW45	450x110	560	210	173	2,8	540x240x210	4

Dimensiones max rollos película
Bobina película
Рулон пленки макс.
最大薄膜卷

A B C D

Peso neto
Peso líquido
Бес нетто
净重

Dimensiones embalaje
Dimensions emballagen
Размер упаковки
包装尺寸

Peso bruto
Peso brutto
Бес брутто
毛重



S 300/2 - S 400/2 - S 400/2T



sigillatrici sealers



S 300/2

Sigillatrici dal veloce e facile utilizzo sono indispensabili nella gestione degli alimenti. Possono saldare 2 mm di spessore per una lunghezza di 300 o 400 mm tutti i tipi di sacchetti in plastica per alimenti.

Il temporizzatore posto frontalmente permette la sigillatura di sacchetti con spessori diversi, mentre il modello S400/2T dotato di taglierina permette di eliminare la parte residua del sacchetto.

Fast and easy-to-use sealers are indispensable devices for food management.

These can seal all types of plastic bags for food, with thicknesses of up to 2mm and across a length of 300 or 400mm.

The timer fitted at the front is used to seal bags of different thicknesses, while model S400/2T, fitted with a cutter, eliminates the remaining parts of the bags.

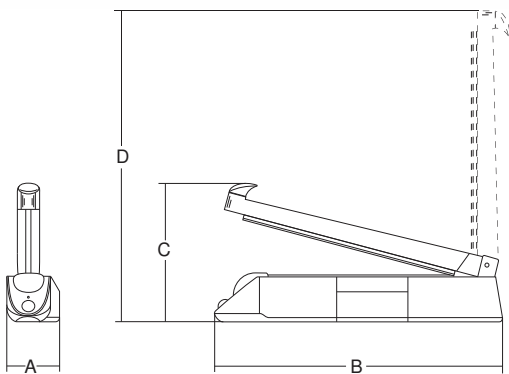

1. Timer tempo sigillatura
Timer for sealing time



2. Taglierina su modello S 400/2T
Cutter on model S 400/2T

	Potenza Power Leistung Puissance	Temperatura di sigillatura Sealing temperature Siegetemperatur Température de sceller	Tempo di sigillatura Sealing time Siegezeit Temps de sceller	Tempo di sigillatura regolato Programmed sealing time Stellbare Temps de sceller réglé	Lunghezza sigillatura Sealing length Siege-Länge Longueur de sceller	Spessore sigillatura Sealing thickness Siegestärke Épaisseur de sceller	A	B	C	D	Peso netto Net weight Nettogewicht Poids net	Materiale sigillabile Sealable materials Sieginde Werkstoff Matériel a sceller
	Watt	°C	sec.	sec.	mm	mm	mm	mm	mm	mm	Kg	
S 300/2	510	150 max	min. 0,5 - max 2,5	1,5	200 - 300	0,5	75	455	260	520	3,5	PE, PP, LDPE, PVC
S 400/2	700	150 max	min. 0,5 - max 2,5	1,5	200 - 400	0,5	75	555	260	620	4	PE, PP, LDPE, PVC
S 400/2T	700	150 max	min. 0,5 - max 2,5	1,5	200 - 400	0,5	75	555	260	620	4	PE, PP, LDPE, PVC

Potencia
Potência
Мощность
功率

Temperatura de sellado
Tempo de sigillação
Температура запайки
封袋温度

Temperatura de sellado
Tempo de sigillação
Температура запайки
封袋温度

Тiempo de sellado regulado
Tempo de sigillação
Установленное время запайки
调节封袋时间

Longitud sellado
Comprimento sigillação
Длина шва запайки
封袋长度

Espesor sellado
Espessura sigillação
Толщина шва запайки
封袋厚度

A

B

C

D

Peso netto
Peso líquido
Вес нетто
净重

Materiale para sellar
Materiais seláveis
Материал для запайки
封袋材料



S 400/2



S 400/2T



ORTOLINA

tagliaverdure manuale

manual vegetable cutter

- Tagliaverdure manuale.
- Totalmente costruita in acciaio inox.
- Piedini in gomma antiscivolo.
- Pratica e ripiegabile.
- Sei tipi di lame intercambiabili per taglio a julienne: 2; 3; 4; 5; 6 e 10 mm di larghezza
- Tre tipi di taglio: Fette; Julienne; Fette ondulate.
- Regolabile in altezza da 1 a 6 mm per fette e julienne.
- Regolabile in altezza da 1 a 4 mm per fette ondulate.

- Manual vegetable cutter.
- Completely stainless steel.
- Nonslip rubber feet.
- Functional and bendable.
- 6 different interchangeable blades for julienne cutting: 2, 3, 4, 5, 6 and 10 mm width.
- 3 different cutting possibilities: Slices; Julienne; Wavy slices.
- Adjustable thickness from 1 to 6 mm for slices and julienne.
- Adjustable thickness from 1 to 4 mm for wavy slices.

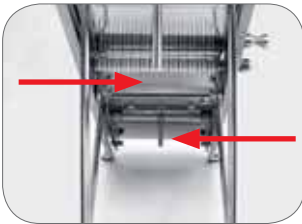

1. Leve regolazione spessore di taglio
Cutting width adjustment levers



2. Supporto verdura e lame in dotazione
Vegetable support and blades supplied



3. Max spessore di taglio 6 mm
Max cutting width 6 mm

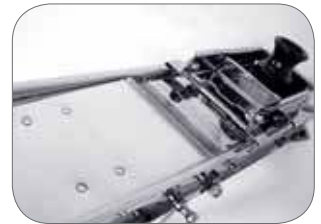

4. Min. spessore di taglio 1 mm
Min. cutting width 1 mm



5. Leva per cambio lame
Blade change lever



6. Leva per cambio lame
Blade change lever

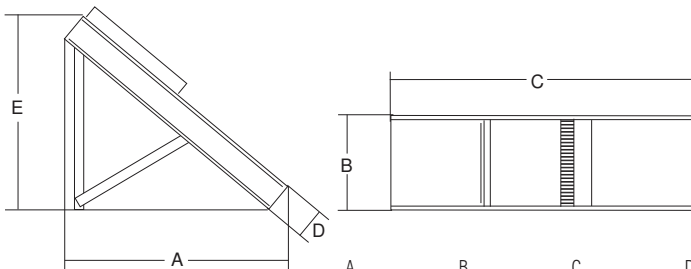

	A	B	C	D	E	Peso netto Net weight Nettogewicht Poids net	Dimensioni imballo Shipping Verpack, abmessungen Dim. emballage	Peso lordo Gross weight Bruttogewicht Poids brut
	mm	mm	mm	mm	mm	kg	mm	kg
Ortolina	370	140	405	40	240	1,7	230x150x540	2

A B C D E

Peso netto
Net weight
Nettogewicht
Poids net

Dimensioni imballo
Shipping
Verpack, abmessungen
Dim. emballage

Peso lordo
Gross weight
Bruttogewicht
Poids brut

Peso netto
Net weight
Nettogewicht
Poids net

Dimensiones embalaje
Dimensions emballagem
Размеры упаковки
包裝尺寸

Peso bruto
Gross weight
Bruttogewicht
Poids brut

SMO KERBAG

TEG I
termometro digitale
digital thermometer

Prodotto in Finlandia, SmokerBag è la soluzione innovativa per affumicare in modo semplice, salutare ed ecologico qualsiasi pietanza – carne, pesce, verdure e persino frutta e cioccolato – ogni giorno e in ogni stagione.

SmokerBag è un capiente sacchetto di alluminio pesante con un doppio fondo che contiene piccoli trucioli di legno d'ontano, sciroppo di betulla e zuccheri naturali. Quando SmokerBag viene portato a temperatura in forno o sulla griglia, queste sostanze naturali producono una leggera affumicatura del cibo racchiuso all'interno, e una cottura al cartoccio che lo mantiene sempre tenero e succoso. Nella mani dello chef, SmokerBag diventa un raffinato strumento estremamente versatile e ricco di potenzialità. Ideale per riscoprire un aroma tipicamente nordico con il gusto e la fantasia dell'arte culinaria italiana.
Dimensioni 28x42 cm

Indicazioni d'uso:

1. Inserire le pietanze nel sacchetto SmokerBag e richiuderlo, facendo attenzione che la dicitura this side down sia sempre rivolta verso il basso.
2. Metterlo nel forno preriscaldato o sulla griglia.
3. Affumicare per un tempo variabile, secondo la creatività dello chef.
4. Aprire SmokerBag con cautela, facendo attenzione alla fuoriuscita di vapore.
5. Utilizzare il sacchetto una sola volta.

ATTENZIONE:

SmokerBag non deve mai entrare in contatto con la fiamma viva.
SmokerBag non deve mai essere capovolto.
SmokerBag non è adatto al forno a microonde.

SmokerBag, a new product produced in Finland, is an innovating solution for an easy, healthy and ecological smoking of any food – meat, fish, vegetables and even fruit – in any time of the year.

SmokerBag is a large aluminium bag with a double wall containing minute chips of alder wood, birch syrup and natural sugar. When SmokerBag reaches the working temperature in the oven or on the grill, these natural ingredients produce a light smoking of food in the bag, and the baking in foil keeps it soft and juicy. SmokerBag is a fine tool in the hands of the chef, gaining benefit from its great versatility and potentials and blending a peculiar Nordic flavour with different culinary arts.

Dimensions: 28x42 cm

Instructions:

1. Put food in the SmokerBag, then close the bag. Pay attention: caption "This side down" must be on the bottom side.
2. Put the bag in the preheated oven or on the grill.
3. Smoking time depends on the chef's creativity.
4. Open the SmokerBag carefully, paying attention to issuing vapour.
5. SmokerBag can only be used once.

ATTENTION:

SmokerBag can never be on contact with blazes.
Never turn **SmokerBag** upside-down.
Never put **SmokerBag** in the microwaves oven.

Caratteristiche tecniche:

Risoluzione	0.1°C / 0.1 °F
Batterie	watt 1 x LR44 1.5V
Temperatura rilevata dall'ago	max + 300°C - min. - 50°C
Dimensioni ingombro	mm 25x150

Technical features:

Resolution	0.1°C / 0.1 °F
Battery	watt 1 x LR44 1.5V
Temperature from stem	max + 300°C - min. - 50°C
Overall dimensions	mm 25x150



PLUTO NE 7-10-20-30

planetarie planetary mixers

PLUTONE 7

- Impastatrice planetaria interamente in metallo;
 - testa alzabile per smontaggio vasca, sostituzione utensile e pulizia generale.
 - Vasca smontabile inox da litri 7.
 - 3 utensili in metallo.
 - Motore in CC con variatore di velocità.
 - Trasmissione ad ingranaggi lubrificati a grasso.
 - Microinterruttori su alzata testa.
 - Dispositivo NVR.
 - La macchina è indicata per impasti morbidi, per impasti di media consistenza (es. pane) si consiglia max 1 kg di farina.
 - NON è adatta per impasti molto duri (es. taralli).
- *Metal cast planetary mixer.*
 - *Liftable head for bowl and tools removal and easy cleaning.*
 - *Removable, S/S, 7L bowl.*
 - *3 metal tools;*
 - *D.C. motor with speed control.*
 - *Gear drive and grease lubrication.*
 - *Safety microswitch on the head.*
 - *NVR device.*
 - *Suitable for soft dough, for medium dough (for ex. Bread) it is advisable max 1 kg of flour.*
 - *NOT suitable for tough mix. (for ex. taralli).*



PLUTONE 7



PLUTONE 7

PLUTONE 10 - 20 - 30

- Protezione della vasca in filo metallico.
- Vasca in acciaio inox 304 facilmente smontabile.
- Dispositivo di sicurezza all'apertura della protezione e abbassando la vasca.
- 3 accessori di lavorazione facilmente sostituibili: spatola e gancio in fusione di alluminio frusta in fusione di alluminio e acciaio.
- Cambio meccanico a 3 velocità.
- Sistema di riduzione con ingranaggi in acciaio.
- Motore ventilato.

Plutone 10 - 20

- Solida struttura in fusione verniciata.

Plutone 30

Solida struttura in carpenteria smaltata

- Comandi con timer
 - Presa di forza.
- *Powder coated steel.*
 - *Bowl protection made from metal wire.*
 - *Easy to remove bowl made from stainless steel 304.*
 - *Safety microswitches for the lid and the bowl.*
 - *3 easy to remove metal tools: aluminium spatula and hook, steel and aluminium whisk.*
 - *3 speed gear.*
 - *Steel gear box.*
 - *Ventilated motor.*

Plutone 10 - 20

- Sturdy frame from large thickness

Plutone 30

- Enamelled metal sturdy frame
- Controls with timer
- PTO.



PLUTONE 10



PLUTONE 20



PLUTONE 30



Plutone 30

1. Tramoggia per aggiunta ingredienti
Feed tray for add ingredients



Plutone 10 - 20



Plutone 30



Plutone 7

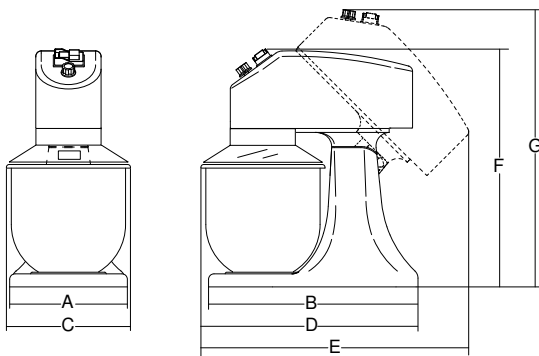

PLUTONE 7

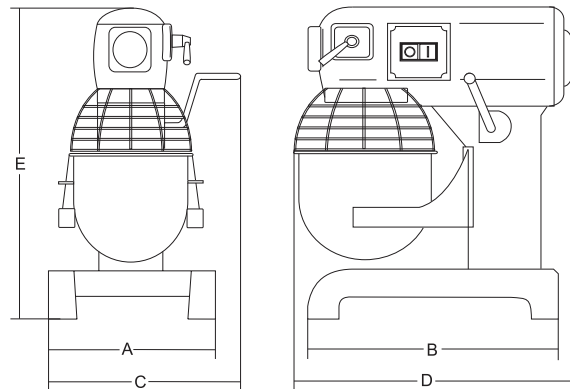

PLUTONE 10-20-30

	Potenza Power Leistung Puissance	Alimentazione Power source Betriebsspannung Alimentation	Giri frusta Whisk revolutions Schneebesenumdrehungen Tours fouet	Capacità vasca Tank capacity Becken Kapazität Capacité cuve	A	B	C	D	E	F	G	Peso netto Net weight Nettogewicht Poids net	Dimensioni imballo Shipping Verpack. abmessungen Dim. emballage	Peso lordo Gross weight Bruttogewicht Poids brut
	watt		giri/min.	lt	mm	mm	mm	mm	mm	mm	mm	kg	mm	kg
Plutone 7	280	230V/50Hz	75 ÷ 660	7	220	285	240	410	450	437	510	18	470x320x500	21
Plutone 10	450	230V/50Hz	1 = 108 2 = 195 3 = 355	10	360	345	440	500	630	-	-	40	470x550x750	55
Plutone 20	1100	230V/50Hz	1 = 97 2 = 220 3 = 316	20	420	440	515	560	770	-	-	99	570x630x920	125
Plutone 30	1500	230V/50Hz	1 = 93 2 = 167 3 = 285	30	580	660	630	650	1160	-	-	125	750x730x1300	150

	Potencia Potência Мощность 功率	Alimentación Alimentação Электропитание 电源	Vueltas batidor Giros batedor Обороты Венчик 搅拌器转速	Capacidad fina Capacidade recipiente Объем бункера 容量容积	A	B	C	D	E	F	G	Peso neto Peso líquido Вес нетто 净重	Dimensiones embalaje Dimensões embalagem Размеры упаковки 包装尺寸	Peso bruto Peso bruto Вес брутто 毛重
--	--	---	---	--	---	---	---	---	---	---	---	--	---	--



ELDO RADO

friggitrici
fryers



ELDORADO 8X2 R

- Costruita in acciaio inox.
- Cestello rinforzato.
- Termostato e sonda cut-off di sicurezza e pulsante di ripristino.
- Resistenze corazzate.
- Corpo riscaldante rimovibile e micro di sicurezza.
- Protezione antiurto su resistenze facilmente smontabile.
- Posizione di sgocciolo per cestello.
- Coperchio in dotazione.
- Rubinetto opzionale.

- *In stainless steel.*
- *Reinforced basket.*
- *Thermostat and safety cut-off probe and reset button.*
- *Protected resistances.*
- *Removable heating body and safety switch.*
- *Shockproof protection on resistances easily disassembled.*
- *Position of basket drip.*
- *Lid supplied.*
- *Tap optional.*



ELDORADO 5



ELDORADO 5X2



ELDORADO 8 R



ELDORADO 8X2



1. Protezione antiurto resistenze
Shockproof protection for resistances



2. Posizione di sgocciolo
Position of drip



3. Pratico cestello da maneggiare
Easy to handle basket



4. (A) Bulbo termostato
(B) Pulsante di ripristino cut-off
(A) Thermostat bulb (B) Cut-off reset button

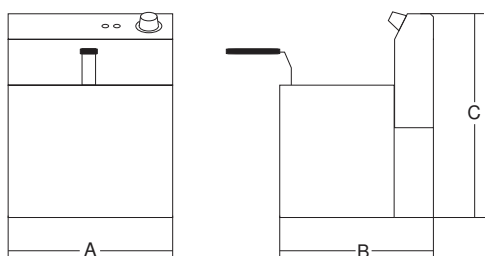

5. Facile da smontare e pulire
Easy to disassemble and clean

	Potenza Power Spannung Puissance	Alimentazione Power source Betriebsspannung Alimentation	Capacità vasca Tank capacity Becken-Kapazität Capacité cuve	Dimensioni cestello Basket dimensions Korbabmessungen Dimensionen du panier	A	B	C	Peso netto Net weight Nettogewicht Poids net	Dimensioni imballo Shipping Verpack-abmessungen Dim. emballage	Peso lordo Gross weight Brutogewicht Poids brut
	watt		lt	mm	mm	mm	mm	kg	mm	kg
Eldorado 5	2.700	230V/50Hz	min. 1,8 / max. 3,2	220x120 h.100	180	420	360	6	260x590x450	7
Eldorado 5x2	2.700+2.700	230V/50Hz	min. 1,8 / max. 3,2	220x120 h.100 (x2)	360	420	360	12	720x540x480	13
Eldorado 5+ 8	2.700+3.300	230V/50Hz	5 - min. 1,8/max. 3,2 8 - min. 3/max. 5	220x120 h.100 230x205 h.100	450	420	360	13	720x540x480	14
Eldorado 8	3.300	230V/50Hz	min. 3 / max. 5	230x205 h.100	270	420	360	7	570x320x420	8
Eldorado 8x2	3.300+3.300	230-400V/50Hz	min. 3 / max. 5	230x205 h.100 (x2)	530	420	360	14	720x540x480	15
Eldorado 8 R	3.300	230V/50Hz	min. 3 / max. 5	230x205 h.100	270	420	360	7,5	570x320x420	8,5
Eldorado 8x2 R	3.300+3.300	230 V/50Hz	min. 3 / max. 5	230x205 h.100 (x2)	530	420	360	15	720x540x480	16
Eldorado 10 R	6.000	400V/50Hz + N	min. 3,8 / max. 6	250x240 h.100	270	460	360	9	720x540x480	10
Eldorado 10x2 R	6.000+6.000	400V/50Hz + N	min. 3,8 / max. 6	250x240 h.100 (x2)	520	460	360	18	720x540x480	20

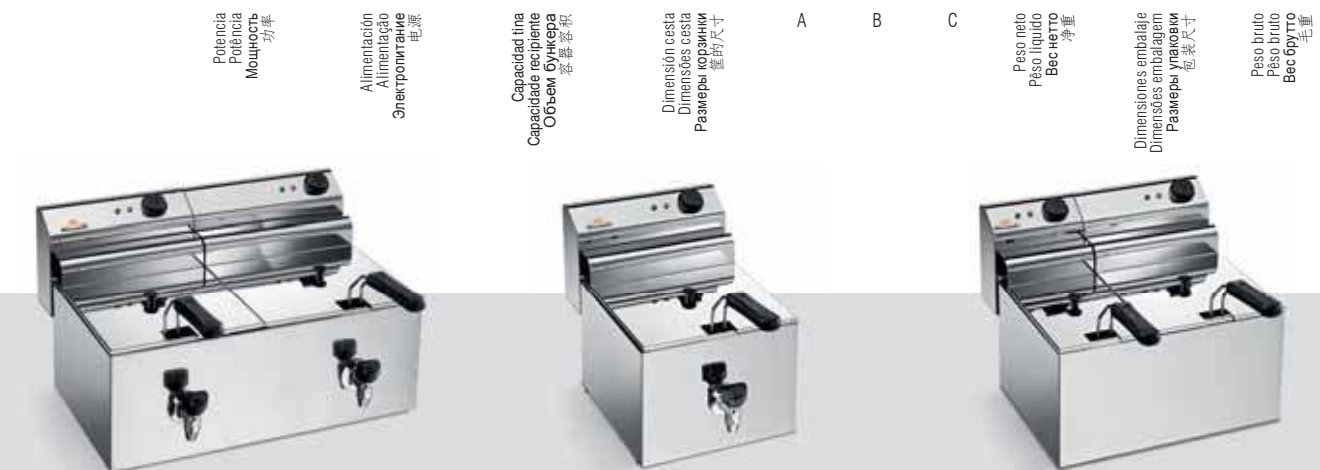

ELDORADO 10X2 R

ELDORADO 10 R

ELDORADO 5+ 8



PASTÌ

cuocipasta pasta cookers

- Struttura e vasca in acciaio inox.
- Cestelli microforati in acciaio inox con pratica impugnatura.
- Speciali resistenze corazzate antiruggine.
- Termostato di controllo.
- Protezione termica di sicurezza.
- Rubinetto carico/scarico acqua di serie.

Opzione

- Cestello maxi per Pasti 8

- Structure and tank in stainless steel
- Micro-drilled basket in stainless steel with handy grip.
- Special armored rust-proof heaters
- Control thermal switch
- Safety heat guard.
- Standard feature: inlet/outlet water faucet

Optional

- Extra-large basket for Pasti 8



PASTÌ 10

PASTÌ 8



PASTÌ 8



1. Cestello maxi:
di serie per Pasti 10 / opzionale per Pasti 8
Maxi basket:
standard for Pasti 10 / optional for Pasti 8

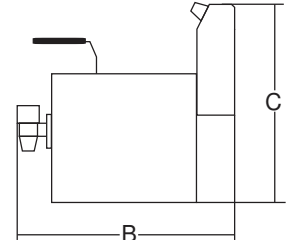
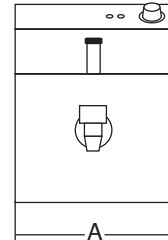

	Potenza Power Spannung Puissance	Alimentazione Power source Betriebsspannung Alimentation	Capacità vasca Bowl capacity Becken/Kapazität Capacité cuve	Dimensioni cestello Basket dimensions Korbabmessungen Dimensions du panier	A	B	C	Peso netto Net weight Nettogewicht Poids net	Dimensioni imballo Shipping Verpack, abmessungen Dim. emballage	Peso lordo Gross weight Bruttogewicht Poids brut
	watt		lt	mm	mm	mm	mm	kg	mm	kg
Pasti 8	3.000	230V/50Hz	6	100x120 h.130 (x4)	270	420	360	8,5	670x450x480	10
Pasti 10	6.000	380V/50Hz	8	95x220 h.130 (x3)	270	525	360	9,5	670x450x480	11

	Potencia Potência Мощность 功率	Alimentación Alimentação Электроснабжение 電源	Capacidad tina Capacidade recipiente Объем бункера 容量各款	Dimensioni cesta Dimensões cesta Размеры корзины 籃的尺寸	A	B	C	Peso neto Peso líquido Вес нетто 淨重	Dimensiones embalaje Dimensões embalagem Размеры упаковки 包裝尺寸	Peso bruto Peso bruto Вес брутто 毛重
--	--	---	--	--	---	---	---	--	---	--



PASTÌ 10



FORCELLA 20-35-50



impastatrici pizza dough mixers



Impastatrici a forcella ideali per la lavorazione di impasti per pane, pizza, piadine romagnole o di pasta fresca per tagliatelle e ravioli.

- Vasca in acciaio inox.
- Ampio coperchio in materiale antiurto trasparente
- Forcella in acciaio, attentamente studiata per ottimizzare l'impasto
- Trasmissione del moto tramite due motoriduttori ad ingranaggi.
- Disponibile anche in due velocità.

Fork dough mixers that are perfect to mix dough for bread, pizza, piadina pancakes, or fresh pasta for tagliatelle noodles and stuffed ravioli.

- Tank in stainless steel.
- Wide lid in transparent, collision-proof material
- Steel fork carefully studied to improve the dough product.
- Drive transmission provided by two reduction gears.
- Is also available in two speed versions.

	Potenza Power Spannung Puissance	Alimentazione Power source Betriebsspannung Alimentation	Capacità vasca Tank capacity Becken kapazität Cuve capacité	Capacità impasto Dough capacity Teig Kapazität Capacité pâte	Dimensioni ingombro Overall dimensions Außenabmessungen Dimensions extérieures	Peso netto Net weight Nettogewicht Pois net	Dimensioni imballo Shipping Verpack abmessungen Dim. emballage	Peso lordo Gross weight Bruttogewicht Poids brut
	kw		lt	kg	mm	Kg	mm	kg
Forcella 20	0,55	230-400V/50Hz	27	20	560x890 h.680	100	670x1020x880	116
Forcella 20 2V	0,55	400V/50Hz	27	20	560x890 h.680	100	670x1020x880	116
Forcella 35	0,75	230-400V/50Hz	39	35	600x930 h.680	104	670x1020x880	120
Forcella 35 2V	0,75	400V/50Hz	39	35	600x930 h.680	104	670x1020x880	120
Forcella 50 2V	1,00	400V/50Hz	67	50	680x1100 h.770	151	880x1120x960	175

Potencia
Potência
Мощность
功率

Alimentación
Alimentação
Энергопитание
電源

Capacidad lina
Capacidade recipiente
Объем емкости
容量

Capacidad masa
Capacidade da massa de pão
Тесто количество
面团容量

Dimensiones generales
Dimensões globais
Габариты
整机尺寸

Peso netto
Peso líquido
Вес нетто
净重

Dimensiones embalaje
Dimensões embalagem
Размеры упаковки
包装尺寸

Peso bruto
Peso bruto
Вес брутто
毛重



SP 310 - 420

stendipizza rolling machine



- Stendipizza pratici e di semplice utilizzo, ideali per stendere i dischi di pasta per la preparazione di pizze, focacce, pane, ecc.
- La lavorazione si svolge a freddo per non alterare le proprietà della pasta, lo spessore e il diametro dei dischi si possono facilmente regolare in base alle singole esigenze dell'utilizzatore.
- Costruzione in acciaio inox AISI 430.
- Raschiatori rullo inferiore facilmente smontabili per pulizia.
- Comandi IP 54 con NVR.
- Pedaliera di serie per la SP 420 RP e opzionale per tutti gli altri modelli.
- RP: Rulli paralleli

- *Practical and easy-to-use pizza roller, ideal for rolling out circles of dough to prepare pizza, focaccia, bread, etc.*
- *It operates without heat to avoid altering the properties of the dough. The thickness and diameter of the rolled out circles can be easily adjusted based on the user's needs.*
- *Made of AISI 430 stainless steel.*
- *Lower roller scrapers are easily removable for cleaning.*
- *IP 54 controls with NVR.*
- *Pedal standard for SP 420 RP and optional for all other models.*
- *RP: Parallel Rollers.*



SP 420/2



SP 310/1



SP 310/2



SP 420 RP



1. SP 310/1 predisposta per essere appesa a muro
SP 310/1: wall-mounted unit ready



2. Pedaliera di serie per la SP 420 RP e opzionale per tutti gli altri modelli.
Pedal standard for SP 420 RP and optional for all other models.

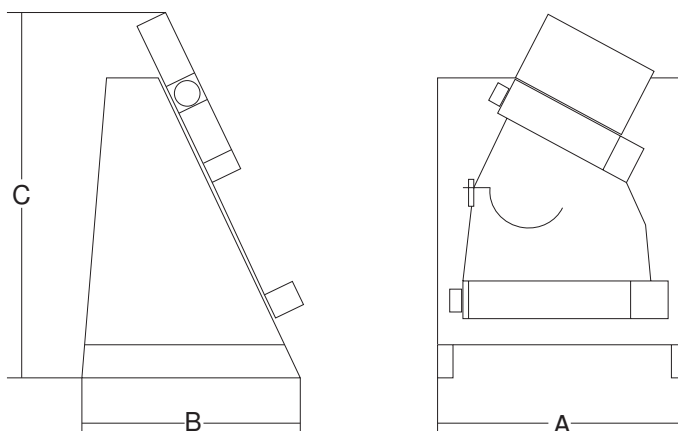

	Potenza Power Spannung Puissance	Alimentazione Power source Betriebsspannung Alimentation	Peso pasta Dough weight Gewicht d. Teiges Poids pâte	Diámetro pizza Pizza diameter Pizza Durchmesser Diámetro pizza	A	B	C	Peso netto Net weight Nettogewicht Poids net	Dimensioni imballo Shipping Verpack. abmessungen Dim. emballage	Peso lordo Gross weight Bruttogewicht Poids brut
	watt/HP		gr	ø mm	mm	mm	mm	Kg	mm	kg
SP 310/1	250/0,33	230-400V/50Hz	80/210	140/300	480	355	430	18	750x400x510	20
SP 310/2	250/0,33	230-400V/50Hz	80/210	140/300	440	380	615	25	750x400x510	27
SP 420/2	250/0,33	230-400V/50Hz	210/700	260/400	540	410	720	37	810x475x625	39,5
SP 420 RP	250/0,33	230-400V/50Hz	220/900	260/400	540	410	680	38	810x475x625	40,5

Potencia
Potência
Мощность
功率

Alimentación
Alimentação
Электроснабжение
電源

Peso de la masa
Peso da massa
Масса теста
面团的重

Diámetro de la pizza
Diámetro da pizza
Диаметр пиццы
直径比薩餅

A

B

C

Peso neto
Peso líquido
Вес нетто
淨重

Dimensiones embalaje
Dimensões embalagem
Размеры упаковки
包裝尺寸

Peso bruto
Peso bruto
Вес брутто
毛重



MINICOOKER - MYCOOK

frullatore termico semiprofessionale semi-professional thermal blender

- Frullatore termico semiprofessionale.
- Pratico ed irrinunciabile aiuto in cucina.
- Potente motore separato dalla zona cottura.
- Riscaldamento ad induzione che dimezza i tempi di messa in temperatura.
- Minicooker dotato di bilancia da 5 Kg con tara.
- Variatore velocità.
- Potenziometro per cotture fino a 120°.
- Pratica vasca in acciaio inox da 2 Lt.
- Mozzo coltelli a smontaggio rapido per una facile pulizia.
- Coperchio con chiusura di sicurezza.
- Dotato di spatola, farfalla mescolatrice e cestello forato.
- Tappo aggiunta ingredienti con dosatore.
- Programma soffritti.
- Set per cottura a vapore opzionale.

- *Semi-professional thermal blender.*
- *Practical, must-have kitchen aid.*
- *Powerful motor separated from the cooking zone.*
- *Induction heating which halves the time required to reach desired temperature.*
- *Minicooker supplied with 5 kg scales with tare.*
- *Speed changer.*
- *Potentiometer for cooking to 120°.*
- *Practical 2 L stainless steel bowl.*
- *Knife hub quick to dismantle for easy cleaning.*
- *Lid with safety closure.*
- *Spatula, butterfly mixer and perforated basket supplied.*
- *Add ingredients cap with measuring device.*
- *Sautéed vegetable program.*
- *Steam cooking set optional.*

MINICOOKER

1. Applicazione opzionale Steamer
Steamer cooking set optional

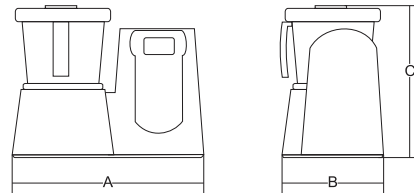

	Potenza Power Spannung Puissance	Alimentazione Power source Betriebsspannung Alimentation	Potenza induzione Induction power Induktion Macht Puissance de induction	Livelli velocità Speed levels Geschwindigkeitstufen Niveaux de vitesse	Temperatura Temperature Temperatur	Capacità vasca Bowl capacity Bekken Kapazität Capacité cuve	A	B	C	Peso netto Net weight Nettogewicht Poids net	Dimensioni imballo Shipping Verpack. abmessungen Dim. emballage	Peso lordo Gross weight Bruttogewicht Poids brut
	watt		watt	n.	°C	lt.	mm	mm	mm	kg	mm	kg
Minicooker	600	230V/50 Hz	1000	10	120	2	360	300	290	10	400x370x540	11
Mycook	800	230V/50 Hz	1000	10	120	2	360	300	290	9	400x370x540	10

Potencia Potência Мощность	Alimentación Alimentação Электропитание	Potencia de inducción Potência de indução Мощность индукции	Niveles de velocidad Níveis de velocidade Скорость уровней	Temperatura Temperatura Температура	Capacidad línea Capacidade recipiente Объем бункера	A	B	C	Peso neto Peso líquido Вес нетто	Dimensiones embalaje Dimensões embalagem Размеры упаковки	Peso bruto Peso bruto Вес брутто
功率	电源	感应功率	速度水平	温度	容量				净重	包装尺寸	毛重



MYCOOK





KIRO

frullatore ad immersione hand-held mixer

Frullatore ad immersione professionale dalla forma semplice e robusta.

- Maneggevole e pratico
- Ideale per piccole lavorazioni
- Impugnatura ergonomica
- Asta separabile per una accurata pulizia.
- Solo per uso discontinuo

- Handy and easy to use
- Ideal for little quick operations
- Ergonomic handle
- Removable shaft for easy cleaning
- Light-duty operations only

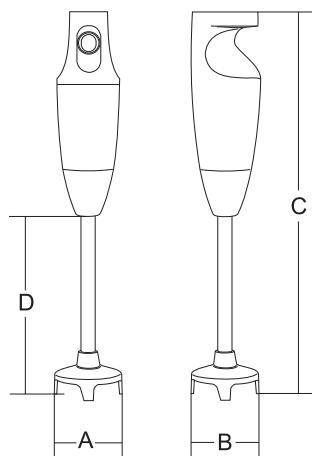

	Potenza Power Spannung Puissance	Alimentazione Power source Betriebsspannung Alimentation	Giri coltelli Knives revolutions Umdrehungen messers Tours couteaux	Capacità di lavoro Working capacity Arbeitsfähigkeit Capacité de travail	A	B	C	D	Peso netto Net weight Nettogewicht Poids net	Dimensioni imballo Shipping Verpack. abmessungen Dim. emballage	Peso lordo Gross weight Bruttogewicht Poids brut
	watt/HP	230V/50Hz	r.p.m.	lt	mm	mm	mm	mm	Kg	mm	kg
KIRO	175/0,25	230V/50Hz	14.500	20	72	72	392	190	1	85x83x400	1,15
	Potencia Potência Мощность 功率	Alimentación Alimentação 电源	Vueltas cuchillos Giros lâminas Скорость вращения 刀片转速	Capacidad de trabajo Capacidade de trabalho 工作能力	A	B	C	D	Peso netto Peso líquido Вес нетто 净重	Dimensiones embalaje Dimensões embalagem Размеры упаковки 包装尺寸	Peso bruto Peso bruto Вес брутто 毛重



EKTO R 37

estrattore slow Juicer

Estrattore a bassa velocità per l'estrazione di succhi a freddo da frutta e verdura.

- Speciale tramoggia di introduzione che agevola il carico dei pezzi più grossi.
- Coclea ad alta efficienza.
- Tappo salvagoccia.
- Pratico e veloce smontaggio delle parti interessate alla lavorazione.
- Pestello per agevolare l'avanzamento dell'alimento inserito.
- Spazzola per la pulizia.
- Vaschetta per gli scarti e una per il succo, di serie.
- Dotato di 2 cestelli con diversa foratura.
- Potente motore asincrono ventilato con riduzione ad ingranaggi.

Low-speed juicer extractor for fruits and vegetables

- *Special introduction hopper for easy loading of larger pieces.*
- *High efficiency screw propeller.*
- *Drip cap.*
- *Quick and easy disassembly of the parts used for processing.*
- *Pestle for easy introduction of the products.*
- *Cleaning brush.*
- *Equipped with 2 trays: one for juice and one for waste.*
- *Equipped with 2 different drilling strainers.*
- *High efficiency asynchronous ventilated motor.*



1. Tappo salvagoccia
Drip cap



2. Vaschetta per gli scarti
Tray for waste



3. Speciale tramoggia di introduzione che agevola il carico dei pezzi più grossi.
Special introduction hopper for easy loading of larger pieces.



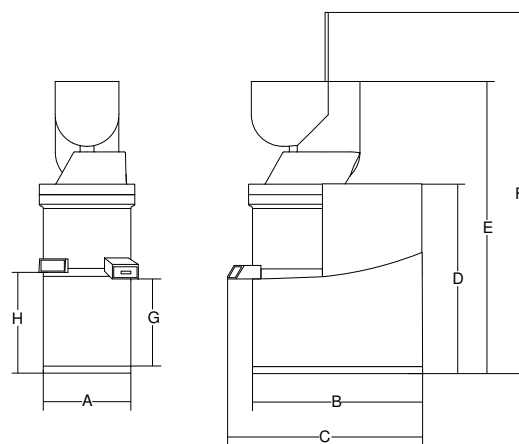

	Potenza Power Spannung Puissance	Alimentazione Power source Betriebsspannung Alimentation	Giri Revolutions Umdrehungen Tours	Dimensioni tramoggia Hopper dimensions Ölming Größe Dimensions douche	A	B	C	D	E	F	G	H	Peso netto Net weight Nettogewicht Poids net	Dimensioni imballo Shipping Verpack abmessungen Dim. emballage	Peso lordo Gross weight Bruttogewicht Poids brut
	watt/HP		r.p.m.	mm	mm	mm	mm	mm	mm	mm	mm	mm	Kg	mm	kg
Ektor 37	250/0,34	230V/50Hz	37	140x80	145	220	240	342	450	530	160	166	6,7	370x290x340	8
	Potencia Potência Мощность 功率	Alimentación Alimentação Электропитание 电源	Vueltas Giros Обороты/мин 轉速	Dimensiones boca Dimensões bucal Горловины 料口尺寸	A	B	C	D	E	F	G	H	Peso netto Peso líquido Вес нетто 淨重	Dimensiones embalaje Dimensões embalagem Размеры упаковки 包裝尺寸	Peso bruto Peso bruto Вес брутто 毛重





SALENTO - SO AVE - COLLI O RIENTALI - MONFERRATO

cantinette wine cooler

- Porta reversibile con vetro temperato doppio, compresa di serratura con chiave.
- Ripiani estraibili in legno.
- Comandi digital touch.
- Regolazione termostato in °C o °F.
- Display e luce interna a led.
- Autosbrinamento.
- Filtro attivo al carbone.
- Ventilazione interna.
- Modelli Salento e Soave predisposti da semincasso.

- Reversible door with double tempered glass and key lock.
- Removable wood shelves.
- Digital touch controls.
- Thermostat adjustment in °C or °F.
- LED display and interior light.
- Auto-defrost.
- Active carbon filter.
- Interior fan.
- Salento and Soave models can be semi built-in.



SALENTO



SOAVE



COLLI ORIENTALI



MONFERRATO



SO AVE/ SALENTO



MONFERRATO



COLLI ORIENTALI



MONFERRATO



COLLI ORIENTALI / MONFERRATO

SOAVE / SALENTO

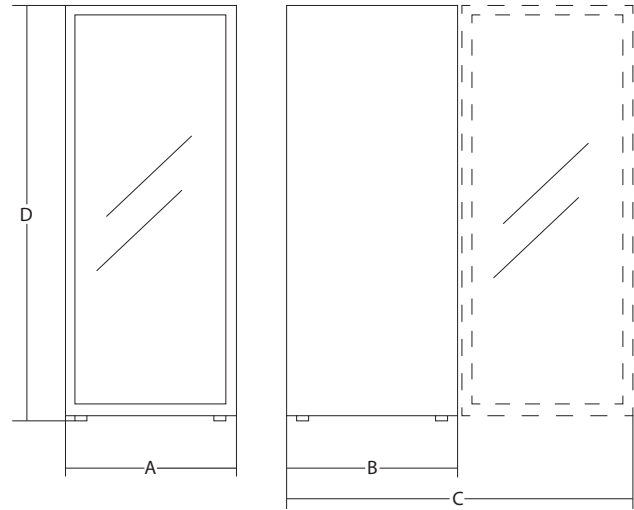
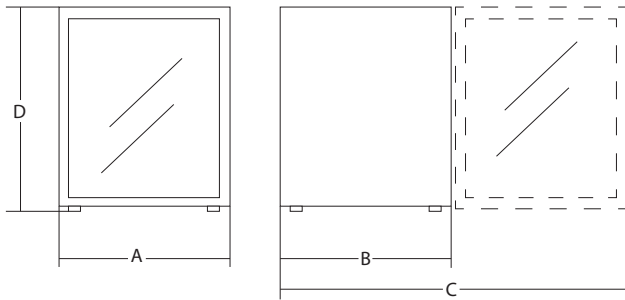

	Alimentazione Power source Netzspannung Alimentation	Potenza assorbita Required power Leistungsaufnahme Puissance absorbée	Termostato Thermostat Thermostat Thermostat	Zone refrigerate Refrigerated zone Kühlzone Zone réfrigérée	Capacità max bottiglie Max capacity bottles Max Kapazität Flaschen Max capacité bouteilles	Volume Volume Volumen Volume	A	B	C	D	Peso netto Net weight Nettogewicht Poids net	Dimensioni imballo Shipping Verpack. abmessungen Dim. emballage	Peso lordo Gross weight Brutto gewicht Poids brut
	watt	°C	n.	n.	lit.	mm	mm	mm	mm	kg	mm	kg	
Salento	230V/50Hz	120	5-22	1	51	150	595	575	1145	850	43	655x675x865	49
Soave	230V/50Hz	120	5-12 / 12-22	2	51	150	595	575	1145	850	43	655x675x865	49
Colli Orientali	230V/50Hz	150	5-12 / 12-22	2	96	270	595	590	1130	1640	75	655x620x1700	80
Monferrato	230V/50Hz	160	5-12 / 12-22	2	182	450	595	760	1380	1800	90	650x765x1830	95

Alimentación
Alimentação
Электроснабжение
電源

Potencia absorbida
Potência absorvida
Потребляемая мощность
需求功率

Termostato
Termostato
Термостат
恒温器

Zonas refrigeradas
Áreas refrigeradas
Охлаждаемые отсеки
冷藏区域

Capacidad máx de botellas
Capacidade máx de garrafas
Мак. вместимость бутылок
可藏瓶数

Volumen
Volume
Объем
体积

A B C D

Peso neto
Peso líquido
Вес нетто
净重

Dimensiones embalaje
Dimensões embalagem
Размеры упаковки
包装尺寸

Peso bruto
Peso bruto
Вес брутто
毛重



SALENTO

SOAVE

COLLI ORIENTALI

MONFERRATO

CARRELLI E TAVOLI INOX TROLLEY AND S/STEEL WORKING TABLE



Pianetta inox
S/Steel Platform Trolley
mm 900x600 h.900
capacity kg 300
cod. 75010000



Carrello servizio inox 2 piani
2 Shelves S/Steel Trolley
mm 855x535 h.930
capacity kg 80 (totale/total)
cod. 75000200



Carrello servizio inox 3 piani
3 Shelves S/Steel Trolley
mm 855x535 h.930
capacity kg 120 (totale/total)
cod. 75000300



Carrello con ripiano GN 1/1
Tray rack for GN 1/1 trays
mm 385x550 h.870
capacity n.7 teglie/trays
cod. 75050700



Carrello porta teglie GN 1/1
Trolley for GN 1/1 trays
mm 385x550 h.1735
capacity n.15 teglie/trays
cod. 75001500



Carrello porta teglie GN 1/1
Trolley for GN 1/1 trays
mm 740x550 h.1735
capacity n.15x2 teglie/trays
cod. 75003000



Carrello con ripiano 60x40
Tray rack for trays 60x40
mm 470x620 h.915
capacity n.7 teglie/trays
cod. 75056407



Carrello porta teglie 60x40
Trolley for trays 60x40
capacity n.15 teglie/trays
cod. 75056415



Tavolo inox
S/steel working table
mm 1600x700 h.860
capacity kg 300
cod. 75061670



Tavolo inox con alzatina
S/steel working table with backguard
mm 1600x700 h.950
capacity kg 300
cod. 75061672



Scaffalatura inox 4 ripiani
4 levels stainless steel shelves
mm 1200x500 h.1550
capacity kg 400
cod. 75010400



SAR-C 447 E

vetrinetta frigo refrigerated glass case



- Vetrinetta frigo dal design moderno studiata per accogliere in uno spazio ridotto grandi quantitativi di prodotti.
- Caratterizzata da spondine laterali trasparenti, porta posteriore per l'aggiunta e sistemazione del prodotto, regolazione della temperatura dal retro e termometro interno visibile.
- Pratica e facile da gestire, è indicato per supermercati, alimentari, ristoranti, palestre, ecc.

- *The refrigerated glass case has a modern design and has been studied to fit a large quantity of products into a small space.*
- *It is characterized by transparent side panels, a back door for adding or moving products around, temperature adjustment from the back and a visible internal thermometer.*
- *Practical and easy to manage, it is ideal for supermarkets, food stores, restaurants, gyms, etc.*



Capacità prodotto:

- pz. 97 bottiglie (h. 122 x ø 45 mm)
- pz. 74 lattine (250 ml - h. 133 x ø 53 mm)
- pz. 48 lattine (350 ml - h. 122 x ø 66 mm)
- pz. 30 bottiglie (500 ml - h. 209 x ø 68,5 mm)

Product Capacity:

- *pz. 97 bottles (h. 122 x ø 45 mm)*
- *pz. 74 cans (250 ml - h. 133 x ø 53 mm)*
- *pz. 48 cans (350 ml - h. 122 x ø 66 mm)*
- *pz. 30 bottles (500 ml - h. 209 x ø 68,5 mm)*

Potenza assorbita
Required power
Leistungsaufnahme
Puissance absorbée

Alimentazione
Power source
Netzspannung
Alimentation

Gas
Gas
Газ
Gas

Temperatura interna
Inner temperature
Innen Temperatur
Température intérieure

Volumen
Volume
Volumen
Volumer

Dimensioni interne
Inner dimensions
Gebrauchsmessungen
Dimensions intérieures

Dimensioni ingombro
Overall dimensions
Außenabmessungen
Dimensions extérieures

Peso netto
Net weight
Nettogewicht
Poids net

Dimensioni imballo
Shipping
Verpack. abmessungen
Dim. emballage

Peso lordo
Gross weight
Bruttogewicht
Poids brut

	Watt	230V/50Hz	HFC 134a	°C	lt	mm	mm	Kg	mm	Kg
SAR - C 447 E	260	230V/50Hz	HFC 134a	5 - 20	40	430x490x715	490x490x715	31	550x550x80	34

Potencia
Potência
Мощность
功率

Alimentación
Alimentação
Электропитание
電源

Gas
Gas
Газ
氣的

Temperatura interior
Temperatura interna
Внутренняя температура
内部温度

Volumen
Volume
Объем
体积

Dimensiones internas
Dimensões internas
Внутренние размеры
内部尺寸

Dimensiones externas
Dimensões externas
Габариты
臺外尺寸

Peso neto
Peso líquido
Вес нетто
淨重

Dimensiones embalaje
Dimensões embalagem
Размеры упаковки
包裝尺寸

Peso bruto
Peso bruto
Вес брутто
毛重



WF 431 ABP

lavatrice washing machine



- PowerFoam
- Eco Cold Wash Cycle:
Use cold water and foam to clean clothes just as effectively as a conventional warm water cycle and at 65% less energy.
- VRT™ - Vibration Reduction Technology
- Quiet Operation.
- Stainless steel Diamond Drum™ Design
- 13 Wash Cycles and 10 Options
- 1.300 RPM Maximum Spin Speed
- Direct Drive Motor
- Internal Water Heater (Sanitize Wash Cycle)
- Water Temperature Sensor
- Energy Star® Qualified
- Washer Drum Light
- End Of Cycle Signal
- Delay Start - up to 24 hours
- Automatic Dispensers:
Pre-Wash, Main Wash, Bleach, Fabric Softener
- Optional Pedestals or Stacking Kit Available
- Graphic LED display
- 5 Temperature Settings:
Extra Hot/Cold, Hot/Cold/, Warm/Warm, Warm/Cold, Cold/Cold
- 5 Spin Speeds:
Extra High, High, Medium, Low, No spin
- Duration of the standard programs:
Cotton 60 °C at full load: 216 min
Cotton 60 °C for partial load: 196 min
Cotton 40 °C with partial load: 166 min.
- Energy Efficiency: A++
- Spin efficiency class: B

- PowerFoam
- Ciclo di lavaggio Eco Cold:
Utilizza acqua fredda e schiuma con la stessa efficacia di un normale ciclo con acqua calda, ma con il 65% di energia in meno.
- VRT™ - Vibration Reduction Technology
- Estrema silenziosità di funzionamento
- Cestello in acciaio inox con Diamond Drum™ Design
- 13 cicli di lavaggio con 10 opzioni
- Velocità massima di rotazione: 1.300 RPM
- Motore a presa diretta
- Riscaldatore interno dell'acqua (ciclo di lavaggio e sterilizzazione)
- Indicatore temperatura acqua
- Qualificato Energy Star®
- Illuminazione cestello
- Segnale di fine ciclo
- Accensione differita - fino a 24h
- Erogatore automatico: pre-lavaggio, lavaggio principale, candeggio, lavaggio con ammorbidente
- Base e kit per sovrapposizione disponibili come optional
- LED display
- 5 livelli di temperatura:
Molto calda/Fredda, Calda/Fredda, Calda/Calda, Calda/Fredda, Fredda/Fredda
- 5 velocità centrifuga:
Molto alta, Alta, Media, Bassa, No Centrifuga
- Durata programmi standard:
Cotone 60°C a pieno carico: 216 min
Cotone 60°C a carico parziale: 196 min
Cotone 40°C a carico parziale: 166 min.
- Classe di efficienza energetica: A++
- Classe di efficienza centrifuga: B



1. Cestello in acciaio inox
Diamond Drum™
Stainless steel Diamond Drum™

	Potenza assorbita Required power Leistungsaufnahme Puissance absorbée	Alimentazione Power source Netzspannung Alimentation	Pressione acqua Water pressure Wasserdruck Pression de l'eau	Velocità max centrifuga Max spin speed Max Schleuderrichtzahl Vitesse d'essorage max	Capacità Capacity Kapazität Capacité	Dimensioni cestello Drum dimensions Trommel Abmessungen dimensions tambour	Dimensioni ingombro Overall dimensions Aufgabenmessungen Dimensions extérieures	Peso netto Net weight Nettogewicht Poids net	Dimensioni imballo Shipping Verpack. abmessungen Dim. emballage	Peso lordo Gross weight Bruttogewicht Poids brut
	Watt		kPa	rpm	Kg	mm	mm	Kg	mm	Kg
WF 431 ABP	2.000-2.400	230V/50Hz	137-800	1.200	14	450x570	690x820 h.980	99	760x840x1050	102
	Potencia absorbida Potência absorvida 需求功率 Потребляемая мощность	Alimentación Alimentação Электроснабжение 电源	Presión del agua Pressão de água Давление воды 水压	Velocidad máx de centrifugado Velocidade máx de centrifugação Максимальная скорость отжима 最大脱水速度	Capacidade Capacidade Вместимость 容積	Dimensiones cesta Dimensões da cesta Размеры барабана 滚筒尺寸	Dimensiones externas Dimensões externas Габариты 整机尺寸	Peso neto Peso líquido Вес нетто 净重	Dimensiones embalaje Dimensões embalagem Размеры упаковки 包装尺寸	Peso bruto Peso bruto Вес брутто 毛重



DV 431 AEP



asciugatrice dryer



- Asciugatura a vapore (Steam Drying Technology)
- 13 cicli di asciugatura con 8 opzioni
- Cestello in acciaio inox
- Porta con finestra trasparente
- Illuminazione cestello
- Funzione MyCycle
- Indicatore controllo filtro
- Indicazione tempo rimanente
- Base e kit per sovrapposizione disponibili come optional
- Certificata Woolmark per un trattamento più delicato ed anti infeltrimento della lana
- Steam Refresh: l'emissione di vapore riduce le pieghe, rimuove gli odori e ridà tono agli indumenti.
- Sensor Dry: un sensore rileva il grado di umidità nel carico e regola il tempo di asciugatura per risparmiare tempo e denaro.
- Funzione anti pieghe: alla fine del ciclo rigira gli indumenti a intermittenza per prevenire pieghe.
- Mixed Load Bell: avvisa che alcuni indumenti possono essere rimossi. I capi che richiedono maggiore tempo per asciugare rimangono quindi nella macchina per completare, più in fretta, l'asciugatura.
- 5 livelli di temperatura
- 5 livelli di asciugatura
- 5 livelli di segnale acustico

- Steam Drying Technology
- 13 Pre-set Dry Cycles and 8 Options
- Stainless Steel Drum
- Reversible See-Through Door
- Dryer Drum Light
- My Cycle
- Remaining Time Display
- Optional Pedestals or Stacking Kit Available
- Woolmark Certified for more gentle handling and anti-shrinking
- Steam Refresh: infuses clothes with steam to reduce wrinkles, remove odours, and refresh clothing
- Sensor Dry: detects the moisture level in the load and adjusts the drying time to save time and money
- Wrinkle Prevent Option: intermittently tumbles clothes at the end of the drying cycle to help prevent wrinkles from setting in.
- Mixed Load Bell: notifies you that certain garments can be taken out early while letting others continue to dry. Heavier and tougher clothes that require extra drying time then stay in the machine to be dried further, and quicker.
- 5 Temperature Settings
- 5 Dry Levels
- 5 Signal Sound Levels



1. Cestello in acciaio inox
Stainless steel drum

Potenza assorbita senza calore
Power consumption no heat
Aufgenommenen Leistung ohne Wärme
Puissance absorbée sans chauffage

Potenza assorbita con calore
Power consumption heating
Aufgenommenen Leistung mit Wärme
Puissance absorbée avec chauffage

Potenza riscaldamento
Heater rating
Leistung Erwärmung
Puissance de chauffage

Alimentazione
Power source
Netzspannung
Alimentation

Velocità max centrifuga
Max spin speed
Max Schleuderdrehzahl
Vitesse d'essorage max

Capacità
Capacity
Kapazität
Capacité

Dimensioni cestello
Drum dimensions
Trommel Abmessungen
dimensions tambour

Dimensioni ingombro
Overall dimensions
Aufgabenmessungen
Dimensions extérieures

Peso netto
Net weight
Nettogewicht
Poids net

Dimensioni imballo
Shipping
Verpack abmessungen
Dim. emballage

Peso lordo
Gross weight
Bruttogewicht
Poids brut

	Watt	Watt	Watt		rpm	Kg	mm	mm	Kg	mm	Kg
DV 431 AEP	200	4.900	4.700	230V/50Hz	1.200	10	640x670	690x790 h.990	57,2	760x840x1080	61

Potencia absorbida sin calor
Potência absorbida sem calor
Потребляемая мощность без подогревания
不带加热的能耗

Potencia absorbida con el calor
Potência absorbida com o calor
Потребляемая мощность с подогреванием
带加热的能耗

Potencia de calefacción
Potência calorífica
Мощность подогревания
加热器功率

Alimentación
Alimentação
Электропитание
电源

Velocidad max de centrifugado
Velocidade max de centrifugação
Максимальная скорость отжима
最大脱水速度

Capacidad
Capacidade
Вместимость
容積

Dimensiones cesta
Dimensões da cesta
Размеры барабана
滚筒尺寸

Dimensiones externas
Dimensões externas
Габариты
整机尺寸

Peso neto
Peso líquido
Вес нетто
净重

Dimensiones embalaje
Dimensões embalagem
Размеры упаковки
包装尺寸

Peso bruto
Peso bruto
Вес брутто
毛重



Sirman S.p.a.
Viale dell'Industria 9/11
35010 Pieve di Curtarolo (PD) Italy
Tel. + 39 049 9698666 - Fax + 39 049 9698688
www.sirman.com - info@sirman.com

© 2016 Copyright Sirman S.p.a.

I diritti delle immagini appartengono a Sirman.

La riproduzione anche parziale delle foto e dei testi è vietata.

I dati tecnici e le caratteristiche possono subire variazioni senza preavviso.

VER. 2016.2

Printed in Italy

Finito di stampare marzo 2016



www.sirman.com