

# MENUMASTER® Commercial



Model MXP5221TLT shown

15 times faster than conventional ovens.

## High Speed Combination Oven Menumaster® Commercial MXP5221TLT & MXP5223TLT

### Power Output

- Forced convection:
  - 2000 W
  - 95° - 270° C (200° - 520° F) temperature range
  - Forced convected air for enhanced toasting and browning
- Microwave:
  - 2200 W
  - Heats quickly, reduces cooking time
- Infra-red radiant:
  - 3000 W
  - Enhances toasting and browning



**Heavy Volume | Combination Cooking**  
This category of combination oven is ideal for...

**Application:**

- Theatres	- Pizzerias
- Convenience stores	- Hotel room service
- Satellite locations	- Campus dining
- Healthcare	- Snack bars
- Stadiums	

**Through put potential:**

- 12" frozen pizza, 20 per hour
- 6" toasted sub sandwiches, 80+ per hour
- Grilled fresh salmon, 20 per hour
- Crème brûlé, 10 per hour
- 1 lb. portions fresh shrimp, 30 portions per hour

**Location of oven(s):**

- Kitchen shelf
- Kitchen countertop, single or stacked
- Equipment stand, single or stacked

**Defrost:**

- Defrosts most frozen food products in microwave mode

### Cuts Costs

- No need for costly ventilation hood - catalytic converter filters grease and odors from the air. Integrated recirculating catalytic converter for ventless operation.
- Uses less energy than a conventional oven.
- Eliminates need for pre-cooking and holding.
- Uses standard metal trays, pans and screens.

### Simplifies Cooking

- Touch screen operation for consistent results.
- Transfer programming information via USB port, wi-fi or ethernet
- Controls are intuitive and simple to use.
- Stores up to 360 menu items.
- Four stage cooking option.
- 39 liter (1.38 cubic ft.) oven capacity.
- Door drops down below oven rack providing full access to oven interior.

### Easy to Use and Maintain

- Non-stick oven liners installed.
- Porcelain IR element cover enhances operator safety and simplifies maintenance
- Stainless steel exterior and interior.
- Infra-red elements tilt-up for cleaning.
- Two removable air filters protect oven components.
- ETL Listed.



Patents Pending

Part No. 20154330  
Updated 10/4/16  
Original Instructions



© 2016 ACP, Inc.  
Cedar Rapids, Iowa 52404

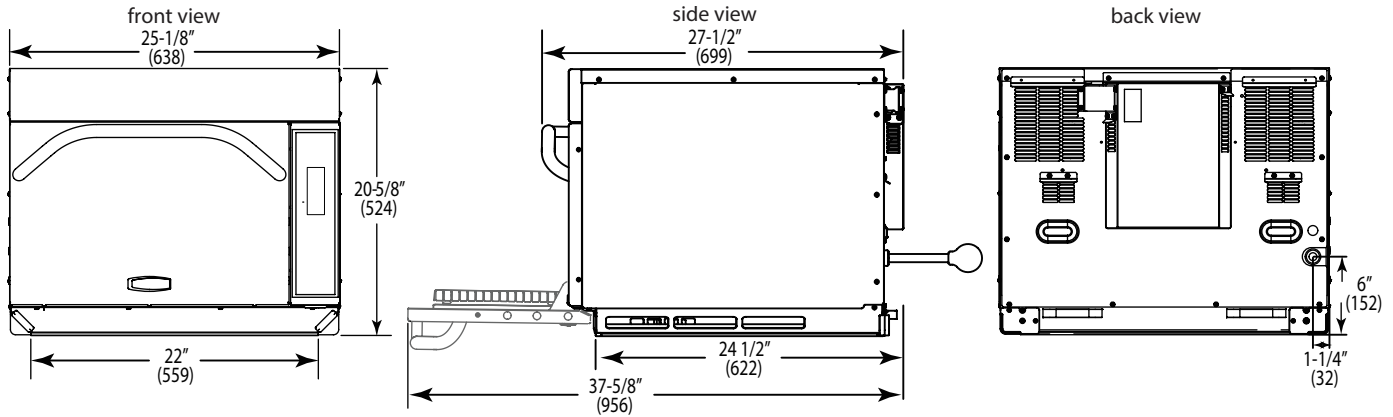



Not intended for built-in applications

Installation Clearances - Top: 51 (2"), Sides: 25 (1"), Back: None

Drawings available from KCL CADlog - techs@kclcad.com

Specification #:

Specifications	
Model	MXP5221TLT 728028422580 MXP5223TLT 728028422634
Cooking Power*	2000W 2200W 3000W
	Forced Convection Microwave Infra-red radiant
Configuration	Countertop
Menu Capacity	360 items
Power Levels	11
Max. Cooking Time	60:00
Program Menu	Multi-level menu capability
Defrost	Yes, microwave only, power level 2
Time Entry Option	Yes
Microwave Distribution	Double side oscillating antenna
Magnetrons	2
Display	Touch screen, color LCD
Stackable	Yes
Stage Cooking	Yes, 4
Door Opening	Pull down, ergonomic handle
USB Port	Yes
Temperature Range	95° - 270° C (200° - 520° F)
Air Filter	2 removable, with clean filter reminder
Fan Speed	0-100%
Rack	1 rack position, removable
Exterior Dimensions	H 518 (20 3/8") W 638 (25 1/8") D** 699 (27 1/2")
Cavity Dimensions	H 254 (10") W 406 (16") D 381 (15")
Door Depth	956 (37 5/8"), drop down door
Usable Cavity Space	39 liter (1.38 cubic ft.)
Exterior Finish	Stainless steel
Interior Finish	Stainless steel
Power Consumption	5800 W, 27.4 A
Power Output*	2200 W* Microwave
Power Source	MXP5221TLT 208 - 240 V, 50 Hz, 32 A single phase MXP5223TLT 400 V, 50 Hz, Wye, 16 A, 3 phase, 5 wire
MXP5221TLT Plug Configuration / Cord	IEC 309 1.5 m (5 ft.) 
MXP5223TLT Plug Configuration / Cord	IEC 309 2.4 m (8 ft.) 
Frequency	2450 MHz
Product Weight	68 kg (150 lbs.)
Ship weight (approx.)	79 kg (175 lbs.)
Shipping Carton Size	H 826 (32 1/2") W 717 (28 1/4") D 883 (34 3/4")

AIA File #:

**Specifications**

Oven shall combine three cooking modes: forced convection, microwave and infra-red radiant for high speed cooking. Icon operated control panel shall be programmable with the ability to program a maximum of 360 menu items and shall have multi-level menu capability. Programs shall be automatically updated using either Wi-Fi, ethernet or USB port. Display shall be a swipe touch screen, color LCD. There shall be 11 power levels, 4 cooking stages and defrost mode. Microwave output shall be 2200 watts and distributed from two magnetrons located on each side of the cavity. An automatic voltage sensor shall accommodate either 208 or 240 volts with no manual adjustment. Oven shall provide a temperature range from 95° - 270° C (200° - 520° F) in 5° increments. The convection fan shall distribute the heat throughout the cavity to further reduce cook times. Fan speed to be programmed from 0 to 100% for menu flexibility. The infra-red radiant shall have 3000 watt output and deliver heat from the bottom of the oven. This element shall be concealed with porcelain cover and hinged for easy cleaning of the oven floor. The oven cavity shall have a 39 liter (1.38 cubic ft.) capacity and use standard metal cookware. Maximum microwave cooking time shall be 60 minutes. Oven shall have non-stick oven liners installed. Oven shall have a stainless steel exterior and be stackable. Oven cavity shall be stainless steel construction with stainless oven door. Drop down door shall open below oven rack for full access to the cavity. The two side air filters shall be removable for easy cleaning and have a "clean filter" reminder feature. A removable, one position rack shall be included. Microwave oven shall comply with standards set by the U.S Department of Health and Human Services, ETL listed for safety and sanitation.

**Optional Accessories**

- Panini Press
- Pizza stone 14 3/8" (365mm) dia.
- Leg kit - set of four 4" (102mm) legs
- Non-stick baskets - set of two
  - 10" x 12" x 1" (254 x 305 x 25mm) size
  - 6" x 12" x 3/4" (152 x 305 x 19mm) size
- Stainless carts/equipment stands 24" (610) and 30" (762)
- Oven paddle

**Warranty**

Warranty Certificate for this product can be found by locating it on the ACP, Inc. website at:

[www.acpsolutions.com/warranty](http://www.acpsolutions.com/warranty)

Measurements are in millimeters

\* IEC 60705 Tested

\*\* Includes handle

